

U-Series Air Circuit Breakers



LV & MV Circuit Breakers

Leader of Technology

CONTENTS

04 Features • 12 Structure • 14 Ratings • 15 Protection Trip Relay (OCR) • 36 Accessories • 84 Circuit Diagrams
86 Dimensions • 104 Ordering Codes • 111 Technical Data • 122 Operating Conditions • 124 Ordering Sheet



U-Series Air Circuit Breakers

Hyundai Heavy Industries (HHI) ACB meets your demands for high breaking capacity, full line-up, and optimized panel size. Various accessories and connection methods realize user-friendly handling.



Features

| Full line-up |

- U-Series ACB maximize your choice and satisfaction with compact size and dual (UAN/UAS) model.

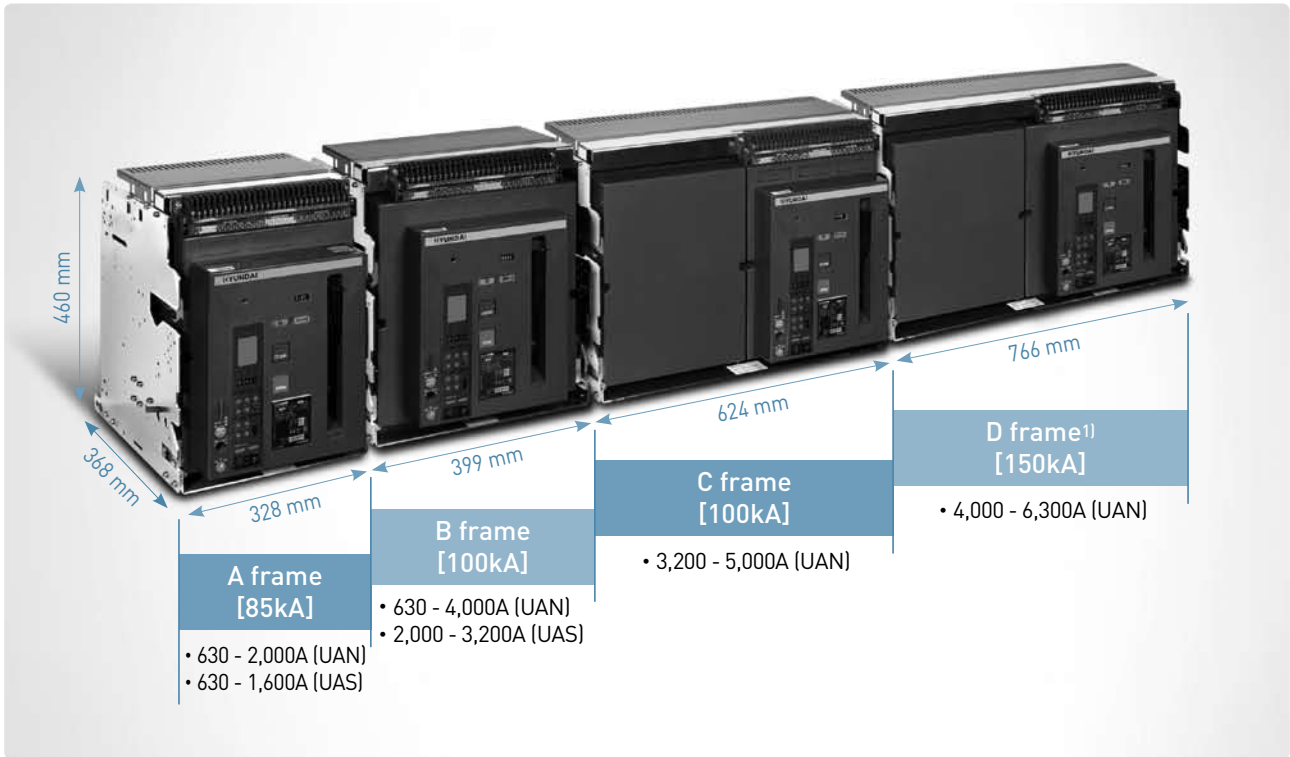

※ - Breaking capacity is at AC500V.

1) D frame will be available from 2015-1st half.

| Applications |

- U-Series ACB offering high breaking capacity and advanced protection trip relay is suitable to cover various applications including buildings, data centers, industrials and so on. U-Series ACB protects these facilities from harmonic frequency by 100 % capacity of N phase.



Buildings

- Multipurpose buildings
- Hospitals
- Commercial buildings
- Hotels



Data centers & Networks

- Broadcasting stations
- IT/Telecommunications



Industrials

- Steel/Metal
- Gas/Chemical
- Pulp/Paper



Electric power facilities

- Electric power stations
- Electric power substations
- Dispersed power generators
- Renewable energy facilities

| Compliance with standards |

■ Standard

- IEC 60947-1,2 International Electrotechnical Commission
- EN 60947-2 European Standard
- GB China National Standard (Guojia Biaozhun)
- GOST R 50030.2-99 9 Government Standard of Russia
- GOST R 50030.1-2000 Government Standard of Russia
- KS C 4620 Korean Standards Association

■ Approval

- ISO 18001, 14001, 9001
- KS/KOREA Korea Quality Certificate Standard Association
- CE Community European
- GOST-R/RUSSIA Government Standard of Russia
- CCC/CHINA China Compulsory Certification
- KR/KOREA Korean Register of Shipping
- GL/GERMANY Germanischer Lloyd
- LR/U.K Lloyd's Register of Shipping
- ABS/U.S.A American Bureau of Shipping
- BV/France Bureau Veritas
- NK/JAPAN Nippon Kaiji Kyokai
- DNV/NORWAY Det Norske Veritas
- RINA/ITALY Regiserio Italland Navale
- RS/RUSSIA Russian Maritime Register of Shipping

■ CB type test

- DEKRA Formerly KEMA Quality Registered
- KERI Korea Electrotechnology Research Institute

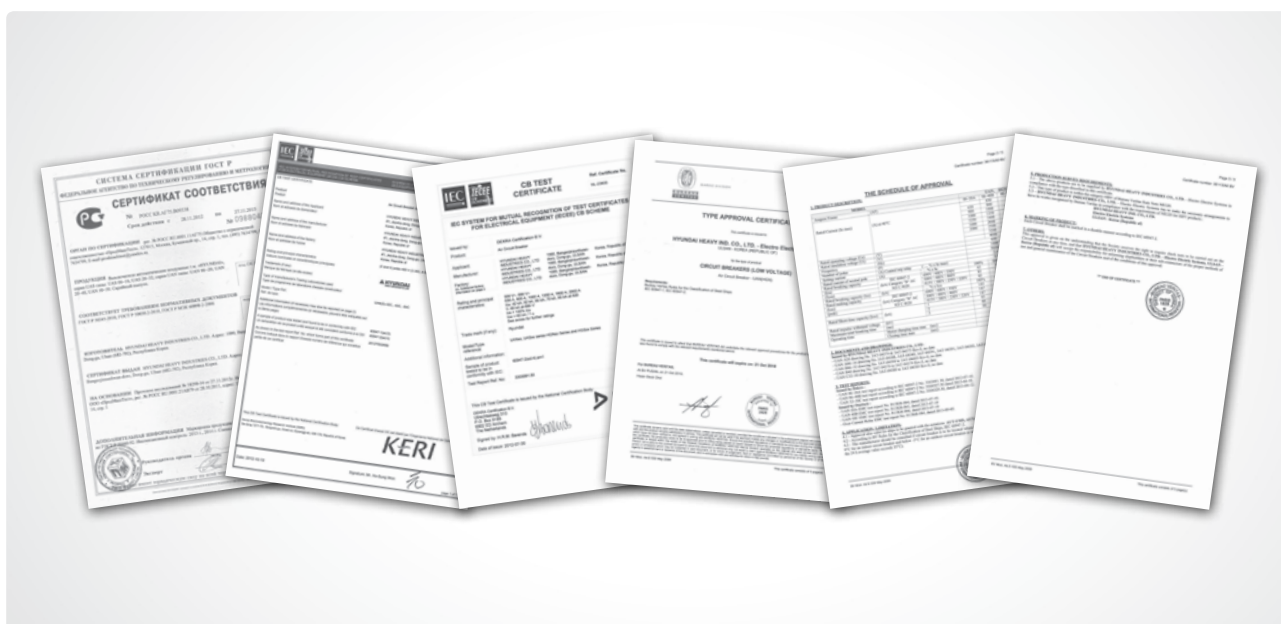

Features

| Various accessories |

[Body]

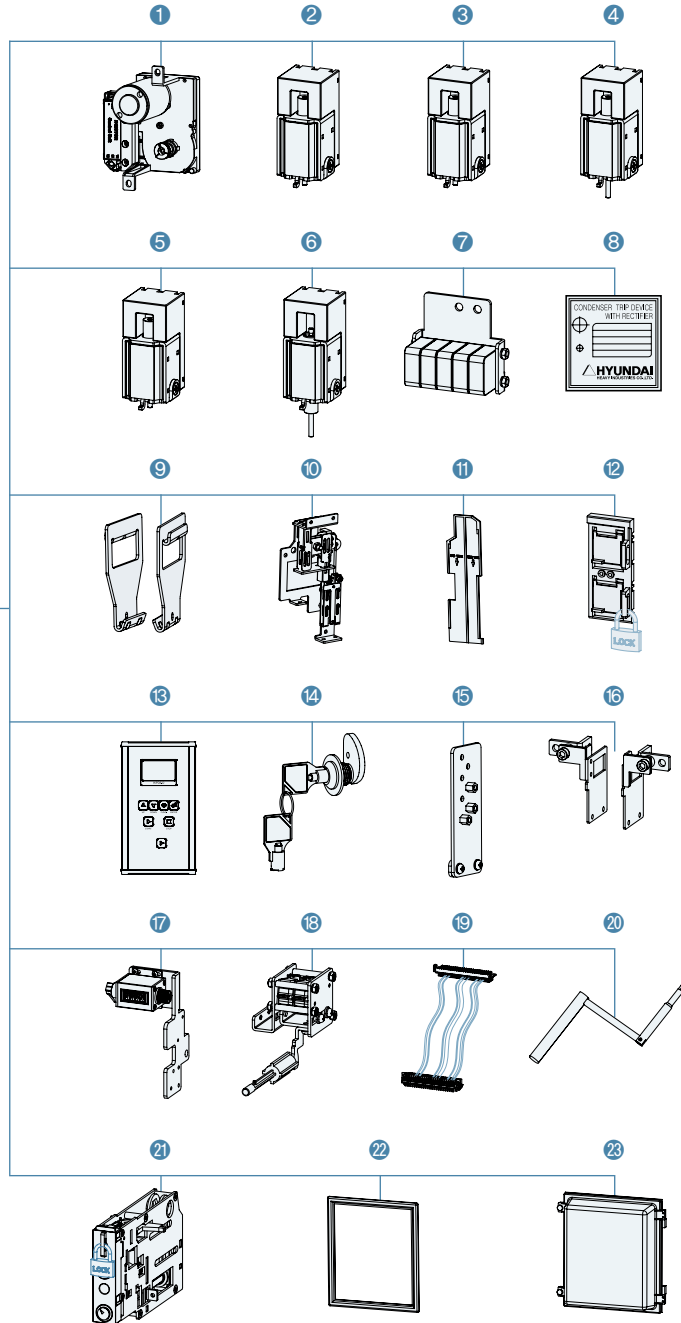

- | | | | |
|---------------------------|-----------------------------|------------------------------------|---|
| 1 Motor | 7 Auxiliary switch | 13 OCR portable checker | 19 Test jumper |
| 2 Closing coil | 8 Condenser trip device | 14 Key lock device | 20 Draw-in/out handle |
| 3 Trip coil | 9 Lifting lug | 15 Miss-insertion preventer | 21 Draw-in/out and position lock device |
| 4 Double trip coil | 10 Mechanical interlock kit | 16 Fixing block | 22 Door flange |
| 5 Trip supervision coil | 11 Phase insulation barrier | 17 Counter | 23 Dust cover |
| 6 Under voltage trip coil | 12 ON/OFF button cover | 18 OCR & Alarm switch reset device | |

[Cradle]

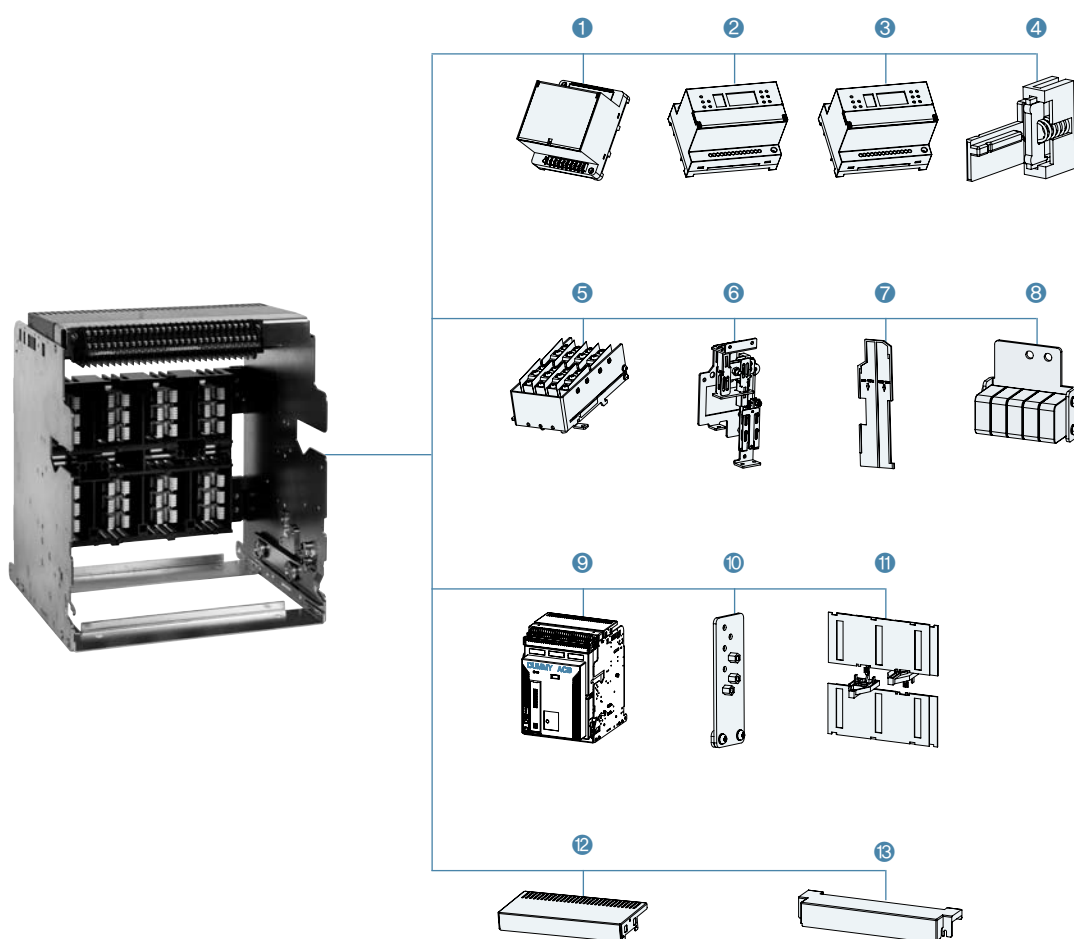

- ① UVT time delay controller
- ② Remote operation module
- ③ Temperature detection module
- ④ Short "b" contact
- ⑤ Position switch





- ⑥ Mechanical interlock kit
- ⑦ Phase insulation barrier
- ⑧ Mechanical operated cell (MOC) switch
- ⑨ Dummy ACB
- ⑩ Miss-insertion preventer





- ⑪ Safety shutter
- ⑫ Arc shield
- ⑬ Control terminal protection cover

Features

| High performance protection trip relay (OCR) |

- The protection trip relay (OCR) of U-Series ACB supports stable power supply with temperature alarm, fault recording, and others in addition to main protection functions.

Application		General feeder				
		N type	A type			P type
		UPR-LN	UPR-LA	UPR-LAG	UPR-LAZ	UPR-LP
Ordering code	50Hz	50	51	52	53	54
	60Hz	60	61	62	63	64
Externals						
Main function		<ul style="list-style-type: none"> • L/S/I/G • Thermal • Self-power • Fail safe • Intergrated instantaneous output contact 	<ul style="list-style-type: none"> • L/S/I/G • Thermal • Self-power • Fail safe • Communication (Modbus) • Control power • ZSI • Remote reset function • Individual continuous output contact: LTD, STD/INST, GFT, PTA • Fault recording 256ea • Record latest fault waveform (4 period, check by communication) • Event recording 200ea (check by communication) 	<ul style="list-style-type: none"> • L/S/I/ELT • Outer CT ground fault (Ground fault at more than 30A) → Using outer CT at secondary for 5A type. • Thermal • Self-power • Fail safe • Communication (Modbus) • Control power • ZSI • Remote reset function • Individual continuous output contact: LTD, STD/INST, PTA, ELT • Fault recording 256ea • Record latest fault waveform (4 period, check by communication) • Event recording 200ea (check by communication) 	<ul style="list-style-type: none"> • L/S/I/ELT • ZCT leakage (under 30A) → Using outer CT for 1,000:1A • Thermal • Self-power • Fail safe • Communication (Modbus) • Control power • ZSI • Remote reset function • Individual continuous output contact: LTD, STD/INST, PTA, ELT • Fault recording 256ea • Record latest fault waveform (4 period, check by communication) • Event recording 200ea (check by communication) 	<ul style="list-style-type: none"> • L/S/I/G • Thermal • Self-power • Fail safe • Communication (Modbus) • Control power • ZSI • Remote reset function • Individual continuous output contact: LTD, STD/INST, GFT, PTA • Fault recording 256ea • Record latest fault waveform (4 period, check by communication) • Event recording 200ea • Overload/Underload • Imbalance (voltage/current) • Reverse power • 3 phase voltage/Current RMS/Vector • Power (P,Q,S), power factor (3 phase) • Energy (normal/reverse direction) • Demand

Application		General feeder	Generator (Marine type)		
		H type	N type	A type	P type
		UPR-LH	UPR-SN	UPR-SA	UPR-SP
Ordering code	50Hz	55	57	58	59
	60Hz	65	67	68	69
Externals					
Main function		<ul style="list-style-type: none"> • L/S/I/G • Thermal • IDMTL • Self-power • Fail safe • Communication (Modbus) • Control power • ZSI • Remote reset function • Individual continuous output contact : LTD, STD/INST, GFT, PTA • Fault recording 256ea • Record latest fault waveform (4 period, check by communication) • Event recording 200ea • Overload/underload • Imbalance (voltage/current) • Reverse power • 3 phase voltage/ current RMS/vector • Power (P,Q,S), power factor (3 phase) • Energy (normal/reverse direction) • Frequency, demand • LTD, STD/INST, PTA, GFT fine control of current setting • Voltage/current harmonic wave (1st-63th) • Shows 3 phase waveform. • THD, TDD 	<ul style="list-style-type: none"> • L/S/I • Fine control of current • Thermal • Self-power • Fail safe • Integrated instantaneous output contact 	<ul style="list-style-type: none"> • L/S/I • Fine control of current • Thermal • Self-power • Fail safe • Communication (Modbus) • Control power • ZSI • Remote reset function • Individual continuous output contact : LTD, STD/INST, PTA • Fault recording 256ea • Record latest fault waveform (4 period, check by communication) • Event recording 200ea (check by communication) 	<ul style="list-style-type: none"> • L/S/I • Fine control of current • Thermal • Self-power • Fail safe • Communication (Modbus) • Control power • ZSI • Remote reset function • Individual continuous output contact : LTD, STD/INST, PTA • Fault recording 256ea • Record latest fault waveform (4 period, check by communication) • Event recording 200ea (check by communication) • Overload/underload • Imbalance (voltage/current) • Reverse power • 3 phase voltage/ current RMS/vector • Power (P,Q,S), power factor (3 phase) • Energy (normal/reverse direction) • Demand

Features

| Multiple terminal busbar connections |

- Increases the user's convenience by diversified terminal connection methods according to busbar's type.
- Simply turn a horizontal connector in 90° to make it a vertical connector (The opposite case is the same).

■ Standard connection

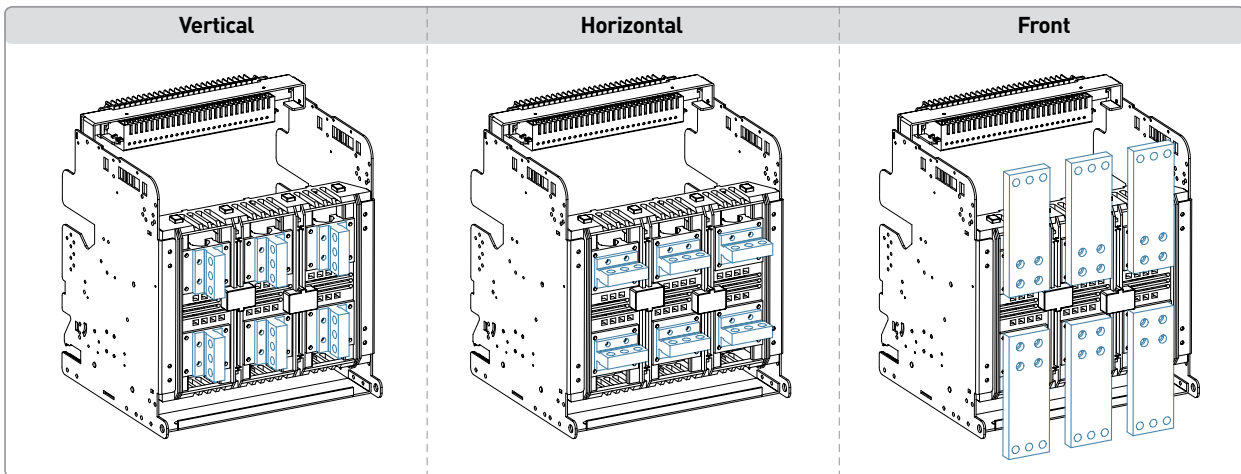

■ Mixed connection (Top/Bottom)

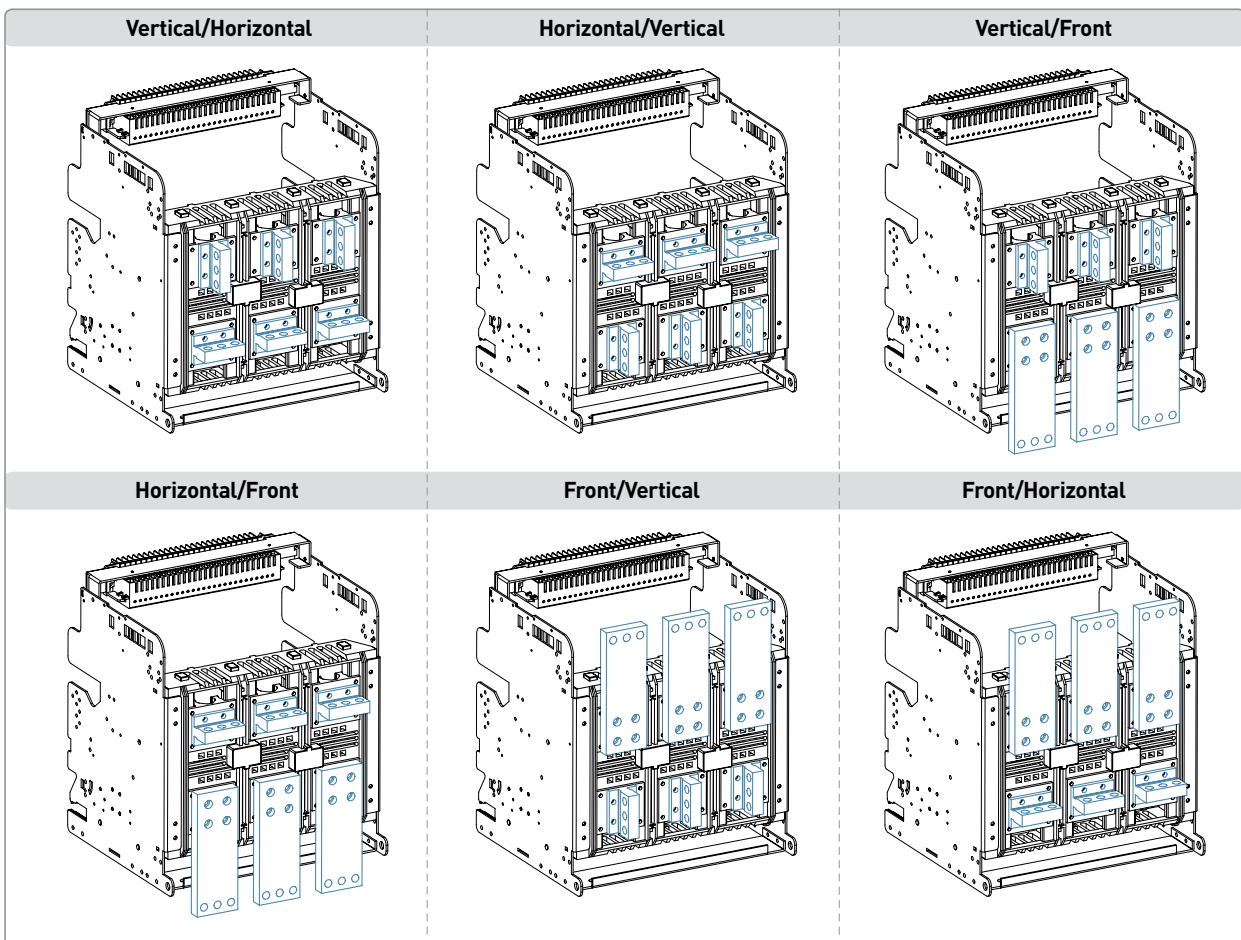

- ※ - Changing connector is available only for UAN/UAS A frame 630 - 1,600A, UAN/UAS B frame 2,000 - 3,200A.
 - Front connection type is suitable for panels with limited installation space.
 - When changing connections above 4,000A, additional component is needed. Please contact us.

| Easy-to-install |

■ Fixed type

- Installed in a switchboard directly.

■ Draw-out type

- Consists of ACB and cradle.
- Cradle is fixed to a switchboard.
- ACB may be in the position of CONNECTED, TEST, ISOLATED, and REMOVED.
- Switchboard door may be closed when (ACB is) in ISOLATED position.

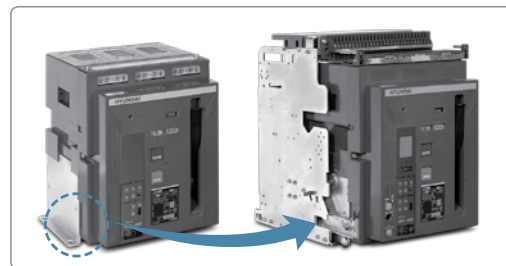

[Draw-in/out guide rail]

Connected position

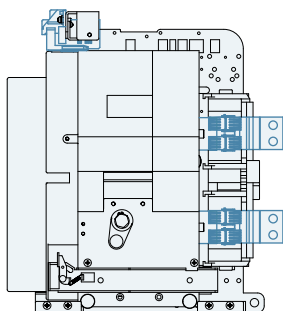

- Main and control circuit are all connected.
- Normal condition of use

Test position

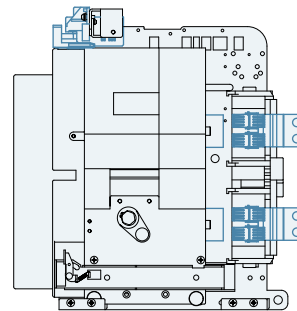

- Main circuit is isolated, control circuit is connected.
- Control test is possible when switchboard's door is closed.

Isolated position

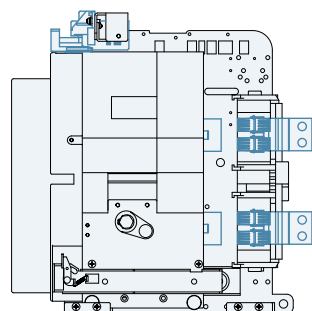

- Main and control circuit are all isolated.
- Switchboard door may be closed in isolated position.

Removed position

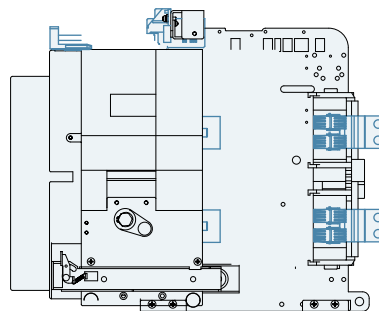

- ACB is totally drawn out from the cradle.

Structure

| Internals |

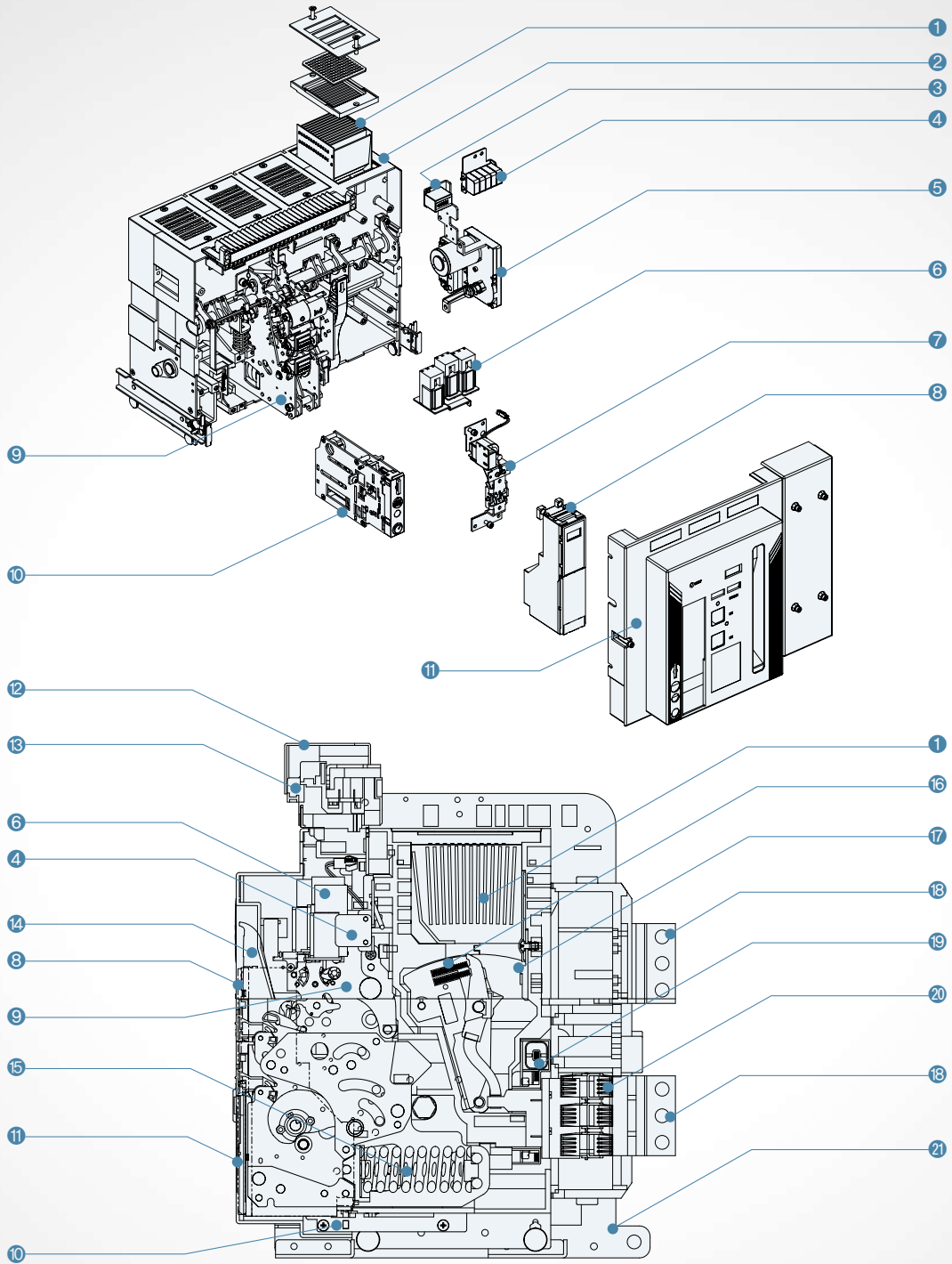

- | | | | |
|-------------------------|--------------------------------------|---------------------------|------------------------|
| 1 Arc chamber | 7 MHT device | 13 Control terminal | 19 Current transformer |
| 2 Frame | 8 Protection trip relay (OCR) | 14 Manual charging handle | 20 Terminal clip |
| 3 Counter | 9 Mechanism | 15 Closing spring | 21 Cradle |
| 4 Auxiliary switch | 10 Draw-in/out device | 16 Moving contact | |
| 5 Motor | 11 Front cover | 17 Fixed contact | |
| 6 Closing/Trip/UVT coil | 12 Control terminal protection cover | 18 Terminal busbar | |

| Externals |

[Front]

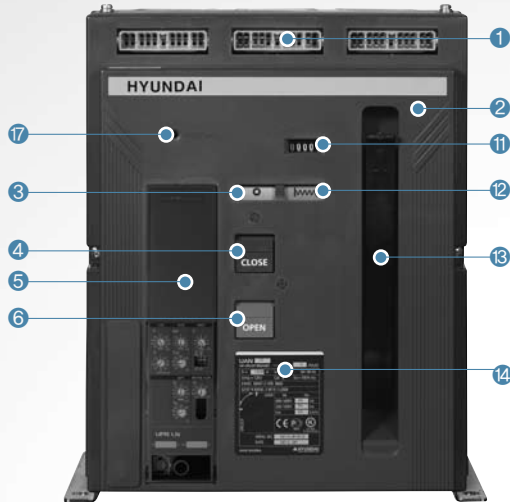

[Fixed type]

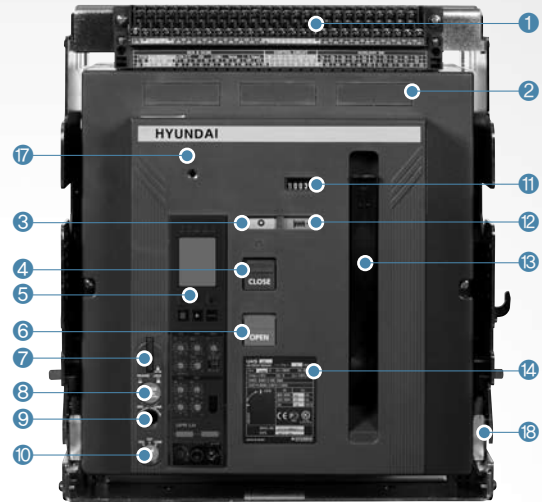

[Draw-out type]

[Cradle]

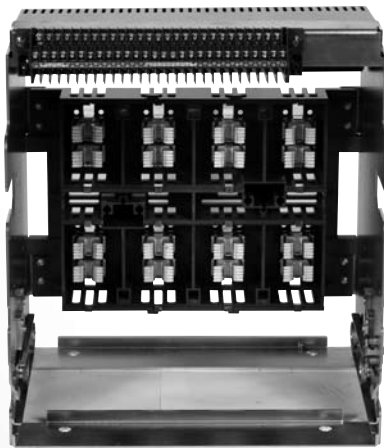

[Inside]



[Rear]

- | | | |
|-------------------------------|-------------------------------------|-----------------------------------|
| ① Control terminal | ⑦ Position lock device | ⑬ Manual charging handle |
| ② Front cover | ⑧ Position lock release button | ⑭ Name plate |
| ③ Close/Open indicator | ⑨ Draw-in/out handle insertion hole | ⑮ Arc shield |
| ④ Close button | ⑩ Position indicator | ⑯ Terminal busbar |
| ⑤ Protection trip relay (OCR) | ⑪ Counter | ⑰ OCR & Alarm switch reset button |
| ⑥ Open button | ⑫ Charged/Discharged indicator | ⑱ Draw-in/out guide rail |

Ratings

Frame			A frame	B frame	C frame	D frame ¹⁾	A frame	B frame
Model			UAN				UAS	
Recognition order code: Rated current (I _n max at 40°C) (A)			06 : 630	06 : 630	32 : 3,200	40 : 4,000	06 : 630	20 : 2,000
			08 : 800	08 : 800	40 : 4,000	50 : 5,000	08 : 800	25 : 2,500
			10 : 1,000	10 : 1,000	50 : 5,000	63 : 6,300	10 : 1,000	32 : 3,200
			12 : 1,250	12 : 1,250			12 : 1,250	
			16 : 1,600	16 : 1,600			16 : 1,600	
			20 : 2,000	20 : 2,000				
				25 : 2,500				
				32 : 3,200				
				40 : 4,000				
Rated operating voltage (U _e) (V)			AC690				AC690	
Rated insulation voltage (U _i) (V)			AC1,000				AC1,000	
Frequency (Hz)			50/60				50/60	
Number of poles			3, 4				3, 4	
Current setting range (..... x I _n max)			0.4 - 1.0				0.4 - 1.0	
Rated current of neutral pole (.....% x I _n)			100 %				100 %	
Rated breaking capacity (I _{cu}) (kA sym)	IEC 60947-2	AC690/600/550V	65	85	85	100	50	70
	category "B"	AC500/480/460V	85	100	100	150	65	85
	KS C 4620	AC415/380/230/220V	85	100	100	150	65	85
Rated service breaking capacity (.....% x I _{cu})			100 %				100 %	
Rated making capacity (I _{cm}) (kA peak)	IEC 60947-2	AC690/600/550V	143	187	187	220	105	154
	category "B"	AC500/480/460V	187	220	220	330	143	187
	KS C 4620	AC415/380/230/220V	187	220	220	330	143	187
Rated short-time capacity (I _{cw}) (kA, without Inst.)		1 sec	65	85	85	100	50	70
		2 sec	42	65	65	75	35	65
		3 sec	35	50	55	60	28	50
Rated impulse withstand voltage (U _{imp}) (kV)			12				12	
Maximum total breaking time (ms)			40				40	
Closing operating time	Motor charging time (sec) max.		10				10	
	Closing time (ms) max.		80				80	
Life cycle (times)	Mechanical	Without maintenance	20000	20000	10000	5000	20000	20000
		With maintenance	30000	30000	15000	10000	30000	30000
	Electrical	Without maintenance	5000	20 - 5000 25 - 40 : 3000	2000	2000	5000	5000
		With maintenance	10000	20 - 10000 25 - 40 : 8000	5000	5000	10000	10000
Weight (kg)	3 pole	Draw-out type	63	06 - 32 : 87 40 : 107	145	169	63	87
		Fixed type	34	06 - 32 : 44 40 : 61	76	108	34	44
	4 pole	Draw-out type	74	06 - 32 : 103 40 : 61	173	214	74	103
		Fixed type	44	06 - 32 : 55 40 : 81	81	137	44	55
External dimension (mm) (WxHxD, except busbar)	3 pole	Draw-out type	328 x 460 x 368	399 x 460 x 368	624 x 460 x 368	766 x 460 x 368,4	328 x 460 x 368	399 x 460 x 368
		Fixed type	337 x 404 x 296	408 x 404 x 296	633 x 404 x 296	775,4x404,4x295,8	337 x 404 x 296	408 x 404 x 296
	4 pole	Draw-out type	413 x 460 x 368	514 x 460 x 368	794 x 460 x 368	996 x 460 x 368,4	413 x 460 x 368	514 x 460 x 368
		Fixed type	422 x 404 x 296	523 x 404 x 296	803 x 404 x 296	1005x404,4x295,8	422 x 404 x 296	523 x 404 x 296

※ D frame will be available from 2015-1st half.

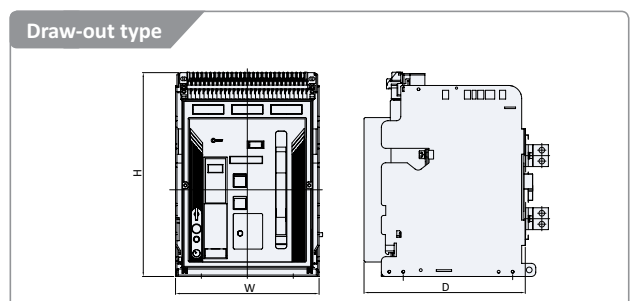
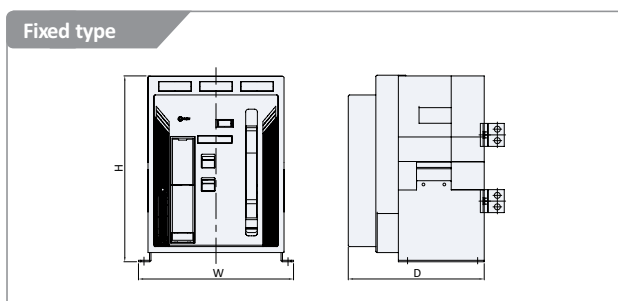

Protection Trip Relay (OCR)



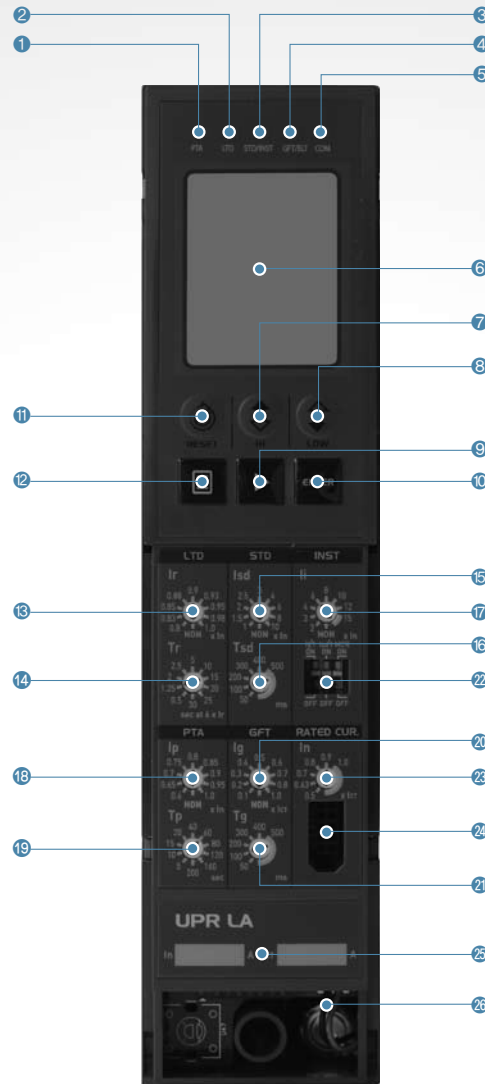





| Overview |



- | | | |
|------------------------|------------------------|--|
| ① PTA signal LED | ⑪ Reset button | ⑳ GFT/ELT pick up setting |
| ② LTD signal LED | ⑫ Menu button | ㉑ GFT/ELT time setting |
| ③ STD/INST signal LED | ⑬ LTD pick up setting | ㉒ GFT/STD (Inverse time setting),
MCR ON/OFF setting switch |
| ④ GFT/ELT signal LED | ⑭ LTD time setting | ㉓ In (Rated current) setting |
| ⑤ Com. signal LED | ⑮ STD pick up setting | ㉔ Temporary test connection jack |
| ⑥ LCD panel | ⑯ STD time setting | ㉕ Model name |
| ⑦ STD/INST test button | ⑰ INST pick up setting | ㉖ Battery |
| ⑧ LTD test button | ⑱ PTA pick up setting | |
| ⑨ Movement button | ⑲ PTA time setting | |
| ⑩ Enter button | | |

※ Self power works normally at larger than 10 % for 3 phase, 30 % for single phase.
 But in case of using 200A CT , larger than 15 % for 3 phase, 100 % for single phase.
 ※ Mark BB when ordering if you use MCR function. Auxiliary contacting point is 4a5b.

Protection Trip Relay (OCR)

Type		General feeder						Generator (Marine type)			
		N type	A type				P type	H type	N type	A type	P type
		UPR-LN	UPR-LA	UPR-LAG	UPR-LAZ	UPR-LP	UPR-LH	UPR-SN	UPR-SA	UPR-SP	
Ordering code	50Hz	50	51	52	53	54	55	57	58	59	
	60Hz	60	61	62	63	64	65	67	68	69	
Externals											
Control power	External power	—	●	●	●	●	●	—	●	●	
	Self-power	●	●	●	●	●	●	●	●	●	
Protection function	LTD(Long time delay)	●	●	●	●	●	●	●	●	●	
	STD(Short time delay)	●	●	●	●	●	●	●	●	●	
	INST(Instantaneous trip)	●	●	●	●	●	●	●	●	●	
	Pre-trip alarm	—	●	●	●	●	●	—	●	●	
	Ground fault trip	●	●	—	—	●	●	—	—	—	
	ELT	—	—	● Outer CT ground fault type (Ground fault at more than 30A)	● Outer CT leakage type (Under 30A)	—	—	—	—	—	
	Thermal	●	●	●	●	●	●	●	●	●	
	Field test	—	●	●	●	●	●	—	●	●	
Fail safe	●	●	●	●	●	●	●	●	●		
Indication	True RMS	●	●	●	●	●	●	●	●	●	
	Trip LED	—	●	●	●	●	●	—	●	●	
	Fault LED	L	L/S/I, G, PTA	L/S/I, ELT, PTA	L/S/I, ELT, PTA	L/S/I, G, PTA	L/S/I, G, PTA	L	L/S/I, PTA	L/S/I, PTA	
	Load factor LCD	—	●	●	●	●	●	—	●	●	
	Measurement LCD	—	●	●	●	●	●	—	●	●	
Digital output	Integrated instantaneous contact(1a)	●	—	—	—	—	—	—	—	—	
	Integrated continuous contact(4a)	—	●	●	●	●	●	—	● ¹⁾	● ¹⁾	
Option	MCR	—	○	○	○	○	○	—	○	○	
	Communication	—	●	●	●	●	●	—	●	●	
	Event/Fault recording	—	●	●	●	●	●	—	●	●	

※ ●: Standard ○: Option

1) Individual continuous contact 3a (In case of marine type)

| UPR-LN (50,60) |



- Overload protection
 - Long time delay
- Short circuit protection
 - Short time delay, instantaneous trip
 - I²t on/off optional (for STD)
- Ground fault protection
 - I²t on/off optional (for GFT)
- Neutral wire protection
 - 3P: No protection
 - 4P: 100 % x I_n
 - LTD, STD, INST protection
- Self power
- 1a DO (digital output)
 - Contact specification

Rating	Nominal switching capacity (resistive load)	5A 277VAC
	Max. switching power (resistive load)	1,385VA
	Max. switching voltage	277VAC
	Max. switching current	5A
	Max. switching capacity (reference value)	100mA 5VDC

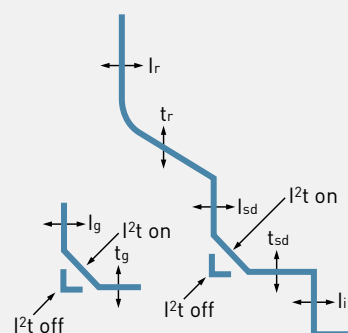

■ Protection

Long time	Current setting (A)	$I_n = I_{ct} \times \dots$	0.5	0.63	0.7	0.8	0.9	1					
		$I_r = I_n \times \dots$	0.8	0.83	0.85	0.88	0.9	0.93	0.95	0.98	1	Non	
	Time delay (sec) Accuracy: $\pm 15\%$ or below 100ms		tr at (1.5×I _r)	10.4	26.1	41.7	52	104	208	312	417	521	626
			tr at (6.0×I _r)	0.5	1.25	2	2.5	5	10	15	20	25	30
			tr at (7.2×I _r)	0.35	0.86	1.38	1.73	3.45	6.9	10.4	13.8	17.3	20.7
Short time	Current setting (A) Accuracy: $\pm 15\%$	$I_{sd} = I_n \times \dots$	1	1.5	2	2.5	3	4	6	8	10	Non	
	Time delay (sec) at 10×I _r	tsd	I ² t off	0.05	0.1	0.2	0.3	0.4	0.5				
			I ² t on	0.05	0.1	0.2	0.3	0.4	0.5				
		(I ² t off)	Min. trip time (ms)	20	80	160	260	360	460				
			Max. trip time (ms)	80	140	240	340	440	540				
Instantaneous	Current setting (A)	$I_i = I_n \times \dots$	2	3	4	6	8	10	12	15	Non		
	Trip time		below 50ms										
Ground fault	Pick-up (A) Accuracy: $\pm 15\%$ (I _g > 0.4I _n) $\pm 20\%$ (I _g ≤ 0.4I _n)	$I_g = I_{ct} \times \dots$	0.1	0.2	0.3	0.4	0.5	0.6	0.7	0.8	1	Non	
	Time delay (sec) at 1×I _n Accuracy: $\pm 20\%$	tg	I ² t off	0.05	0.1	0.2	0.3	0.4	0.5				
			I ² t on	0.05	0.1	0.2	0.3	0.4	0.5				
		(I ² t off)	Min. trip time (ms)	20	80	160	260	360	460				
			Max. trip time (ms)	80	140	240	340	440	540				

Protection Trip Relay (OCR)

| UPR-LA (51,61) |



- Overload protection
 - Long time delay
 - Thermal function
- Short circuit protection
 - Short time delay, instantaneous trip
 - I²t on/off optional (for STD)
- Ground fault protection
 - I²t on/off optional (for GFT)
- Neutral wire protection
 - 3 Pole: No protection
 - 4 Pole: Non, 50 %, 100 % (x I_r, I_{sd}, I_i)
- Measurement and Display
 - 3 phase current
- Realization of protective coordination by ZSI (zone selective interlocking)
- Fault recording
 - Record up to 256 fault information about fault type, fault phase, fault value, occurrence time of fault.
 - Record latest fault waveform (4 period, check by communication)
- Event recording
 - Record events of device related to setting change, operation and state change up to 200
- Pre-trip alarm
 - Prevent unnecessary over load trip according to rated current (I_n)
- Field test
 - Simulation of long time, short time, instantaneous
- Communication: RS-485/Modbus-RTU

- 4a DO (digital output)
- Contact specification

Rating	Nominal switching capacity (resistive load)	5A 277VAC
	Max. switching power (resistive load)	1,385VA
	Max. switching voltage	277VAC
	Max. switching current	5A
	Max. switching capacity (reference value)	100mA 5VDC

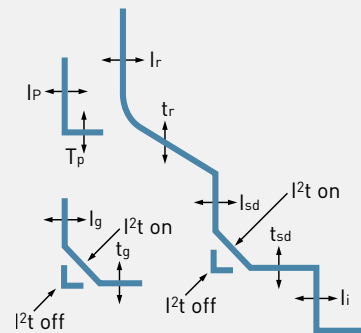

■ Protection

Long time	Current setting (A)	I _n = I _{ct} ×...	0.5	0.63	0.7	0.8	0.9	1				
			I _r = I _n ×...	0.8	0.83	0.85	0.88	0.9	0.93	0.95	0.98	1
	Time delay (sec) Accuracy: ±15 % or below 100ms	tr at (1.5×I _r)	10.4	26.1	41.7	52	104	208	312	417	521	626
		tr at (6.0×I _r)	0.5	1.25	2	2.5	5	10	15	20	25	30
		tr at (7.2×I _r)	0.35	0.86	1.38	1.73	3.45	6.9	10.4	13.8	17.3	20.7
Short time	Current setting (A) Accuracy: ±15 %	I _{sd} = I _n ×...	1	1.5	2	2.5	3	4	6	8	10	Non
	Time delay (sec) at 10×I _r	tsd	I ² t off	0.05	0.1	0.2	0.3	0.4	0.5			
			I ² t on	0.05	0.1	0.2	0.3	0.4	0.5			
		(I ² t off)	Min. trip time (ms)	20	80	160	260	360	460			
Max. trip time (ms)	80		140	240	340	440	540					
Instantaneous	Current setting (A) Trip time	I _i = I _n ×...	2	3	4	6	8	10	12	15	Non	
			below 50ms									
Ground fault	Pick-up (A) Accuracy: ±15 % (I _g >0.4I _n) ±20 % (I _g ≤0.4I _n)	I _g = I _{ct} ×...	0.1	0.2	0.3	0.4	0.5	0.6	0.7	0.8	1	Non
	Time delay (sec) at 1×I _n Accuracy: ±20 %	t _g	I ² t off	0.05	0.1	0.2	0.3	0.4	0.5			
			I ² t on	0.05	0.1	0.2	0.3	0.4	0.5			
		(I ² t off)	Min. trip time (ms)	20	80	160	260	360	460			
Max. trip time (ms)	80		140	240	340	440	540					
Pre trip alarm	Current setting (A) Accuracy: ±15 %	I _p = I _n ×...	0.6	0.65	0.7	0.75	0.8	0.85	0.9	0.95	1	Non
	Time delay (sec)	t _p at (I _p ×1.2)	5	10	15	20	40	60	80	120	160	

| UPR-LAG (52,62) |



- Overload protection
 - Long time delay
 - Thermal function
- Short circuit protection
 - Short time delay, instantaneous trip
 - I²t on/off optional (for STD)
- Earth leakage protection
 - Use ZCT for 5A output at secondary (3 % tolerance)
 - GPR setting calculation is done with reference 5A at secondary ex) When using 100:5A, in order to work primary working at 30A, 30x5/100 = 1.5A, GPR set to 2A,
- Neutral wire protection
 - 3 Pole: No protection
 - 4 Pole: Non, 50 %, 100 % (x I_r, I_{sd}, I_i)
- Measurement and Display
 - 3 phase current
- Realization of protective coordination by ZSI (zone selective interlocking)
- Fault recording
 - Record up to 256 fault information about fault type, fault phase, fault value, occurrence time of fault.
 - Record latest fault waveform (4 period, check by communication)
- Event recording
 - Record events of device related to setting change, operation and state change up to 200
- Pre-trip alarm
 - Prevent unnecessary over load trip according to rated current (I_n)

- Field test
 - Simulation of long time, short time, instantaneous delay
- Communication: RS-485/Modbus-RTU
- 4a DO (digital output)
 - Contact specification

Rating	Nominal switching capacity (resistive load)	5A 277VAC
	Max. switching power (resistive load)	1,385VA
	Max. switching voltage	277VAC
	Max. switching current	5A
	Max. switching capacity (reference value)	100mA 5VDC

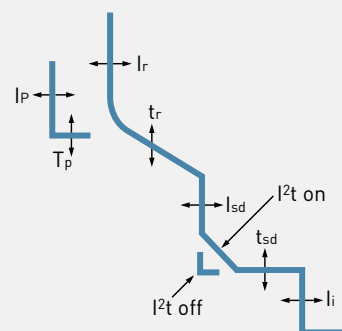

■ Protection

Long time	Current setting (A)	I _n = I _{ct} ×...	0.5	0.63	0.7	0.8	0.9	1				
			I _r = I _n ×...	0.8	0.83	0.85	0.88	0.9	0.93	0.95	0.98	1
	Time delay (sec) Accuracy: ±15 % or below 100ms	tr at (1.5×I _r)	10.4	26.1	41.7	52	104	208	312	417	521	626
		tr at (6.0×I _r)	0.5	1.25	2	2.5	5	10	15	20	25	30
		tr at (7.2×I _r)	0.35	0.86	1.38	1.73	3.45	6.9	10.4	13.8	17.3	20.7
Short time	Current setting (A) Accuracy: ±15 %	I _{sd} = I _n ×...	1	1.5	2	2.5	3	4	6	8	10	Non
	Time delay (sec) at 10×I _r	t _{sd}	I ² t off	0.05	0.1	0.2	0.3	0.4	0.5			
			I ² t on	0.05	0.1	0.2	0.3	0.4	0.5			
		(I ² t off)	Min. trip time (ms)	20	80	160	260	360	460			
			Max. trip time (ms)	80	140	240	340	440	540			
Instantaneous	Current setting (A)	I _i = I _n ×...	2	3	4	6	8	10	12	15	Non	
	Trip time		below 50ms									
Pre trip alarm	Current setting (A) Accuracy: ±15 %	I _p = I _n ×...	0.6	0.65	0.7	0.75	0.8	0.85	0.9	0.95	1	Non
	Time delay (sec)	tp at (I _p ×1.2)	5	10	15	20	40	60	80	120	160	200
Earth leakage	Current setting (A)	IΔn	0.5	0.8	1	2	3	5	Non			
	Time delay (ms) Accuracy: ±15 % or below 40ms	Δt	Alarm time (ms)	140	230	350	800	950				
			Trip time (ms)	60	140	230	350	800				

Protection Trip Relay (OCR)

| UPR-LAZ (53,63) |



- Overload protection
 - Long time delay
 - Thermal function
- Short circuit protection
 - Short time delay, instantaneous trip
 - I²t on/off optional (for STD)
- Earth leakage protection
 - You should use 1000:1 ZCT specification
 - OCR operate its primary as a reference
- Neutral wire protection
 - 3 Pole: No protection
 - 4 Pole: Non, 50 %, 100 % (x I_e, I_{sd}, I_i)
- Measurement and display
 - 3 phase current
- Realization of protective coordination by ZSI (zone selective interlocking)
- Fault recording
 - Record up to 256 fault information about fault type, fault phase, fault value, occurrence time of fault.
 - Record latest fault waveform (4 period, check by communication)
- Event recording
 - Record events of device related to setting change, operation and state change up to 200
- Pre-trip alarm
 - Prevent unnecessary over load trip according to rated current (I_n)
- Field test
 - Simulation of long time, short time, instantaneous
- Communication : RS-485/Modbus-RTU

- 4a DO (digital output)
- Contact specification

Rating	Nominal switching capacity (resistive load)	5A 277VAC
	Max. switching power (resistive load)	1,385VA
	Max. switching voltage	277VAC
	Max. switching current	5A
	Max. switching capacity (reference value)	100mA 5VDC

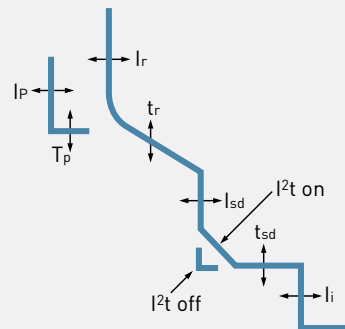

■ Protection

Long time	Current setting (A)	I _n = I _{ct} ×...	0.5	0.63	0.7	0.8	0.9	1						
			I _r = I _n ×...	0.8	0.83	0.85	0.88	0.9	0.93	0.95	0.98	1	Non	
	Time delay (sec) Accuracy: ±15 % or below 100ms	tr at (1.5×I _r)	10.4	26.1	41.7	52	104	208	312	417	521	626		
		tr at (6.0×I _r)	0.5	1.25	2	2.5	5	10	15	20	25	30		
		tr at (7.2×I _r)	0.35	0.86	1.38	1.73	3.45	6.9	10.4	13.8	17.3	20.7		
Short time	Current setting (A) Accuracy: ±15 %	I _{sd} = I _n ×...		1	1.5	2	2.5	3	4	6	8	10	Non	
		Time delay (sec) at 10×I _r	tsd	I ² t off	0.05	0.1	0.2	0.3	0.4	0.5				
	I ² t on			0.05	0.1	0.2	0.3	0.4	0.5					
	(I ² t off)		Min. trip time (ms)	20	80	160	260	360	460					
		Max. trip time (ms)	80	140	240	340	440	540						
Instantaneous	Current setting (A)	I _i = I _n ×...	2	3	4	6	8	10	12	15	Non			
	Trip time		below 50ms											
Pre trip alarm	Current setting (A) Accuracy: ±15 %	I _p = I _n ×...	0.6	0.65	0.7	0.75	0.8	0.85	0.9	0.95	1	Non		
	Time delay (sec)	tp at (I _p ×1.2)	5	10	15	20	40	60	80	120	160	200		
Earth leakage	Current setting (A)	IΔn	0.5	1	2	3	5	10	20	30	Non			
	Time delay (ms) Accuracy: ±15 % or below 40ms	Δt	Alarm time (ms)	140	230	350	800	950						
			Trip time (ms)	60	140	230	350	800						

| UPR-LP (54,64), UPR-LH (55,65) |



- Overload protection
 - Long time delay
 - Thermal function
- Short circuit protection
 - Short time delay, instantaneous trip
 - I^2t on/off optional (for STD)
- Ground fault protection
 - I^2t on/off optional (for GFT)
- Neutral wire protection
 - 3 Pole: No protection
 - 4 Pole: Non, 50 %, 100 % (x Ir, I_{sd}, I_{li})
- Overload/underload/voltage imbalance protection
- Measurement and display
 - 3 phase current/voltage/power/power factor/energy/phase/demand
- Realization of protective coordination by ZSI (zone selective interlocking)
- Fault recording
 - Record up to 256 fault information about fault type, fault phase, fault value, occurrence time of fault.
 - Record latest fault waveform (4 period, check by communication)
- Event recording
 - Record events of device related to setting change, operation and state change up to 200
- Pre-trip alarm
 - Prevent unnecessary over load trip according to rated current (I_n)
- Field test
 - Simulation of long time, short time, instantaneous

- Communication: RS-485/Modbus-RTU
- 4a DO (digital output)
 - Contact specification

Rating	Nominal switching capacity (resistive load)	5A 277VAC
	Max. switching power (resistive load)	1,385VA
	Max. switching voltage	277VAC
	Max. switching current	5A
	Max. switching capacity (reference value)	100mA 5VDC

- Must install voltage module
- Additional function in LH type
 - 3 phase waveform
 - THD, TDD

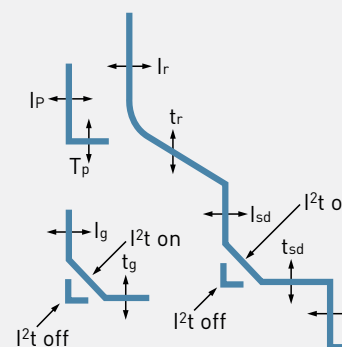

■ Protection

Long time	Current setting (A)	$I_n = I_{ct} \times \dots$	0.5	0.63	0.7	0.8	0.9	1					
			$I_r = I_n \times \dots$	0.8	0.83	0.85	0.88	0.9	0.93	0.95	0.98	1	Non
	Time delay (sec)	tr at (1.5×I _r)	10.4	26.1	41.7	52	104	208	312	417	521	626	
	Accuracy: ±15 % or below 100ms	tr at (6.0×I _r)	0.5	1.25	2	2.5	5	10	15	20	25	30	
		tr at (7.2×I _r)	0.35	0.86	1.38	1.73	3.45	6.9	10.4	13.8	17.3	20.7	
Short time	Current setting (A)	$I_{sd} = I_n \times \dots$	1	1.5	2	2.5	3	4	6	8	10	Non	
	Time delay (s) at 10×I _r	tsd	I ² t off	0.05	0.1	0.2	0.3	0.4	0.5				
			I ² t on	0.05	0.1	0.2	0.3	0.4	0.5				
		I ² t off	Min. trip time (ms)	20	80	160	260	360	460				
Max. trip time (ms)			80	140	240	340	440	540					
Instantaneous	Current setting (A)	$I_i = I_n \times \dots$	2	3	4	6	8	10	12	15	Non		
	Trip time		below 50ms										
Ground fault	Pick-up (A)	$I_g = I_{ct} \times \dots$	0.1	0.2	0.3	0.4	0.5	0.6	0.7	0.8	1	Non	
	Accuracy: ±15 % (I _g > 0.4I _n) ±20 % (I _g ≤ 0.4I _n)	Time delay (sec) at 1×I _n	tg	I ² t off	0.05	0.1	0.2	0.3	0.4	0.5			
				I ² t on	0.05	0.1	0.2	0.3	0.4	0.5			
		Accuracy: ±20 %	I ² t off	Min. trip time (ms)	20	80	160	260	360	460			
Max. trip time (ms)				80	140	240	340	440	540				
Pre trip alarm	Current setting (A)	$I_p = I_n \times \dots$	0.6	0.65	0.7	0.75	0.8	0.85	0.9	0.95	1	Non	
	Accuracy: ±15 %												
	Time delay (sec)	tp at (I _p ×1.2)	5	10	15	20	40	60	80	120	160	200	

Protection Trip Relay (OCR)

| UPR-SN (57,67) |



- Overload protection
 - Long time delay
- Short circuit protection
 - Short time delay, instantaneous trip
 - I²t on/off optional (for STD)
- Self power
- 1a DO (digital output)
 - Contact specification

Rating	Nominal switching capacity (resistive load)	5A 277VAC
	Max. switching power (resistive load)	1,385VA
	Max. switching voltage	277VAC
	Max. switching current	5A
	Max. switching capacity (reference value)	100mA 5VDC

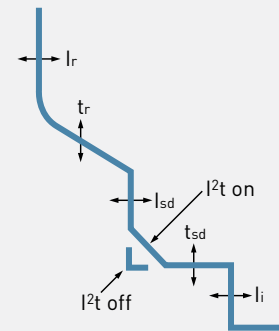

■ Protection

	Current setting (A)	In = Ict×...		(0.5-1.0) x1 % unit, or 1A unit															
		Ir = In×...																	
Long time	Time delay (sec) Accuracy: ±15 % or below 100ms	tr at (1.05×Ir)	20	30	40	50	60	70	80	100	120								
		tr at (1.2×Ir)	10	15	20	25	30	35	40	50	60								
		tr at (3×Ir)	0.99	1.49	1.99	2.48	2.98	3.48	3.97	4.97	5.96								
Short time	Time delay (sec) at 10×Ir	tsd	I ² t off	0.05	0.1	0.2	0.3	0.4	0.5										
			I ² t on	0.05	0.1	0.2	0.3	0.4	0.5										
		(I ² t off)	Min. trip time (ms)	20	80	160	260	360	460										
			Max. trip time (ms)	80	140	240	340	440	540										
Instantaneous	Current setting (A)	Ii = In×...	2	3	4	6	8	10	12	15	Non								
	Trip time		below 50ms																

| UPR-SA (58,68) |



- Overload protection
 - Long time delay
- Short circuit protection
 - Short time delay, instantaneous trip
 - I²t on/off optional (for STD)
- Fine control of I_n
 - Control by 1A unit in 0.5-1 I_{ct} range
 - Adjustable using button through front monitor
- Realization of protective coordination by ZSI (zone selective interlocking)
- Fault recording
 - Record up to 256 fault information about fault type, fault phase, fault value, occurrence time of fault.
 - Record latest fault waveform (4 period, check by communication)
- Event recording
 - Record events of device related to setting change, operation and state change up to 200
- Pre-trip alarm
 - Prevent unnecessary over load trip according to rated current (I_n)
- Field test
 - Simulation of long time, short time, instantaneous
- Communication: RS-485/Modbus-RTU

- 3a DO (digital output)
- Contact specification

Rating	Nominal switching capacity (resistive load)	5A 277VAC
	Max. switching power (resistive load)	1,385VA
	Max. switching voltage	277VAC
	Max. switching current	5A
	Max. switching capacity (reference value)	100mA 5VDC

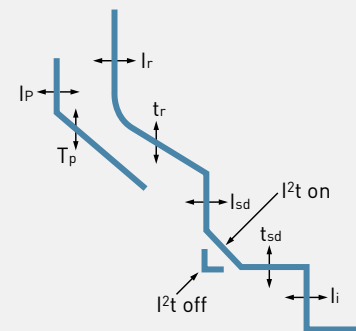

■ Protection

	Current setting (A)	I _n = I _{ct} ×...	[0.5 - 1.0] x1 % unit, or 1A unit										
			I _r = I _n ×...	0.7	0.8	0.9	1	1.05	1.1	1.15	1.2	1.25	Non
Long time	Time delay (sec) Accuracy: ±15 % or below 100ms	tr at (1.05×I _r)	20	30	40	50	60	70	80	100	120		
		tr at (1.2×I _r)	10	15	20	25	30	35	40	50	60		
		tr at (3×I _r)	0.99	1.49	1.99	2.48	2.98	3.48	3.97	4.97	5.96		
Short time	Current setting (A) Accuracy: ±15 % Time delay (sec) at 10×I _r	I _{sd} = I _n ×...	1	1.5	2	2.5	3	3.5	4	4.5	5	Non	
		tsd	I ² t off	0.05	0.1	0.2	0.3	0.4	0.5				
			I ² t on	0.05	0.1	0.2	0.3	0.4	0.5				
		I ² t off	Min. trip time (ms)	20	80	160	260	360	460				
Max. trip time (ms)	80		140	240	340	440	540						
Instantaneous	Current setting (A)	I _i = I _n ×...	2	3	4	6	8	10	12	15	Non		
	Trip time		below 50ms										
Pre trip alarm	Current setting (A) Accuracy: ±15 %	I _p = I _n ×...	0.7	0.75	0.8	0.85	0.9	0.95	1	1.05	1.1	Non	
	Time delay (sec)	tp at (I _p ×1.2)	1	5	10	15	20	25	30	35	40		

Protection Trip Relay (OCR)

| UPR-SP (59,69) |



- Overload protection
 - Long time delay
 - Thermal function
- Short circuit protection
 - Short time delay, instantaneous trip
 - I²t on/off optional (for STD)
- Neutral wire protection
 - 3 Pole: No protection
 - 4 Pole: Non, 50 %, 100 % (x I_r, I_{sd}, I_i)
- Overload/Underload/ Voltage Imbalance protection
- Measurement and Display
 - 3 phase current/voltage/power/ power factor/energy/phase/demand
- Realization of protective coordination by ZSI (zone selective interlocking)
- Fault recording
 - Record up to 256 fault information about fault type, fault phase, fault value, occurrence time of fault.
 - Record latest fault waveform (4 period, check by communication)
- Event recording
 - Record events of device related to setting change, operation and state change up to 200
- Pre-trip alarm
 - Prevent unnecessary over load trip according to rated current (I_n)
- Field test
 - Simulation of long time, short time, instantaneous
- Communication: RS-485/Modbus-RTU

- 3a DO (digital output)
- Contact specification

Rating	Parameter	Value
	Nominal switching capacity (resistive load)	5A 277VAC
	Max. switching power (resistive load)	1,385VA
	Max. switching voltage	277VAC
	Max. switching current	5A
	Max. switching capacity (reference value)	100mA 5VDC

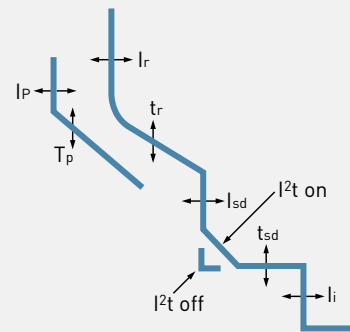

■ Protection

Long time	Current setting (A)	I _n = I _{ct} ×...	(0.5-1.0) x1 % unit, or 1A unit									
			I _r = I _n ×...	0.7	0.8	0.9	1	1.05	1.1	1.15	1.2	1.25
Time delay (sec) Accuracy: ±15 % or below 100ms		tr at (1.05×I _r)	20	30	40	50	60	70	80	100	120	
		tr at (1.2×I _r)	10	15	20	25	30	35	40	50	60	
		tr at (3×I _r)	0.99	1.49	1.99	2.48	2.98	3.48	3.97	4.97	5.96	
Short time	Current setting (A) Accuracy: ±15 %	I _{sd} = I _n ×...	1	1.5	2	2.5	3	4	6	8	10	Non
		Time delay (sec) at 10×I _r	tsd	I ² t off	0.05	0.1	0.2	0.3	0.4	0.5		
				I ² t on	0.05	0.1	0.2	0.3	0.4	0.5		
			(I ² t off)	Min. trip time(ms)	20	80	160	260	360	460		
Max. trip time(ms)	80			140	240	340	440	540				
Instantaneous	Current setting (A)	I _i = I _n ×...	2	3	4	6	8	10	12	15	Non	
	Trip time		below 50ms									
Pre trip alarm	Current setting (A) Accuracy: ±15 %	I _p = I _n ×...	0.6	0.65	0.7	0.75	0.8	0.85	0.9	0.95	1	Non
	Time delay (sec)	tp at (I _p ×1.2)	5	10	15	20	40	60	80	120	160	

Operation characteristics |

Long time delay (LTD)

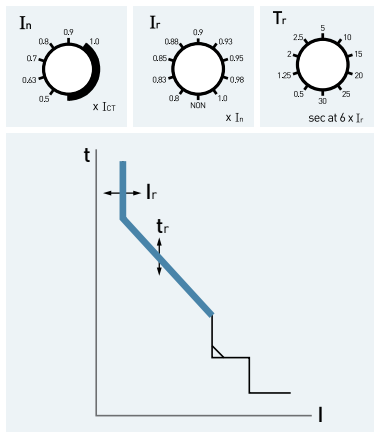

Standard current setting

L type

- The scale is marked as magnification of $[I_n]$.
- Setting range: (Non, 0.8, 0.83, 0.85, 0.88, 0.9, 0.93, 0.95, 0.98, 1.0) $\times I_n$ (10 steps)
- No protection in case of non setting of $[I_r]$.
- The breaker does not trip below 105 % of $[I_r]$, and trip at 120 % and above.

S type

- Setting range: (Non, 0.7, 0.8, 0.9, 1.0, 1.05, 1.1, 1.15, 1.2, 1.25) $\times I_n$ (8 steps)
- The breaker is tripped above 100 % of $[I_r]$.

Time delay setting

L type

- Standard operating time (sec) is based on the time of 600 % $\times [I_r]$ with inverse time operation.
- Setting range: 0.5, 1.25, 2, 2.5, 5, 10, 15, 20, 25, 30 sec (10 steps)
- The breaker is tripped at ± 15 % of setting time.

S type

- Standard operating time (sec) is based on the time of 120 % $\times [I_r]$ with inverse time operation.
- Setting range: 10, 15, 20, 25, 30, 35, 40, 50, 60 sec (9 steps)
- The breaker is tripped at ± 15 % of setting time.

Short time delay (STD)

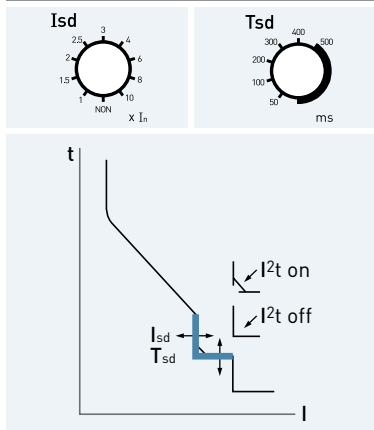

Standard current setting

L type

- The scale is marked as magnification of $[I_n]$.
- Setting range: (Non, 1, 1.5, 2, 2.5, 3, 4, 6, 8, 10) $\times I_n$ (10 steps)

S type

- The scale is marked as magnification of $[I_n]$.
- Setting range: (Non, 1, 1.5, 2, 2.5, 3, 3.5, 4, 4.5, 5) $\times I_n$ (10 steps)

Time delay setting

L type

- Standard operating time (msec) is based on the time of 110 % $\times [I_{sd}]$ with definite time operation.
- Setting range: 50, 100, 200, 300, 400, 500 msec (6 steps)
- 1,000 % of inverse time curve applied in case of inverse time (I^2t on) setting.

S type

- Standard operating time (msec) is based on the time of 110 % $\times [I_{sd}]$ with definite time operation.
- The range of set time is 50, 100, 200, 300, 400, 500 msec (6 steps).
- 500 % of inverse time curve applied in case of inverse time (I^2t on) setting.

Instantaneous trip (INST)

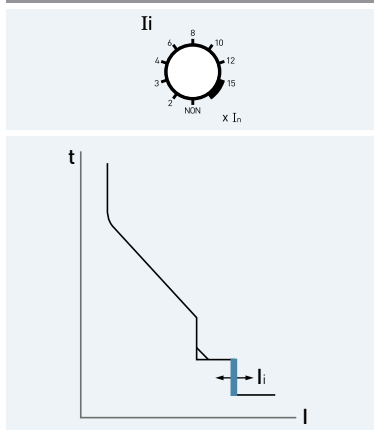

Standard current setting

- The scale is marked as magnification of $[I_n]$.
- Setting range: (Non, 2, 3, 4, 6, 8, 10, 12, 15) $\times I_n$ (9 steps)
- No protection in case of $[I_i]$ is set to Non.

Time delay setting

- Total breaking time is below 50ms.

Protection Trip Relay (OCR)

Operation characteristics

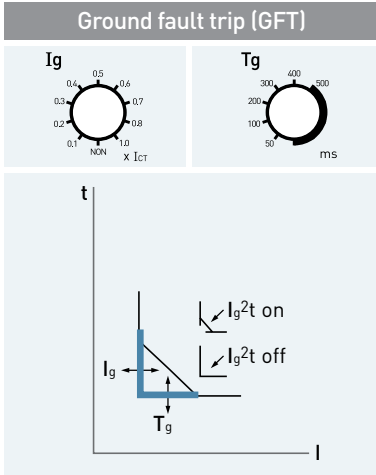

Standard current setting

- **L type**
 - The scale is marked as magnification of OCR rated primary current [Ict].
 - Setting range: (Non, 0.1, 0.2, 0.3, 0.4, 0.5, 0.6, 0.7, 0.8, 1.0) × [Ict] (10 steps)

Time delay setting

- **L type**
 - Standard operating time (msec) is based on the time of 120 % × [Ig] with definite time operation.
 - Setting range: 50, 100, 200, 300, 400, 500 msec (6 steps)
 - Inverse time operated with 100 % of [Ict] standard in case of [I²t on] setting.
 - The breaker is tripped at ±15 % of setting time.

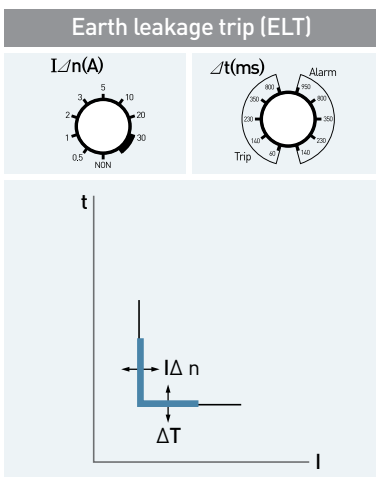

Standard current setting

- **UPR LAZ**
 - This setting value is indicated primary current.
 - The range of value is 9 steps Non, 0.5, 1, 2, 3, 5, 10, 20, 30 (A)
- **UPR LAG**
 - This setting value is indicated secondary current of ZCT.
 - The range of value is 7 steps Non, 0.5, 0.8, 1, 2, 3, 5 (A).

Time delay setting

- **L type**
 - Settings within its alarm range will prevent its breaker from tripping but activating its alarm.
 - Trip time: 60, 140, 230, 350, 800 msec (5 steps)
 - Alarm time: 140, 230, 350, 800, 950 msec (5 steps)

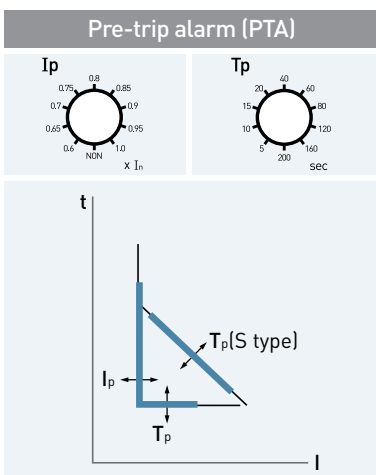

Standard current setting

- **L type**
 - The scale is marked as magnification of [In] with definite time operation.
 - Setting range: (Non, 0.6, 0.65, 0.7, 0.75, 0.8, 0.85, 0.9, 0.95, 1.0) × In (10 steps)
- **S type**
 - The scale is marked as magnification of [In] with inverse time operation.
 - Setting range: (Non, 0.7, 0.75, 0.8, 0.85, 0.9, 0.95, 1.0, 1.05, 1.1) × In (10 steps)

Time delay setting

- **L type**
 - Standard operating time (sec) is based on the time of 100 % × [Ip].
 - Setting range: 5, 10, 15, 20, 40, 60, 80, 120, 160, 200 sec (10 steps)
- **S type**
 - Standard operating time (sec) is based on the time of 120 % × [Ip].
 - Setting range: 1, 5, 10, 15, 20, 25, 30, 35, 40 sec (9 steps)

| Characteristic curves |

General feeder

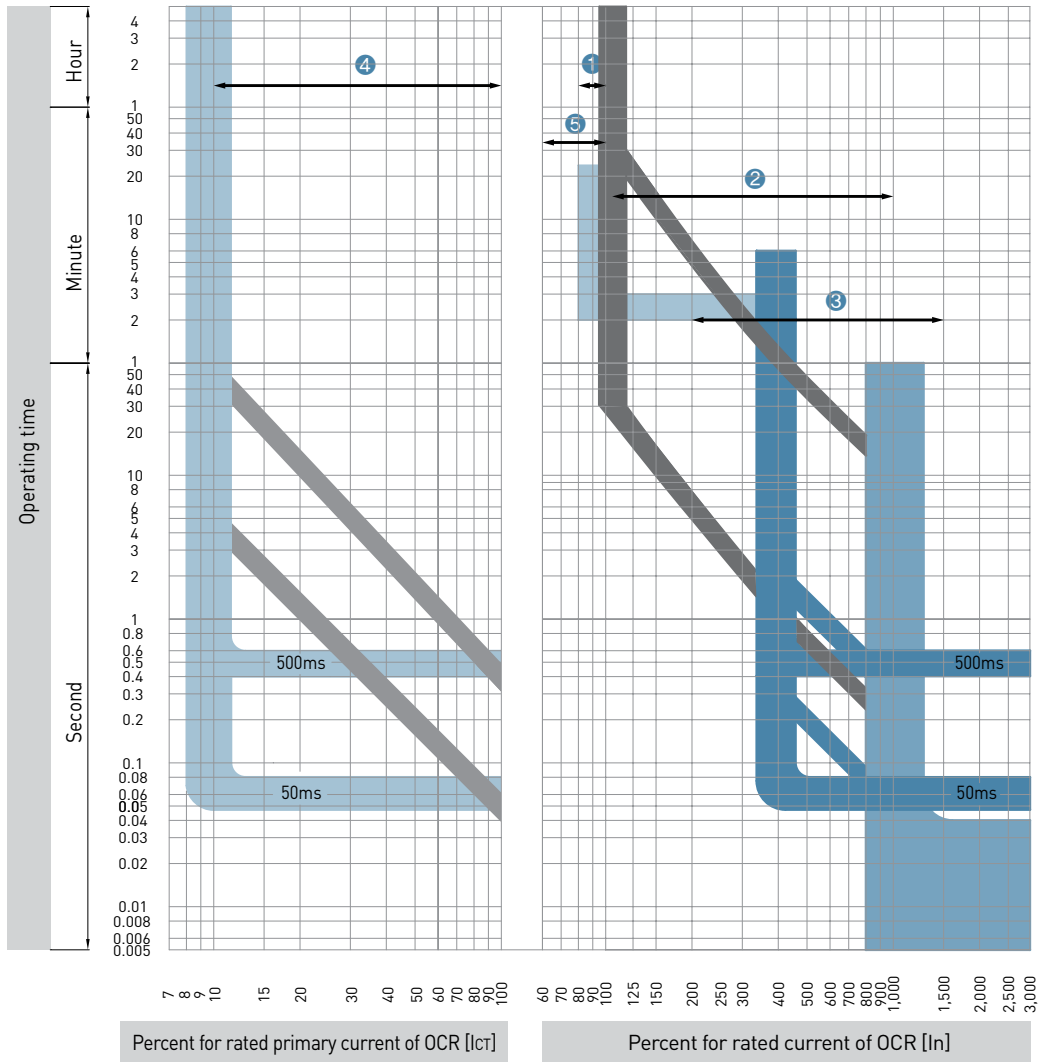

- ① Long time delay current setting range
- ② Short time delay current setting range
- ③ Instantaneous tripping current setting range
- ④ Ground fault trip current setting range
- ⑤ Pre-trip alarm current setting range

Protection Trip Relay (OCR)

| Characteristic curves |

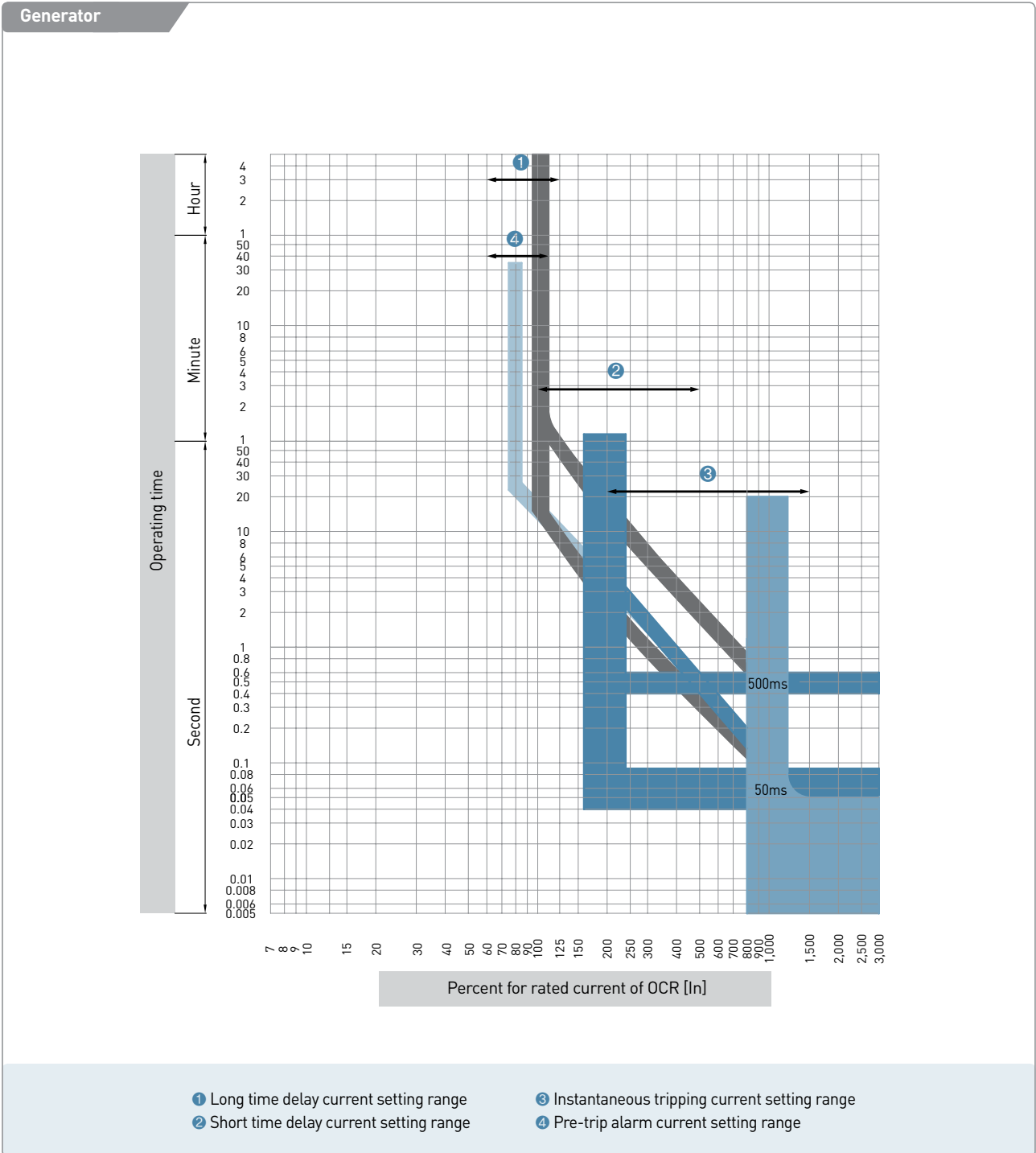

| Measurement |

■ Outside view

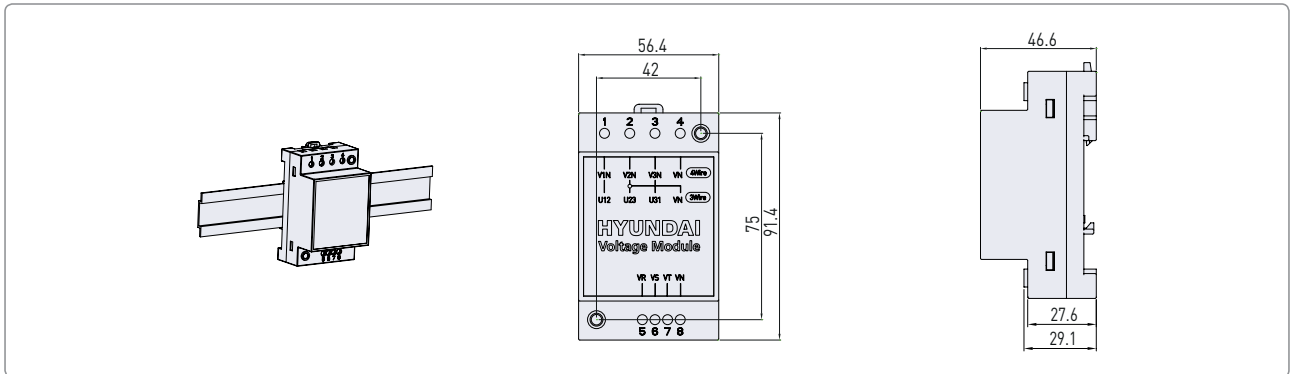

■ Voltage module

- UPR-LP/LH/SP trip relay offers VM (voltage module) as an essential option, to measure voltage.
- Voltage input range: AC69 - 690V

Voltage connection

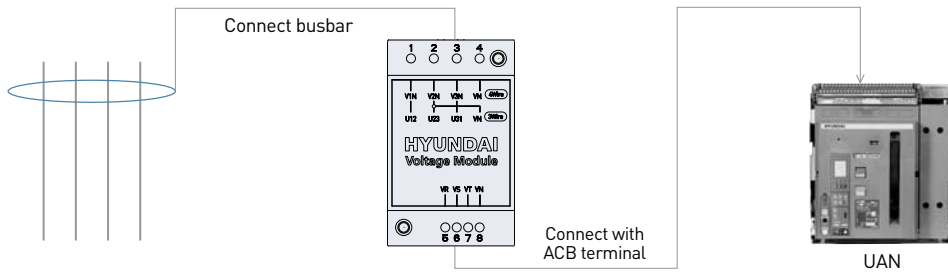

※ Install the length of connecting cable between ACB and voltage module is less than 50mm.

3 P 3 Wire

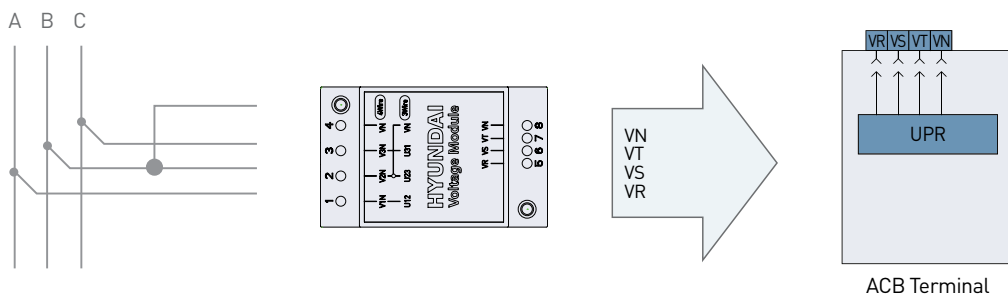

4 P 4 Wire / 3 P 4 Wire

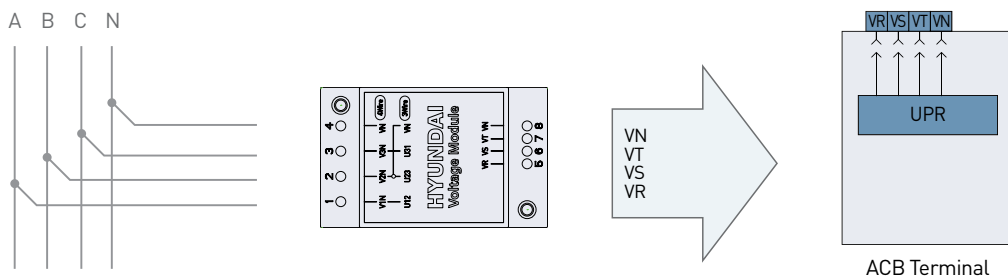

Protection Trip Relay (OCR)

| Zone selective interlock function |

Zone selective interlocking drops delay time that eliminates faults for breakers. It minimizes the shock that all kinds of electric machineries get under fault conditions.

■ Example

- 1 In case of that short time-delay or ground fault accident occurs at ZSI built in system, the breaker at accident site sends ZSI signal to halt upstream breaker's operation.
- 2 To eliminate a breakdown, trip relay of ACB at accident site activates trip operation without time delay.
- 3 The upstream breaker that received ZSI signal adhere to pre-set short time-delay or ground fault time delay for protective coordination in the system. However upstream breaker that did not receive its signal will trip instantaneously.
- 4 For ordinary ZSI operation, it should arrange operation time accordingly so that downstream circuit breakers will react before upstream ones under overcurrent/short time delay/ground fault situations.
- 5 ZSI connecting line needs to be maximum 3m.

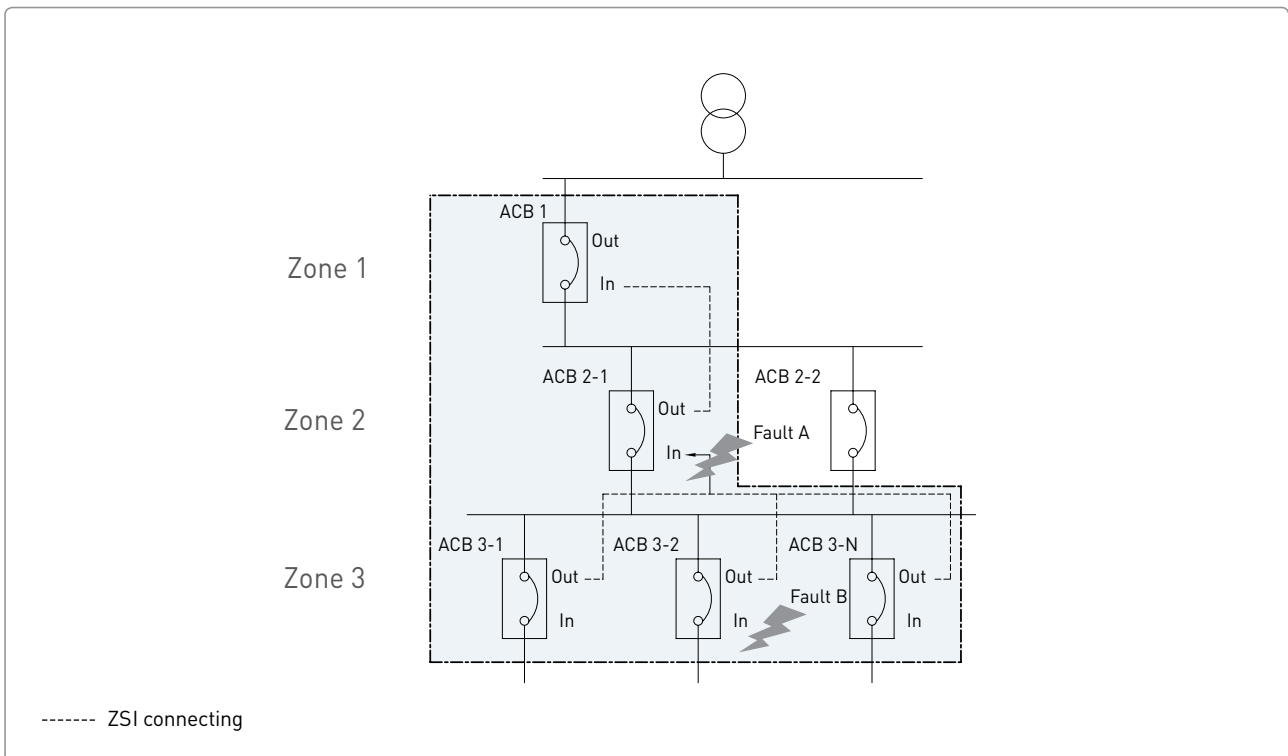

※ It is not available in self-power OCR.

| System diagram |

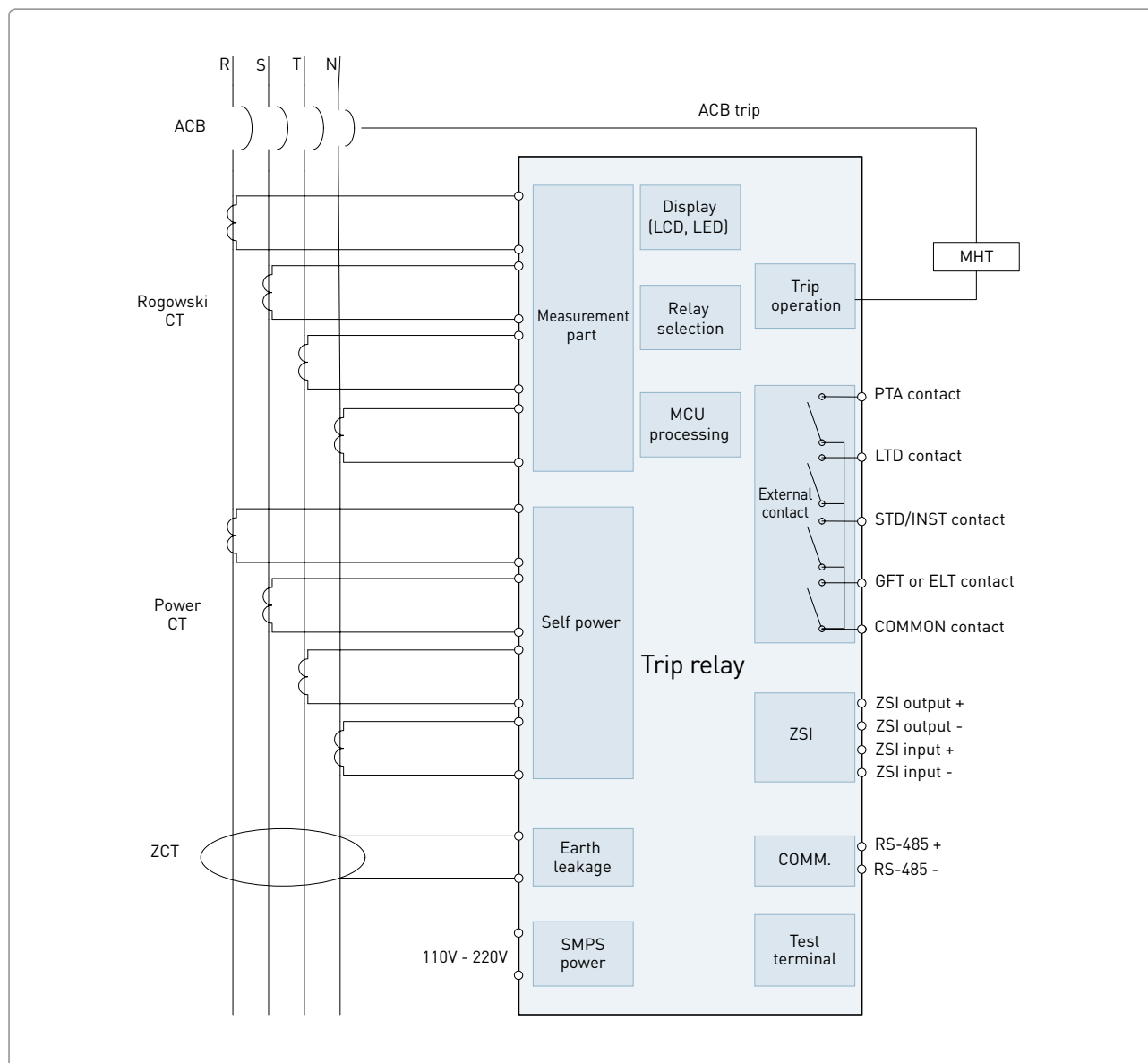

| Communication function |

■ Modbus-RTU / RS-485

- Operation mode: Differential
- Distance: Max. 1.2km
- Cable: RS-485 shielded twist 2-pair cable
- Baud rate: 9,600, 19,200, 38,400 bps
- Transmission method: Half-duplex
- Termination: 150 Ω

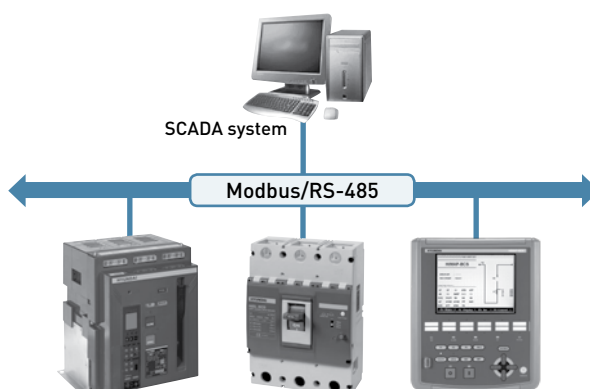

Protection Trip Relay (OCR)

| Circuit diagrams |

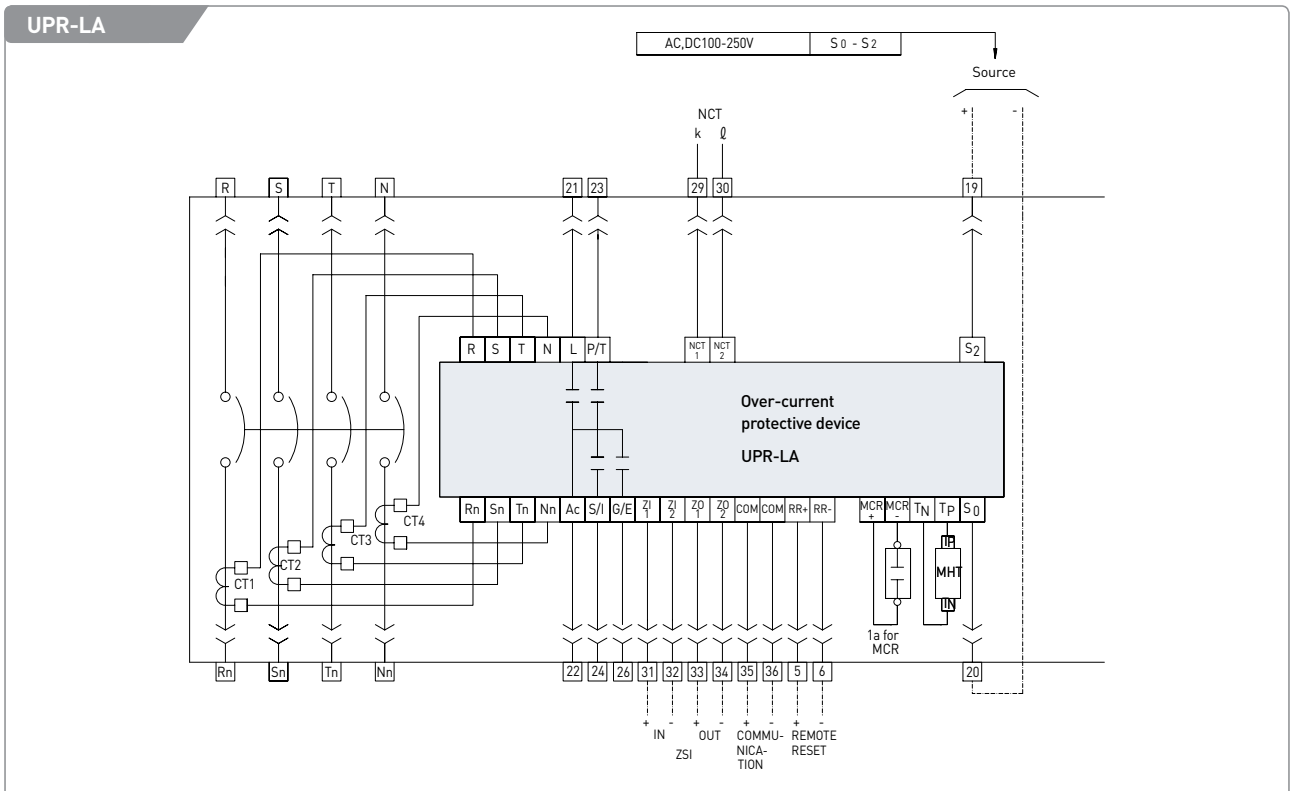
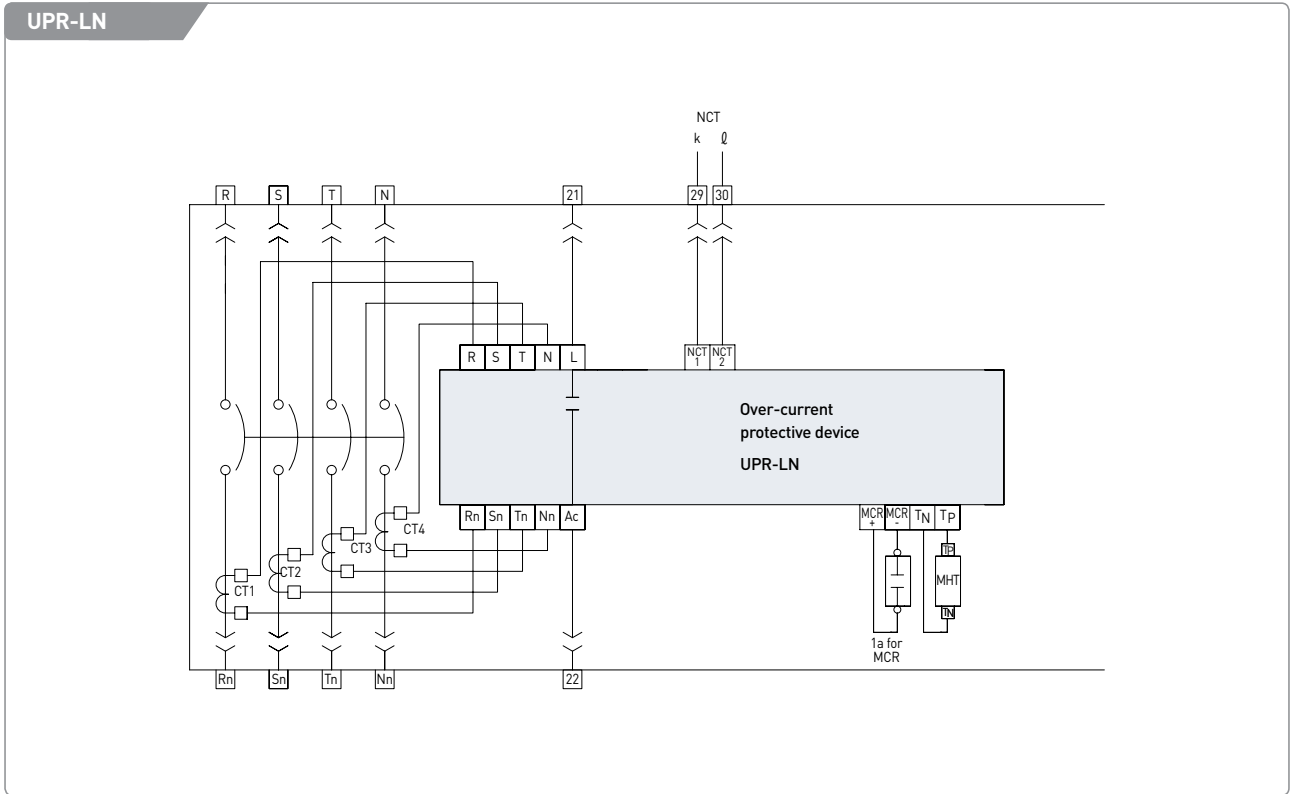

UPR-LAG/LAZ

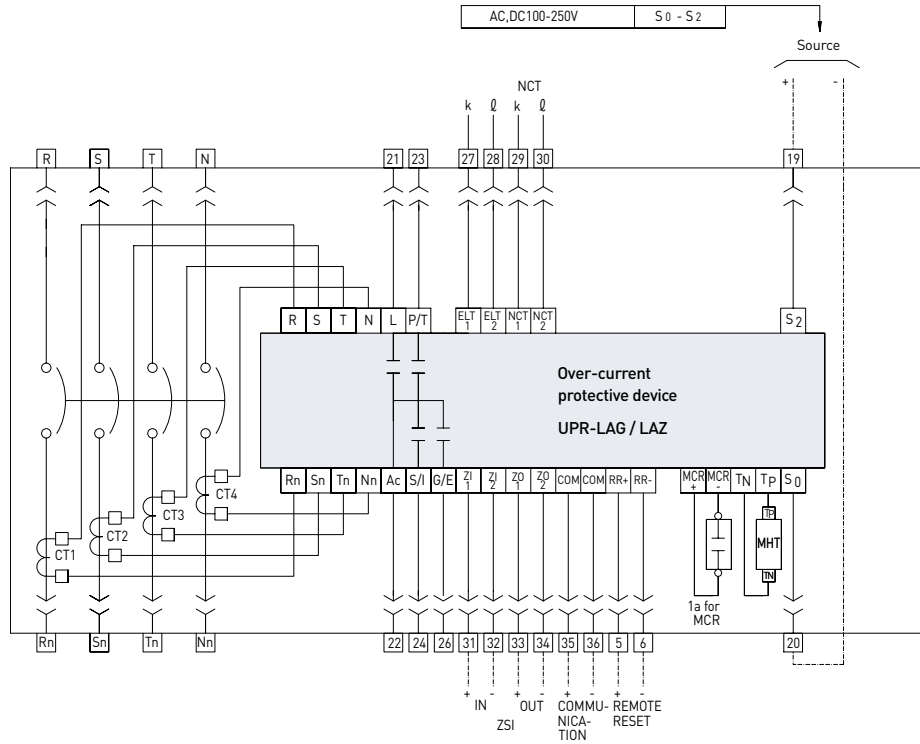

UPR-LP/LH

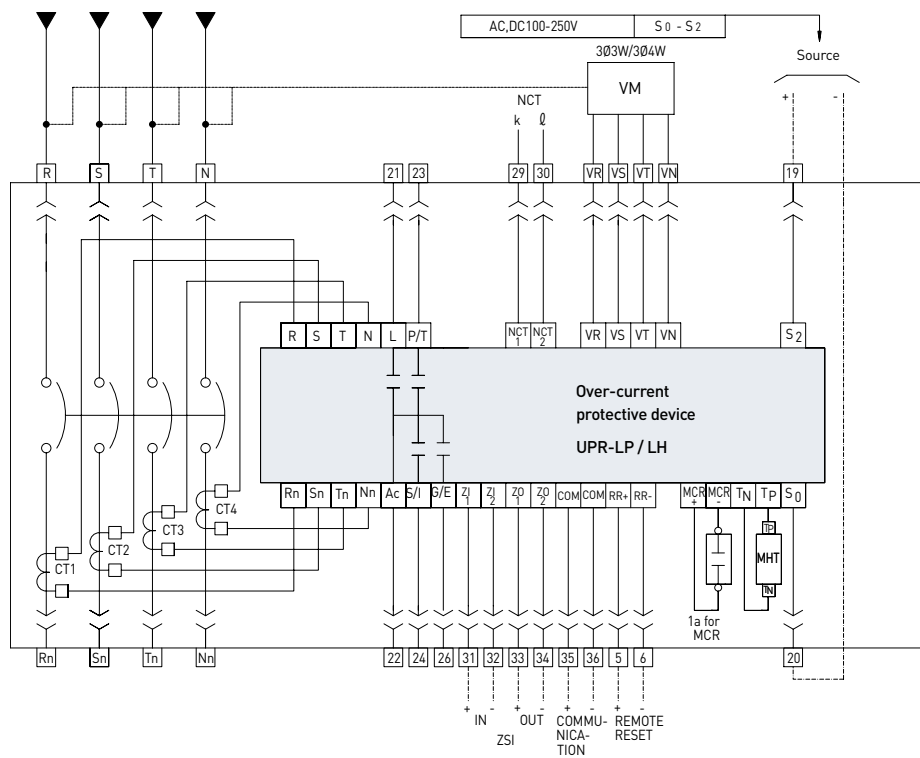

Protection Trip Relay (OCR)

| Circuit diagrams |

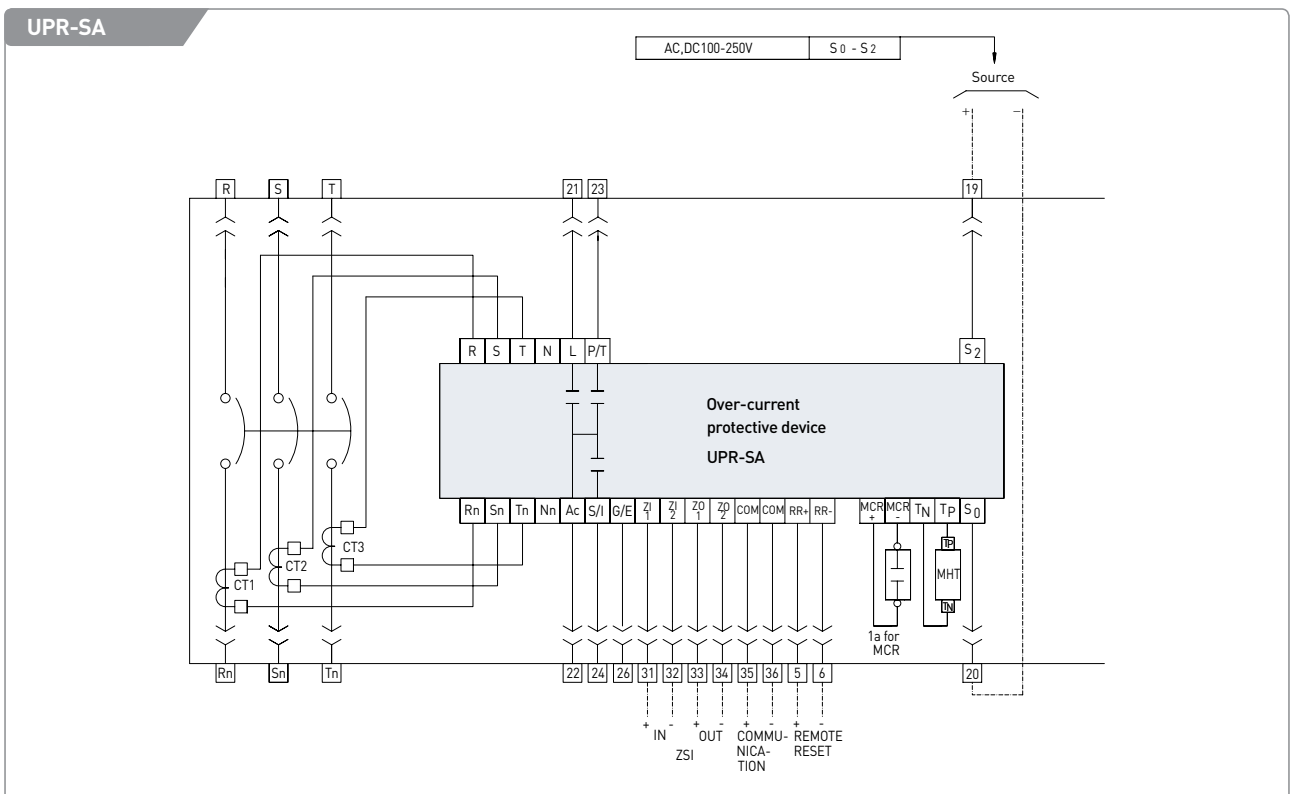
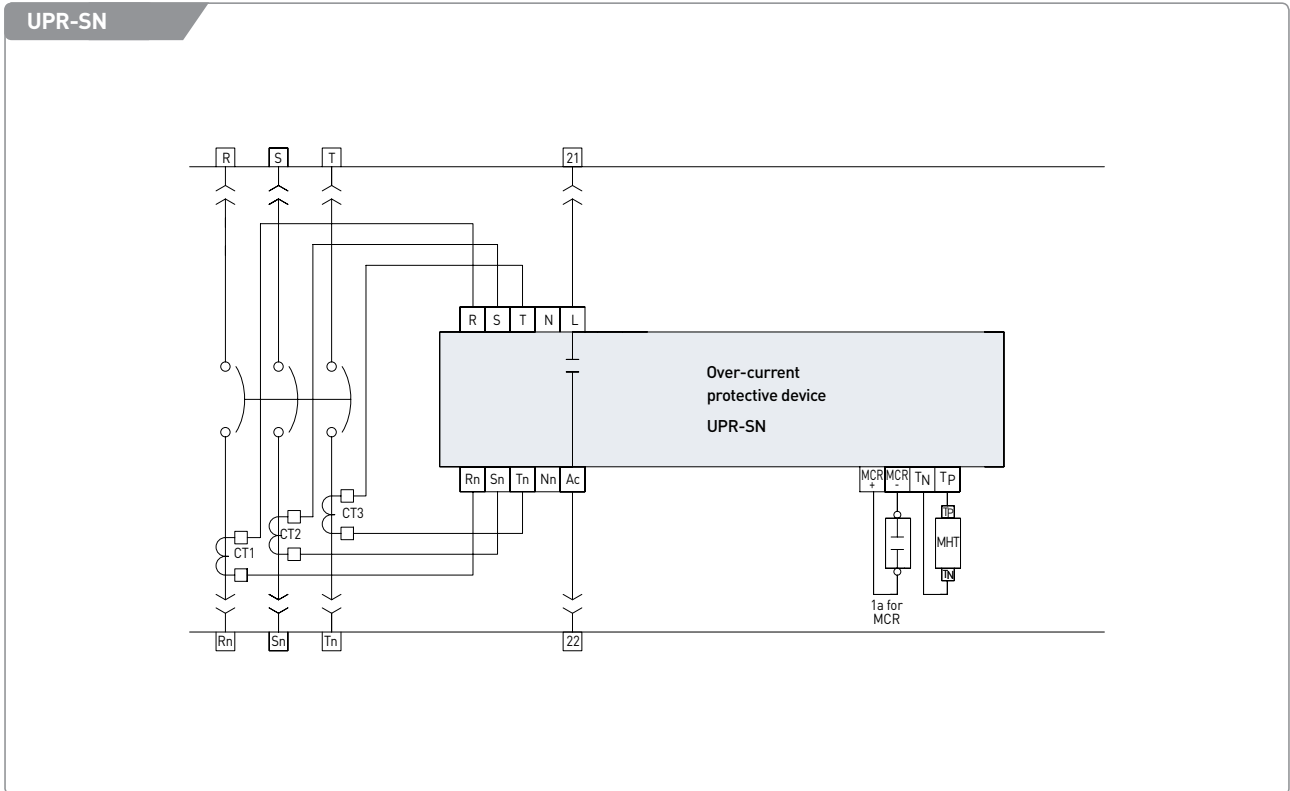

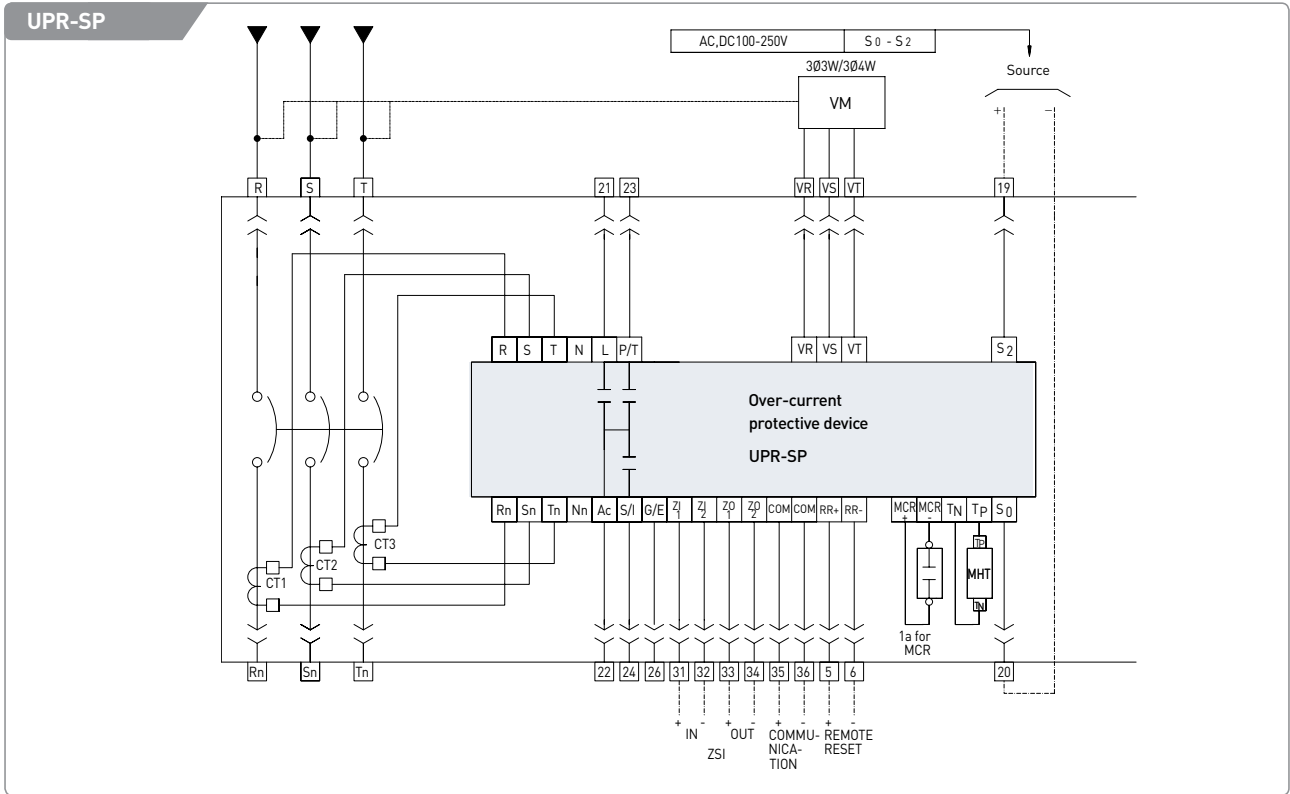

Accessories

Overview

Item	Ordering codes		Specifications	Type of shipment	Page
	Attached	Order separately			
Terminal ¹⁾ (Draw-out type)	-	UANS HVA3	Horizontal type of upper and lower sides/ Vertical type of upper and lower sides (A frame, 06 - 16A 3P)	Separately order	-
	-	UANS HVA4	Horizontal type of upper and lower sides/ Vertical type of upper and lower sides (A frame, 06 - 16A 4P)		
	-	UANS HVB3	Horizontal type of upper and lower sides/ Vertical type of upper and lower sides (B frame, 06 - 32B 3P)		
	-	UANS HVB4	Horizontal type of upper and lower sides Vertical type of upper and lower sides (B frame, 06 - 32B 4P)		
	-	UANS FRA3	Front type of upper and lower sides 6ea (A frame, 06 - 16A 3P)		
	-	UANS FRA4	Front type of upper and lower sides 8ea (A frame, 06 - 16A 4P)		
	-	UANS FRB3	Front type of upper and lower sides 6ea (B frame, 06 - 32B 3P)		
	-	UANS FRB4	Front type of upper and lower sides 8ea (B frame, 06 - 32B 4P)		
	-	UANS FHVA3	Front type of upper and lower sides 3ea + Vertical/ Horizontal type 3ea (A frame 06 - 16A 3P)		
	-	UANS FHVA4	Front type of upper and lower sides 4ea + Vertical/ Horizontal type 4ea (A frame 06 - 16A 4P)		
	-	UANS FHVB3	Front type of upper and lower sides 3ea + Vertical/ Horizontal type 3ea 06 - 32B 3P		
	-	UANS FHVB4	Front type of upper and lower sides 4ea + Vertical/ Horizontal type 4ea 06 - 32B 4P		
Terminal ²⁾ (Fix type)	-	UANS FRA3F	Front type of upper and lower sides 6ea (A frame, 06 - 16A 3P) + Additional spacer 6	Separately order	-
	-	UANS FRA4F	Front type of upper and lower sides 8ea (A frame, 06 - 16A 4P) + Additional spacer 8		
	-	UANS FRB3F	Front type of upper and lower sides 6ea (B frame, 06 - 32B 3P) + Additional spacer 6		
	-	UANS FRB4F	Front type of upper and lower sides 8ea (B frame, 06 - 32B 4P) + Additional spacer 8		
	-	UANS FHVA3F	Front type of upper and lower sides 3ea + Vertical/ Horizontal type 3ea 06 - 16A 3P + Additional spacer 3		
	-	UANS FHVA4F	Front type of upper and lower sides 4ea + Vertical/ Horizontal type 4ea 06 - 16A 4P + Additional spacer 4		
	-	UANS FHVB3F	Front type of upper and lower sides 3ea + Vertical/ Horizontal type 3ea 06 - 32B 3P + Additional spacer 3		
	-	UANS FHVB4F	Front type of upper and lower sides 4ea + Vertical/ Horizontal type 4ea 06 - 32B 4P + Additional spacer 4		
Auxiliary switch ³⁾	-	UANS A3A	Auxiliary switch for auto connection type 3a + 3b	Separately order	-
	-	UANS A3J	Auxiliary switch for manual connection type 3a + 3b		
	A5 (UAS)	UANS A5A	Auxiliary switch for auto connection type 5a + 5b		
	A5 (UAS)	UANS A5J	Auxiliary switch for manual connection type 5a + 5b		
	AA	UANS AA-A/C	Additional auxiliary switch 1a1b (Max : 6a6b) - A/C frame	Attached/ Separately order	-
	AA	UANS AA-B/D	Additional auxiliary switch 1a1b (Max: 6a6b) - B/D frame		
	MC	UANS MOC	External extension auxiliary switch 10a10b (Mechanical opening cell switch)		
Counter	-	UANS AD	Counter (standard)	Separately order	-
Body auto connector	A	UANS ACA5	Body autoconnection + Auxiliary switch 5a + 5b + Control wire	Separately order	-
	A	UANS ACA3	Body autoconnection + Auxiliary switch 3a + 3b + Control wire		
Auto connector jack	A	UANS ACJ	Autoconnection control jack for cradle		
Control terminal protection cover	BC	UANS BC	Control protection cover for auto connection type (Fix type, manual type is not used)	Attached/ Separately order	-
Manual connector	J	UANS MCJ	Manual control plug	Separately order	-
Manual connector lead wire	J	UANS MWIRE	Manual control lead wire	Attached/ Separately order	-

Item	Ordering codes		Specifications	Type of shipment	Page
	Attached	Order separately			
Motor unit ⁴⁾	M1	UANS M1U	AC/DC110V motor + MCU + Ratchet M + Ratchet B + Spring + Bolt	Attached/ Separately order	-
	M2	UANS M2U	AC/DC220V motor + MCU + Ratchet M + Ratchet B + Spring + Bolt		
	M3	UANS M3U	AC380V motor + MCU + Ratchet M + Ratchet B + Spring + Bolt		
	M4	UANS M4U	AC440V motor + MCU + Ratchet M + Ratchet B + Spring + Bolt		
	M7	UANS M7U	DC24V motor + MCU + Ratchet M + Ratchet B + Spring + Bolt		
	M8	UANS M8U	DC48V motor + MCU + Ratchet M + Ratchet B + Spring + Bolt		
	M9	UANS M9U	DC125V motor + MCU + Ratchet M + Ratchet B + Spring + Bolt		
Motor acce	-	UANS MCU	Motor controller unit only	Separately order	-
	-	UANS MSW	Motor on/off switch only		
Spring charge switch	B6	UANS B6	DO Contact "1a"	Attached/ Separately order	
Closing coil	C1	UANS C1	AC/DC110V	Attached/ Separately order	-
	C2	UANS C2	AC/DC220V		
	C3	UANS C3	AC380V		
	C4	UANS C4	AC440V		
	C7	UANS C7	DC24V		
	C8	UANS C8	DC48V		
	C9	UANS C9	DC125V		
Trip coil	S1	UANS S1	AC/DC110V	Attached/ Separately order	-
	S2	UANS S2	AC/DC220V		
	S3	UANS S3	AC380V		
	S4	UANS S4	AC440V		
	S7	UANS S7	DC24V		
	S8	UANS S8	DC48V		
	S9	UANS S9	DC125V		
Condenser trip device	-	UANS CTD1	AC/DC110V	Separately order	-
	-	UANS CTD2	AC/DC220V		
Trip coil supervision	T1	UANS T1	AC/DC110V	Attached/ Separately order	-
	T2	UANS T2	AC/DC220V		
	T3	UANS T3	AC380V		
	T4	UANS T4	AC440V		
	T7	UANS T7	DC24V		
	T8	UANS T8	DC48V		
	T9	UANS T9	DC125V		
Secondary trip coil	S1	UANS SS1	AC/DC110V	Attached/ Separately order	-
	S2	UANS SS2	AC/DC220V		
	S3	UANS SS3	AC380V		
	S4	UANS SS4	AC440V		
	S7	UANS SS7	DC24V		
	S8	UANS SS8	DC48V		
	S9	UANS SS9	DC125V		
UVT coil (Instantaneous type)	U1	UANS U1	AC/DC110V	Attached/ Separately order	-
	U2	UANS U2	AC/DC220V		
	U3	UANS U3	AC380V		
	U4	UANS U4	AC440V		
	U7	UANS U7	DC24V		
	U8	UANS U8	DC48V		
	U9	UANS U9	DC125V		

Accessories

| Overview |

Item	Ordering codes		Specifications	Type of shipment	Page
	Attached	Order separately			
UVT time delay modul ⁵⁾	-	UANS UT1	AC/DC110V & DC125V	Separately order	-
	-	UANS UT2	AC/DC220V		
	-	UANS UT3	AC380V		
	-	UANS UT4	AC440V		
	-	UANS UT9	AC/DC110V & DC125V		
UVT time delay modul + UVT coil	V1	UANS V1	AC/DC110V	Attached/ Separately order	-
	V2	UANS V2	AC/DC220V		
	V3	UANS V3	AC380V		
	V4	UANS V4	AC440V		
	V9	UANS V9	DC125V		
OCR ⁶⁾	50/60	UANS OCR-LN (50/60) A U	OCR UPR-LN (50/60) unit autoconnection + MHT	Attached/ Separately order	-
		UANS OCR-LN (50/60) J U	OCR UPR-LN (50/60) unit manual jack (fixed type) + MHT		
		UANS OCR-LN (50/60) A	OCR UPR-LN (50/60) unit autoconnection		
		UANS OCR-LN (50/60) J	OCR UPR-LN (50/60) unit manual jack (fixed type)		
		UANS OCR-LN (50/60)	OCR UPR-LN (50/60) only		
	51/61	UANS OCR-LA (51/61) A U	OCR UPR-LA (51/61) unit autoconnection + MHT	Attached/ Separately order	-
		UANS OCR-LA (51/61) J U	OCR UPR-LA (51/61) unit manual jack (fixed type) + MHT		
		UANS OCR-LA (51/61) A	OCR UPR-LA (51/61) unit autoconnection		
		UANS OCR-LA (51/61) J	OCR UPR-LA (51/61) unit manual jack (fixed type)		
		UANS OCR-LA (51/61)	OCR UPR-LA (51/61) only		
	52/62	UANS OCR-LAG (52/62) A U	OCR UPR-LAG (52/62) unit autoconnection + MHT	Attached/ Separately order	-
		UANS OCR-LAG (52/62) J U	OCR UPR-LAG (52/62) unit manual jack (fixed type) + MHT		
		UANS OCR-LAG (52/62) A	OCR UPR-LAG (52/62) unit autoconnection		
		UANS OCR-LAG (52/62) J	OCR UPR-LAG (52/62) unit manual jack (fixed type)		
		UANS OCR-LAG (52/62)	OCR UPR-LAG (52/62) only		
	53/63	UANS OCR-LAZ (53/63) A U	OCR UPR-LAZ (53/63) unit autoconnection + MHT	Attached/ Separately order	-
		UANS OCR-LAZ (53/63) J U	OCR UPR-LAZ (53/63) unit manual jack (fixed type) + MHT		
		UANS OCR-LAZ (53/63) A	OCR UPR-LAZ (53/63) unit autoconnection		
		UANS OCR-LAZ (53/63) J	OCR UPR-LAZ (53/63) unit manual jack (fixed type)		
		UANS OCR-LAZ (53/63)	OCR UPR-LAZ (53/63) only		
54/64	UANS OCR-LP (54/64) A U	OCR UPR-LP (54/64) unit autoconnection & Voltage module + MHT	Attached/ Separately order	-	
	UANS OCR-LP (54/64) J U	OCR UPR-LP (54/64) unit manual jack (fixed type) & Voltage module + MHT			
	UANS OCR-LP (54/64) A	OCR UPR-LP (54/64) unit autoconnection & Voltage module			
	UANS OCR-LP (54/64) J	OCR UPR-LP (54/64) unit manual jack (fixed type) & Voltage module			
	UANS OCR-LP (54/64)	OCR UPR-LP (54/64) only			

Item	Ordering codes		Specifications	Type of shipment	Page
	Attached	Order separately			
OCR ^{sl}	55/65	UANS OCR-LH (55/65) A U	OCR UPR-LH (55/65) unit autoconnection & Voltage module + MHT	Attached/ Separately order	-
		UANS OCR-LH (55/65) J U	OCR UPR-LH (55/65) unit manual jack (fixed type) & Voltage module + MHT		
		UANS OCR-LH (55/65) A	OCR UPR-LH (55/65) unit autoconnection & Voltage module		
		UANS OCR-LH (55/65) J	OCR UPR-LH(55/65) unit manual jack (fixed type) & Voltage module		
		UANS OCR-LH (55/65)	OCR UPR-LH(55/65) only		
	57/67	UANS OCR-SN (57/67) A U	OCR UPR-SN (57/67) unit autoconnection + MHT	Attached/ Separately order	-
		UANS OCR-SN (57/67) J U	OCR UPR-SN (57/67) unit manual jack (fixed type) + MHT		
		UANS OCR-SN (57/67) A	OCR UPR-SN (57/67) unit autoconnection		
		UANS OCR-SN (57/67) J	OCR UPR-SN (57/67) unit manual jack (fixed type)		
		UANS OCR-SN (57/67)	OCR UPR-SN (57/67) only		
	58/68	UANS OCR-SA (58/68) A U	OCR UPR-SA (58/68) unit autoconnection + MHT	Attached/ Separately order	-
		UANS OCR-SA (58/68) J U	OCR UPR-SA (58/68) unit manual jack (fixed type) + MHT		
		UANS OCR-SA (58/68) A	OCR UPR-SA (58/68) unit autoconnection		
		UANS OCR-SA (58/68) J	OCR UPR-SA (58/68) unit manual jack (fixed type)		
		UANS OCR-SA (58/68)	OCR UPR-SA (58/68) only		
	59/69	UANS OCR-SP (59/69) A U	OCR UPR-SP (59/69) unit autoconnection & Voltage module + MHT	Attached/ Separately order	-
		UANS OCR-SP (59/69) J U	OCR UPR-SP (59/69) unit manual jack (fixed type) & Voltage module + MHT		
		UANS OCR-SP (59/69) A	OCR UPR-SP (59/69) unit autoconnection & Voltage module		
		UANS OCR-SP (59/69) J	OCR UPR-SP (59/69) unit manual jack (fixed type) & Voltage module		
		UANS OCR-SP (59/69)	OCR UPR-SP (59/69) only		
OCR ACCE	-	UANS OC	OCR portable checker	Separately order	-
	-	UANS VM	Voltage module	Separately order	-
	B8	UANS MCR	OCR MCR wire	Attached/ Separately order	-
	-	UANS MHT	MHT (magnetic holding trigger) coil only	Separately order	-
	BR	UANS BR	OCR Manual reset (interlock manual reset) & BR MHT (no alarm contact)	Attached/ Separately order	-
	BA	UANS BA	OCR Manual reset (interlock manual reset + Alarm switch reset 2a)		
	BH	UANS BH	OCR Manual reset (interlock manual reset + Alarm switch reset high capacity 1a)	Separately order	-
	-	UANS OCR00COV	OCR 00 cover		
-	UANS MRB	Interlock manual reset button	Separately order	-	
CT package	O	UANS CTA03	A frame O = 200A 3P set + Lead wire	Attached/ Separately order	-
	O	UANS CTA04	A frame O = 200A 4P set + Lead wire		
	V	UANS CTAV3	A frame V = 320A 3P set + Lead wire		
	V	UANS CTAV4	A frame V = 320A 4P set + Lead wire		
	E	UANS CTAE3	A frame E = 400A 3P set + Lead wire		
	E	UANS CTAE4	A frame E = 400A 4P set + Lead wire		

Accessories

| Overview |

Item	Ordering codes		Specifications	Type of shipment	Page
	Attached	Order separately			
CT package	T	UANS CTAT3	A frame T = 630A 3P set + Lead wire	Attached/ Separately order	-
	T	UANS CTAT4	A frame T = 630A 4P set + Lead wire		
	H	UANS CTAH3	A frame H = 800A 3P set + Lead wire		
	H	UANS CTAH4	A frame H = 800A 4P set + Lead wire		
	J	UANS CTAJ3	A frame J = 1,000A 3P set + Lead wire		
	J	UANS CTAJ4	A frame J = 1,000A 4P set + Lead wire		
	K	UANS CTAK3	A frame K = 1,250A 3P set + Lead wire		
	K	UANS CTAK4	A frame K = 1,250A 4P set + Lead wire		
	L	UANS CTAL3	A frame L = 1,600A 3P set + Lead wire		
	L	UANS CTAL4	A frame L = 1,600A 4P set + Lead wire		
	M	UANS CTAM3	A frame M = 2,000A 3P set + Lead wire		
	M	UANS CTAM4	A frame M = 2,000A 4P set + Lead wire		
	E	UANS CTBE3	B frame E = 400A 3P set + Lead wire		
	E	UANS CTBE4	B frame E = 400A 4P set + Lead wire		
	T	UANS CTBT3	B frame T = 630A 3P set + Lead wire		
	T	UANS CTBT4	B frame T = 630A 4P set + Lead wire		
	H	UANS CTBH3	B frame H = 800A 3P set + Lead wire		
	H	UANS CTBH4	B frame H = 800A 4P set + Lead wire		
	J	UANS CTBJ3	B frame J = 1,000A 3P set + Lead wire		
	J	UANS CTBJ4	B frame J = 1,000A 4P set + Lead wire		
	K	UANS CTBK3	B frame K = 1,250A 3P set + Lead wire		
	K	UANS CTBK4	B frame K = 1,250A 4P set + Lead wire		
	L	UANS CTBL3	B frame L = 1,600A 3P set + Lead wire		
	L	UANS CTBL4	B frame L = 1,600A 4P set + Lead wire		
	M	UANS CTBM3	B frame M = 2,000A 3P set + Lead wire		
	M	UANS CTBM4	B frame M = 2,000A 4P set + Lead wire		
	N	UANS CTBN3	B frame N = 2,500A 3P set + Lead wire		
	N	UANS CTBN4	B frame N = 2,500A 4P set + Lead wire		
	P	UANS CTBP3	B frame P = 3,200A 3P set + Lead wire		
	P	UANS CTBP4	B frame P = 3,200A 4P set + Lead wire		
	Q	UANS CTBQ3	B frame Q = 4,000A 3P set + Lead wire		
	Q	UANS CTBQ4	B frame Q = 4,000A 4P set + Lead wire		
	P	UANS CTCP3	C frame P = 3,200A 3P set + Lead wire		
	P	UANS CTCP4	C frame P = 3,200A 4P set + Lead wire		
	Q	UANS CTCQ3	C frame Q = 4,000A 3P set + Lead wire		
	Q	UANS CTCQ4	C frame Q = 4,000A 4P set + Lead wire		
	S	UANS CTCS3	C frame S = 5,000A 3P set + Lead wire		
	S	UANS CTCS4	C frame S = 5,000A 4P set + Lead wire		
	Q	UANS CTDQ3	D frame Q = 4,000A 3P set + Lead wire		
	Q	UANS CTDQ4	D frame Q = 4,000A 4P set + Lead wire		
S	UANS CTDS3	D frame S = 5,000A 3P set + Lead wire			
S	UANS CTDS4	D frame S = 5,000A 4P set + Lead wire			
X	UANS CTDX3	D frame X = 6,300A 3P set + Lead wire			
X	UANS CTDX4	D frame X = 6,300A 4P set + Lead wire			

Item	Ordering codes		Specifications	Type of shipment	Page
	Attached	Order separately			
CT only	O	UANS CTAO	A frame O = 200A CT only	Separately order	-
	V	UANS CTAV	A frame V = 320A CT only		
	E	UANS CTAE	A frame E = 400A CT only		
	T	UANS CTAT	A frame T = 630A CT only		
	H	UANS CTAH	A frame H = 800A CT only		
	J	UANS CTAJ	A frame J = 1,000A CT only		
	K	UANS CTAK	A frame K = 1,250A CT only		
	L	UANS CTAL	A frame L = 1,600A CT only		
	M	UANS CTAM	A frame M = 2,000A CT only		
	E	UANS CTBE	B frame E = 400A CT only		
	T	UANS CTBT	B frame T = 630A CT only		
	H	UANS CTBH	B frame H = 800A CT only		
	J	UANS CTBJ	B frame J = 1,000A CT only		
	K	UANS CTBK	B frame K = 1,250A CT only		
	L	UANS CTBL	B frame L = 1,600A CT only		
	M	UANS CTBM	B frame M = 2,000A CT only		
	N	UANS CTBN	B frame N = 2,500A CT only		
	P	UANS CTBP	B frame P = 3,200A CT only		
	Q	UANS CTBQ	B frame Q = 4,000A CT only		
	P	UANS CTCP	C frame P = 3,200A CT only		
	Q	UANS CTCQ	C frame Q = 4,000A CT only		
	S	UANS CTC S	C frame S = 5,000A CT only		
	Q	UANS CTDQ	D frame Q = 4,000A CT only		
S	UANS CTDS	D frame S = 5,000A CT only			
X	UANS CTDX	D frame X = 6,300A CT only			
CT lead wire	-	UANS CTW AB3	CT lead wire set A/B frame 3P	Separately order	-
	-	UANS CTW AB4	CT lead wire set A/B frame 4P		
	-	UANS CTW WX4	CT lead wire set W/X frame 4P		
	-	UANS CTW CD3	CT lead wire set C/D frame 3P		
	-	UANS CTW CD4	CT lead wire set C/D frame 4P		
	-	UANS CTW YZ4	CT lead wire set Y/Z frame 4P		
Key lock	AB	UANS AB	Key lock	Attached/ Separately order	-
Safety shutter	AE	UANS AEA3	06A3 - 20A3	Attached/ Separately order	-
		UANS AEA4	06A4 - 20A4		
		UANS AEB3	20B3 - 40B3		
		UANS AEB4	20B4 - 40B4		
		UANS AEC3	32C3 - 50C3		
UANS AEC4	32C4 - 50C4				
Fixing block	AF	UANS AF	ACB main body + Cradle	Attached/ Separately order	-
		UANS AFB	ACB main body + Cradle	Separately order	-
		UANS AFC	Cradle		
Door flange	AG	UANS AG	IP30	Attached/ Separately order	-
Dust cover	-	UANS DC	IP54	Separately order	-
Test jumper	-	UANS AJ	Test jumper for auto-connection type	Separately order	-
Short "B" contact	AK	UANS AK	Short "B" contact	Attached/ Separately order	-

Accessories

Overview

Item	Ordering codes		Specifications	Type of shipment	Page
	Attached	Order separately			
Lifting LUG	-	UANS AL	2ea = 1 set, provision it basically for C frame 5,000A	Separately order	-
ON/OFF button lock	AM	UANS AM	ON/OFF button cover lock	Attached/ Separately order	-
Position switch ⁷⁾	AQ	UANS AQ	Test 1C, connection 1C	Attached/ Separately order	-
	AR	UANS AR	Connection 2C		
	AS	UANS AS	Test 2C		
	AT	UANS AT	Isolation 1C, insertion 1C		
	AU	UANS AU	Insertion 2C		
	AV	UANS AV	Isolation 2C		
	P4	UANS P4	Test 2C, connection 2C		
	PS	UANS PS	Isolation 1C, test 1C, connection 2C		
	PT	UANS PT	Test 4C		
	PQ	UANS PQ	Insertion 1C, isolation 1C, test 1C, connection 1C		
	P8	UANS P8	Insertion 2C, isolation 2C, test 2C, connection 2C		
PR	UANS PR	Insertion 1C, isolation 1C, test 3C, connection 3C			
Mal-insertion protection device	AW	UANS AW	Main body + Cradle, additional main body/ Cradle ordering code separately	Attached/ Separately order	-
Arc shield	AX	UANS AXA3	06A3 - 20A3	Attached/ Separately order	-
		UANS AXA4	06A4 - 20A4		
		UANS AXB3	20B3 - 40B3		
		UANS AXB4	20B4 - 40B4		
		UANS AXC3	32C3 - 50C3		
		UANS AXC4	32C4 - 50C4		
Mech interlock ⁸⁾	-	UANS DWB1	Drawout (Fixed)/wire type 2 way MI	Separately order	-
	-	UANS DWB2	Drawout (Fixed)/wire type 3 way MI		
	-	UANS FWB1	Fixed/wire type 2 way MI		
	-	UANS FWB2	Fixed/wire type 3 way MI		
	-	UANS DWB1A	A frame, draw-out type, wire type 2 way MI + Interlock parts (B0)		
	-	UANS DWB2A	A frame, draw-out type, wire type 3 way MI + Interlock parts (B0)		
	-	UANS DWB1B	B frame, draw-out type, wire type 2 way MI + Interlock parts (B0)		
	-	UANS DWB2B	B frame, draw-out type, wire type 3 way MI + Interlock parts (B0)		
	-	UANS DWB1C3	C frame 3P, draw-out type, wire type 2 way MI + Interlock parts (B0)		
	-	UANS DWB1C4	C frame 4P, draw-out type, wire type 3 way MI + Interlock parts (B0)		
	-	UANS DWB2C3	C frame 3P, draw-out type, wire type 3 way MI + Interlock parts (B0)		
	-	UANS DWB2C4	C frame 4P, draw-out type, wire type 3 way MI + Interlock parts (B0)		
	-	UANS FWB1A	A frame, fix type, wire type 2 way MI + Interlock parts (B0)		
	-	UANS FWB2A	A frame, fix type, wire type 3 way MI + Interlock parts (B0)		
	-	UANS FWB1B	B frame, fix type, wire type 2 way MI + Interlock parts (B0)		
	-	UANS FWB2B	B frame, fix type, wire type 3 way MI + Interlock parts (B0)		
	-	UANS FWB1C3	C frame 3P, fix type, wire type 2 way MI + Interlock parts (B0)		
	-	UANS FWB1C4	C frame 4P, fix type, wire type 2 way MI + Interlock parts (B0)		
	-	UANS FWB2C3	C frame 3P, fix type, wire type 3 way MI + Interlock parts (B0)		
	-	UANS FWB2C4	C frame 4P, fix type, wire type 3 way MI + Interlock parts (B0)		
	B0	UANS B0DA	A frame interlock parts (B0)		
B0	UANS B0DB	B frame interlock parts (B0)			
B0	UANS B0DC3	C frame 3P interlock parts (B0)			
B0	UANS B0DC4	C frame 4P interlock parts (B0)			
B0	UANS B0FA	A frame interlock parts (B0) + Fixed bracket			

Item	Ordering codes		Specifications	Type of shipment	Page
	Attached	Order separately			
Mech interlock [®]	B0	UANS B0FB	B frame interlock parts (B0)+ Fixed bracket	Attached/ Separately order	-
	B0	UANS B0FC3	C frame 3P interlock parts (B0) + Fixed bracket		
	B0	UANS B0FC4	C frame 4P interlock parts (B0) + Fixed bracket		
ATS controller	B6B7	UANS ATS	ATS controller UNIT (ATS controller + 2 way M/I + Wiring assemble) for draw out	Attached/ Separately order	-
RCTU	-	UANS RCU	RCU only	Separately order	-
	-	UANS RCTU	RCU + Temperature function		
	-	UANS RCTUN	RCU + Temperature function + Temperature detecting sensor		
	-	UANS TSN	Temperature detecting sensor only		
Neutral CT	-	UANS NCT_T	T = 630A/Inner diameter 80	Separately order	-
	-	UANS NCT_H	NCT H = 800A/Inner diameter 80		
	-	UANS NCT_J	NCT J = 1,000A/Inner diameter 80		
	-	UANS NCT_K	NCT K = 1,250A/Inner diameter 80		
	-	UANS NCT_L	NCT L = 1,600A/Inner diameter 80		
	-	UANS NCT_M	NCT M = 2,000A/Inner diameter 135		
	-	UANS NCT_N	NCT N = 2,500A/Inner diameter 135		
	-	UANS NCT_P	NCT P = 3,200A/Inner diameter 135		
	-	UANS NCT_Q	NCT Q = 4,000A/Inner diameter 200		
-	UANS NCT_S	NCT S = 5,000A/Inner diameter 200			
-	UANS NCT_X	NCT X = 6,300A/Inner diameter 200			
Door lock (On/Off)	-	UANS DL_CO	Pannel door lock for ON/OFF (in case of ON) → In course of development	Separately order	-
Door lock (Position)	-	UANS DL_PO	Pannel door lock for position (in case of test or connected) → In course of development	Separately order	-
Insulation barrier	-	UANS PBAR	Insulation barrier	Separately order	-
Draw-in/out handle	-	UANS LHANDLE	Long head type draw in-out handle	Separately order	-
	-	UANS UHANDLE	Universal join head draw in-out handle		
	-	UANS THANDLE	T grip long type draw in-out handle		
	-	UANS HANDLE	Standard draw in-out handle		
Dummy ACB/A3	-	UANS DUA3	Dummy ACB 06A3 - 20A3	Separately order	-
Dummy ACB/A4	-	UANS DUA4	Dummy ACB 06A4 - 20A4	Separately order	-
Dummy ACB/B3	-	UANS DUB3	Dummy ACB 20B3 - 40B3	Separately order	-
Dummy ACB/B4	-	UANS DUB4	Dummy ACB 20B4 - 40B4	Separately order	-
Dummy ACB/C3	-	UANS DUC3	Dummy ACB 32C3 - 50C3	Separately order	-
Dummy ACB/C4	-	UANS DUC4	Dummy ACB 32C4 - 50C4	Separately order	-
Draw-out device	-	UANS DR	Dr device unit/for service	Separately order	-
Arc chamber	-	UANS DIA	Arc chamber (A & C frame)	Separately order	-
	-	UANS DIB	Arc chamber (B frame)		
Front cover	-	UANS COV A3	Front cover set A3	Separately order	-
	-	UANS COV A4	Front cover set A4		
	-	UANS COV B3	Front cover set B3		
	-	UANS COV B4	Front cover set B4		
	-	UANS COV C3	Front cover set C3		
	-	UANS COV C4	Front cover set C4		
Terminal mold	-	UANS TMOLD A3	Cradle terminal mold A3	Separately order	-
	-	UANS TMOLD A4	Cradle terminal mold A4		
	-	UANS TMOLD B3	Cradle terminal mold B3		
	-	UANS TMOLD B4	Cradle terminal mold B4		
	-	UANS TMOLD C3	Cradle terminal mold C3		
	-	UANS TMOLD C4	Cradle terminal mold C4		

Accessories

Overview

Item	Ordering codes		Specifications	Type of shipment	Page
	Attached	Order separately			
Main body ↔ cradle connection terminal (Draw-out type)	-	UANS CLA16	Connection terminal A16	Separately order	-
	-	UANS CLA20	Connection terminal A20/C50		
	-	UANS CLAB20	Connection terminal B20/25		
	-	UANS CLAB32	Connection terminal B32		
	-	UANS CLAB40	Connection terminal B40		
Isolating contact/5	-	UANS ISOL	Isolating contact for UAN	Separately order	-
Isolating contact/4	-	UANS ISOL4	4clip isolating contact for UAS	Separately order	-
Rear cover lower	-	UANS RCA3L	Cradle rear cover lower A frame 3P	Separately order	-
	-	UANS RCA4L	Cradle rear cover lower A frame 4P		
	-	UANS RCB3L	Cradle rear cover lower B frame 3P		
	-	UANS RCB4L	Cradle rear cover lower B frame 4P		
	-	UANS RCC3L	Cradle rear cover lower C frame 3P		
	-	UANS RCC4L	Cradle rear cover lower C frame 4P		
Rear cover upper	-	UANS RCA3U	Cradle rear cover upper A frame 3P	Separately order	-
	-	UANS RCA4U	Cradle rear cover upper A frame 4P		
	-	UANS RCB3U	Cradle rear cover upper B frame 3P		
	-	UANS RCB4U	Cradle rear cover upper B frame 4P		
	-	UANS RCC3U	Cradle rear cover upper C frame 3P		
	-	UANS RCC4U	Cradle rear cover upper C frame 4P		

- ※ 1) Terminal busbar (drawout type) A frame 630 - 1,600A / B frame 2,000 - 3,200A - only drawout type can be ordered.
- 2) Terminal busbar (fixed type) A frame 630 - 1,600A / B frame 2,000 - 3,200A - only fixed type can be ordered.
- 3) Auxiliary switch: AUX SW UAS type standard DO contact is 3a + 3b, UAN type standard DO contact is 5a + 5b.
- 4) Motor: If you want to order motor as set for motor installation, inquire us separately.
- 5) UVT delay type controller: UVT delay type controller can be attached outside of main body or cradle.
- 6) Protection relay (OCR) is 50Hz Type: 5□/60Hz Type: 6□.
- 7) Position switch cannot be used more than one, and can be attached on the right side of cradle.
- 8) Mechanical interlock unit is wire type. MI unit can be attached on the outside of main body or cradle, and interlock device can be attached inside of main body.

Motor

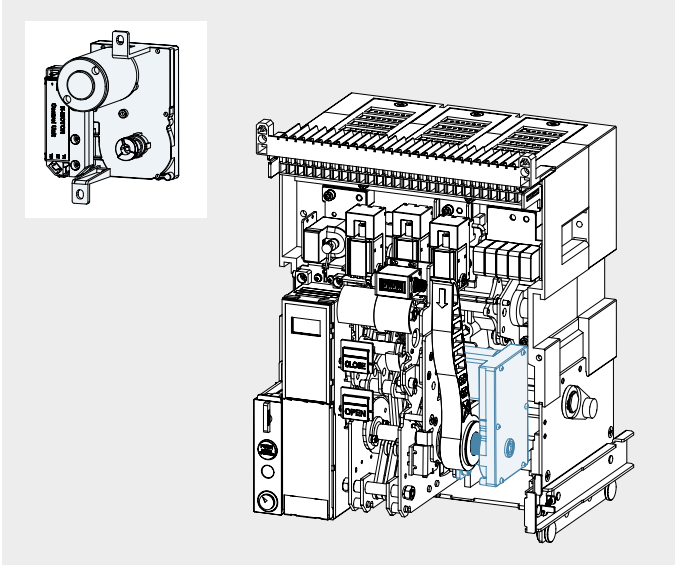

- Manual charging method and geared motor charging by external power source.
- Operating voltage range: 85 - 110 %
- When ordering, add M1-M9 in the order form.
- It can be ordered separately.

Ordering code

Item	Ordering code		Specification	Application		Mounting position
	Complete parts of ACB/Cradle	Spare part		UAN	UAS	
Motor	M1	UANS M1	AC/DC110V	○	○	Inside of ACB body
	M2	UANS M2	AC/DC220V	○	○	
	M3	UANS M3	AC380V	○	○	
	M4	UANS M4	AC440V	○	○	
	M7	UANS M7	DC24V	○	○	
	M8	UANS M8	DC48V	○	○	
	M9	UANS M9	DC125V	○	○	

Ratings

	Rated voltage	
	DC110V	DC220V
Rated current (A)	1.2	0.5
Starting pick-up (A)	5 - 6 times of rated current	
Revolutions per minute (RPM)	16±3	
Charging time (sec)	within 5 sec ¹⁾	
Torque (kgf)	300kgf x cm	
Rated watt (W)	100	100
Insulation voltage (V/min)	2,000	
Insulation resistance (MΩ)	100	
Ambient temperature (°C)	- 15 - 60	

※ 1) Charging time is within 10 sec of rated, in case of DC24/48V.

Wire ratings

Rated voltage			
DC24/48V		DC110/220V	
AWG	Insulation level (V)	AWG	Insulation level (V)
18	600	18	600

Connection diagram

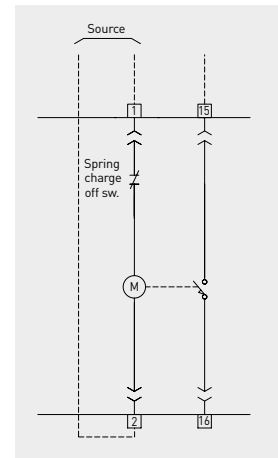

Spring charging switch

- These contacts (No. 15,16) are for delivering spring charge status to outside.
- Optional device mounted on the body.
- Ordering code: B6, UANS B6 (Spare part)

Accessories

| Closing coil |

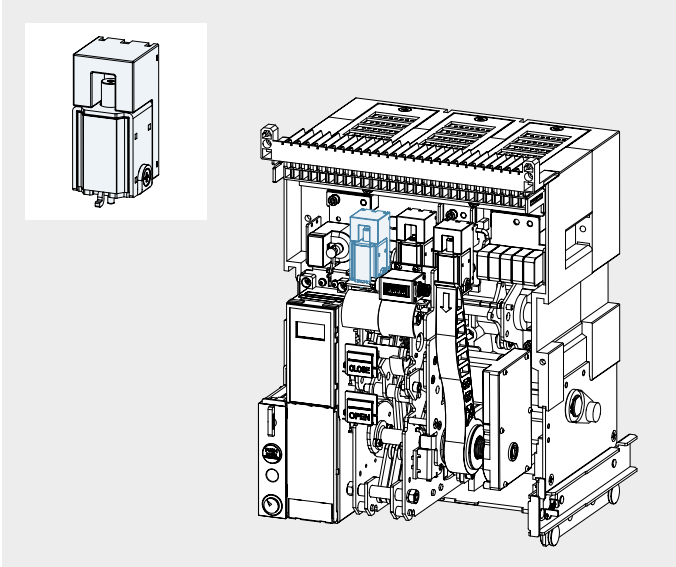

- A control device which closes a circuit breaker remotely, when applying 85 - 110 % of rated control voltage over 150 ms to coil terminals (3,4).
- When ordering, add C1 - C9 in the order form.
- It can be ordered separately.
- Use a separate switch when supplying voltage to a closing coil.

■ Ordering code

Item	Ordering code		Specification	Application		Mounting position
	Complete parts of ACB/Cradle	Spare part		UAN	UAS	
Closing coil	C1	UANS C1	AC/DC110V	<input type="radio"/>	<input type="radio"/>	Inside of ACB body
	C2	UANS C2	AC/DC220V	<input type="radio"/>	<input type="radio"/>	
	C3	UANS C3	AC380V	<input type="radio"/>	<input type="radio"/>	
	C4	UANS C4	AC440V	<input type="radio"/>	<input type="radio"/>	
	C7	UANS C7	DC24V	<input type="radio"/>	<input type="radio"/>	
	C8	UANS C8	DC48V	<input type="radio"/>	<input type="radio"/>	
	C9	UANS C9	DC125V	<input type="radio"/>	<input type="radio"/>	

■ Ratings

Power supply (Vn)		Operating limits	Power consumption (VA)		Closing time (ms)
DC (V)	AC (V)		Inrush	Steady-state	
24	-	0.85 - 1.1Vn	300	10	80
100 - 130	100 - 130	0.85 - 1.1Vn			
200 - 250	200 - 250	0.85 - 1.1Vn			

■ Connection diagram

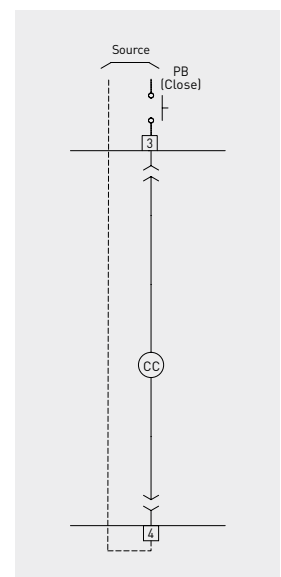

■ Wire ratings

Rated voltage (Vn)			
DC24		AC/DC110/220	
AWG [mm²]	Insulation level (V)	AWG [mm²]	Insulation level (V)
20	600	20	600

| Trip coil |

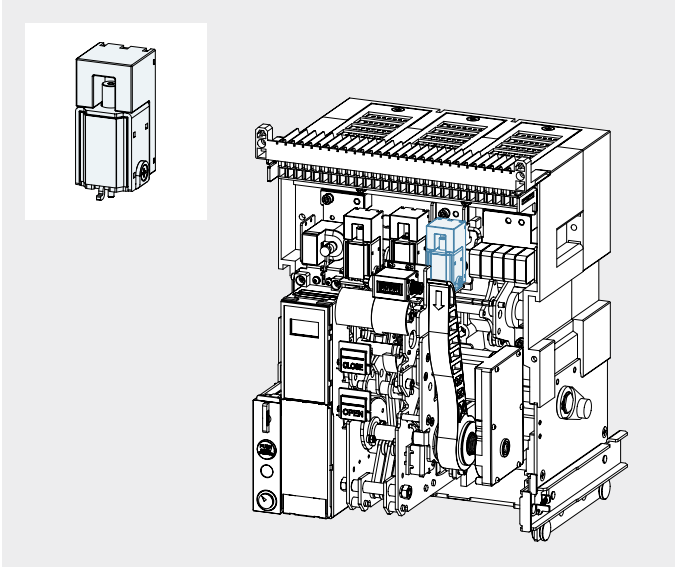

- A control device which trips a circuit breaker remotely, when applying 70 - 110 % of rated control voltage over 150 ms to coil terminals (7,8).
- When ordering, add S1 - S9 to the order form.
- It can be ordered separately.
- Use a separate switch when supplying voltage to a trip coil.

■ Ordering code

Item	Ordering code		Specification	Application		Mounting position
	Complete parts of ACB/Cradle	Spare part		UAN	UAS	
Trip coil	S1	UANS S1	AC/DC110V	<input type="radio"/>	<input type="radio"/>	Inside of ACB body
	S2	UANS S2	AC/DC220V	<input type="radio"/>	<input type="radio"/>	
	S3	UANS S3	AC380V	<input type="radio"/>	<input type="radio"/>	
	S4	UANS S4	AC440V	<input type="radio"/>	<input type="radio"/>	
	S7	UANS S7	DC24V	<input type="radio"/>	<input type="radio"/>	
	S8	UANS S8	DC48V	<input type="radio"/>	<input type="radio"/>	
	S9	UANS S9	DC125V	<input type="radio"/>	<input type="radio"/>	

■ Ratings

Power supply (Vn)		Operating limits	Power consumption (VA)		Trip time (ms)
DC (V)	AC (V)		Inrush	Steady-state	
24	-	0.7 - 1.1Vn	300	10	40
100 - 130	100 - 130	0.7 - 1.1Vn			
200 - 250	200 - 250	0.7 - 1.1Vn			

■ Wire ratings

Rated voltage (Vn)			
DC24		AC/DC110/220	
AWG [mm ²]	Insulation level (V)	AWG [mm ²]	Insulation level (V)
20	600	20	600

■ Connection diagram

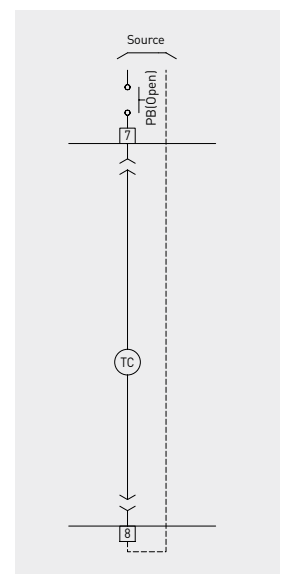

Accessories

| Secondary trip coil |

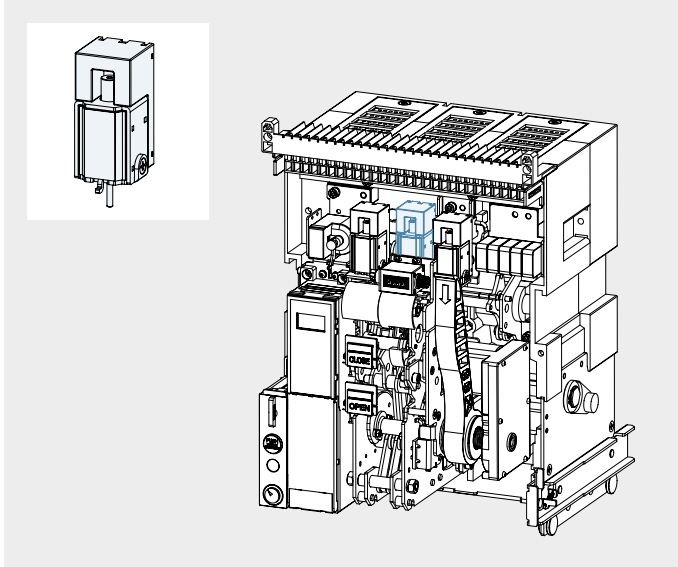

- A control device which trips a circuit breaker doubly from the outside.
- Not available with UVT (Under-voltage trip) coil when installing double trip coil.
- Rated control voltage range 70 - 110 %, applying voltage over 150 ms to coil terminals (9,10).
- When using secondary coil, UVT coil cannot be used at the same time.
- When ordering, add S1 - S9 to the order form and to the option order part.
- It can be ordered separately.
- Use a separate switch when supplying voltage to a trip coil.

■ Ordering code

Item	Ordering code		Specification	Application		Mounting position
	Complete parts of ACB/Cradle	Spare part		UAN	UAS	
Secondary trip coil	S1	UANS SS1	AC/DC110V	<input type="radio"/>	<input type="radio"/>	Inside of ACB body
	S2	UANS SS2	AC/DC220V	<input type="radio"/>	<input type="radio"/>	
	S3	UANS SS3	AC380V	<input type="radio"/>	<input type="radio"/>	
	S4	UANS SS4	AC440V	<input type="radio"/>	<input type="radio"/>	
	S7	UANS SS7	DC24V	<input type="radio"/>	<input type="radio"/>	
	S8	UANS SS8	DC48V	<input type="radio"/>	<input type="radio"/>	
	S9	UANS SS9	DC125V	<input type="radio"/>	<input type="radio"/>	

■ Ratings

Power supply (Vn)		Operating limits	Power consumption (VA)		Trip time (ms)
DC (V)	AC (V)		Inrush	Steady-state	
24	-	0.7 - 1.1Vn	300	10	40
100 - 130	100 - 130				
200 - 250	200 - 250				

■ Wire ratings

Rated voltage (Vn)			
DC24		AC/DC110/220	
AWG [mm ²]	Insulation level (V)	AWG [mm ²]	Insulation level (V)
20	600	20	600

■ Connection diagram

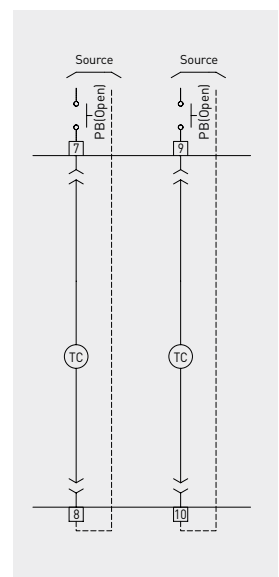

Tripping coil supervision

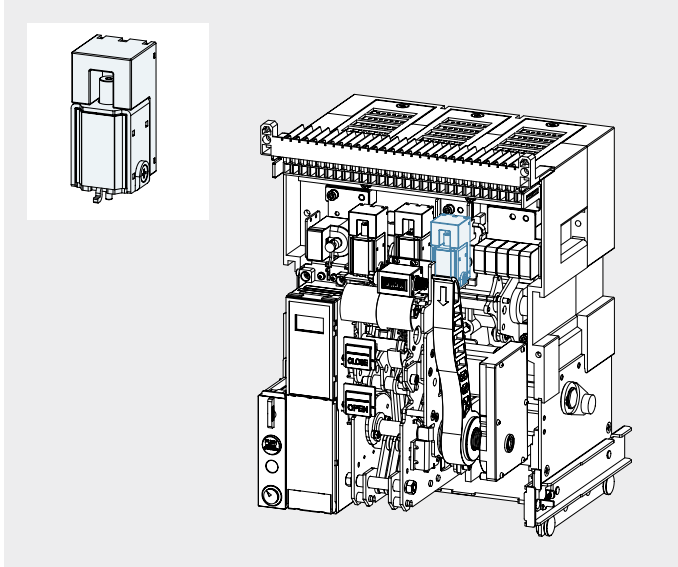

- To trip the circuit breaker, 70 - 110 % of rated control voltage should be applied to both terminals (7,8) over 150 ms.
- Add your selection (S1 - S9) to main body's ordering code and mark T1 - T9 in option list.
- When using trip coil supervision, aux. contact is 4a3b (Not available aux. switch 43/44, 53/54).
- Output contact is No. 59.
- Coil supervision checks not only circuit's mechanical contact but also the condition of coil
- When ordering, add T1 - T9 to the order form.
- When using trip supervision coil, 6a6b aux. Contact is not available (Addition of 1a1b is not applicable).

Ordering code

Item	Ordering code		Specification	Application		Mounting position
	Complete parts of ACB/Cradle	Spare part		UAN	UAS	
Trip supervision coil	T1	UANS T1	AC/DC110V	○		Inside of ACB body
	T2	UANS T2	AC/DC220V	○		
	T3	UANS T3	AC380V	○		
	T4	UANS T4	AC440V	○		
	T7	UANS T7	DC24V	○		
	T8	UANS T8	DC48V	○		
	T9	UANS T9	DC125V	○		

Ratings

Power supply (Vn)		Operating limits	Power consumption (VA)		Trip time (ms)
DC (V)	AC (V)		Inrush	Steady-state	
24	-	0.7 - 1.1Vn	300	10	40
100 - 130	100 - 130	0.7 - 1.1Vn			
200 - 250	200 - 250	0.7 - 1.1Vn			

Wire ratings

Rated voltage (Vn)			
DC24		AC/DC110/220	
AWG [mm²]	Insulation level (V)	AWG [mm²]	Insulation level (V)
20	600	20	600

Connection diagram

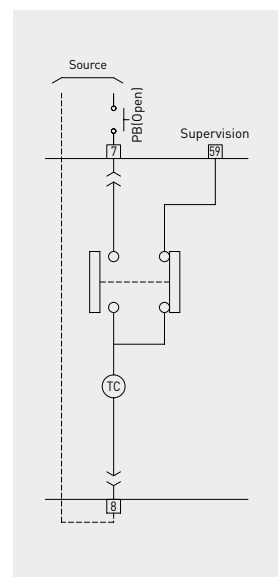

Accessories

| UVT coil |

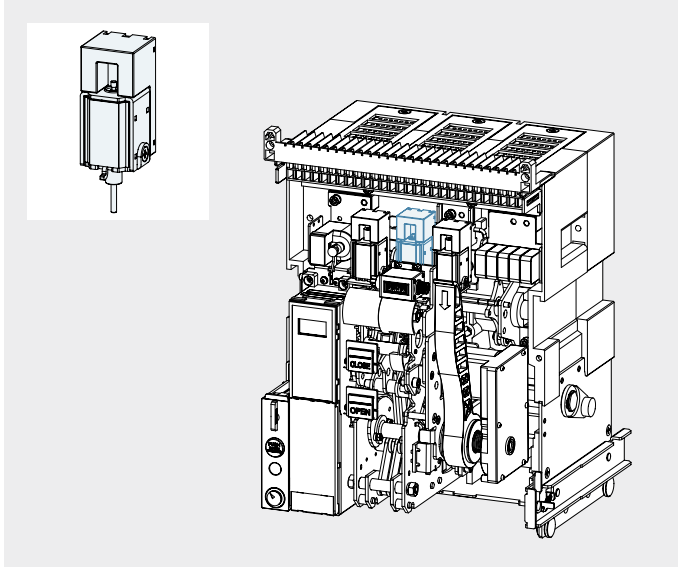

- If the voltage of the main or the control power is under 70 % of the standard, UVT breaks the circuit automatically.
- Connect instantaneous type with both terminals (9,10) and connect with time delay type in order to present time delay controller.
- - The circuit breaker is opened with trip unit power supply voltages below 70 %.
- - The circuit breaker is closed with unit power supply voltage above 85 %.
- Instantaneous type can not be used with double trip coil.
- When using instantaneous type, add U1 - U9 in the order form.
- It can be ordered separately.

■ Ordering code

Item	Ordering code		Specification	Application		Mounting position
	Complete parts of ACB/Cradle	Spare part		UAN	UAS	
UVT Coil (Instantaneous type)	U1	UANS U1	AC/DC110V	<input type="radio"/>	<input type="radio"/>	Inside of ACB body
	U2	UANS U2	AC/DC220V	<input type="radio"/>	<input type="radio"/>	
	U3	UANS U3	AC380V	<input type="radio"/>	<input type="radio"/>	
	U4	UANS U4	AC440V	<input type="radio"/>	<input type="radio"/>	
	U7	UANS U7	DC24V	<input type="radio"/>	<input type="radio"/>	
	U8	UANS U8	DC48V	<input type="radio"/>	<input type="radio"/>	
	U9	UANS U9	DC125V	<input type="radio"/>	<input type="radio"/>	

■ Ratings

Power supply (Vn)		Pickup	Drop	Power consumption (VA)		Trip time (ms)
DC (V)	AC (V)			Inrush	Steady-state	
24	-	Above 0.85Vn	Below 0.35Vn	300	10	50
110 (100 - 130)	110 (100 - 130)					
220 (200 - 250)	220 (200 - 250)					
-	380					
-	440					

■ Connection diagram

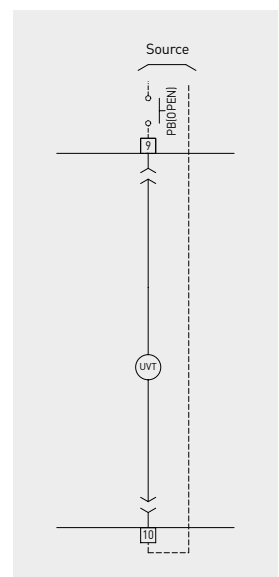

■ Wire ratings

Rated voltage (Vn)					
DC24		AC/DC110/220		AC380/440	
AWG [mm ²]	Insulation level (V)	AWG [mm ²]	Insulation level (V)	AWG [mm ²]	Insulation level (V)
20	600	20	600	20	600

| UVT time delay controller |

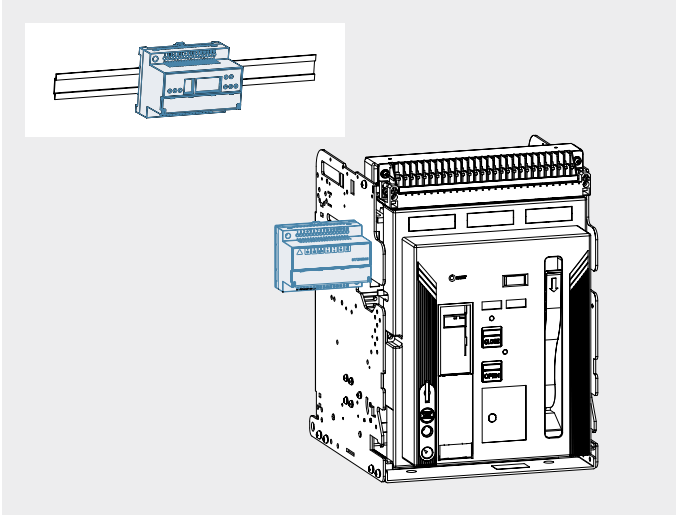

- Use of UVT time delay controller is recommended to prevent tripping when the power supply network for the trip unit is subject to brief voltage drops or power supply failures.
- This device is possible to delay as (0.5, 1.0, 1.5, 3 sec).
- It can be mounted at the left side of cradle or the DIN rail.
- Controller is mounted at cradle (Draw-out type) or outside of main body (Fixed type).
- When ordering, add V1 - V9 in the order form. Time delay controller will be included in the packing.
- When ordering UVT time delay controller only, please order the separate product, UANS UT1 - UT9.

■ Ordering code

Item	Ordering code		Specification	Application		Mounting position
	Complete parts of ACB/Cradle	Spare part		UAN	UAS	
UVT time delay controller	-	UANS UT1	AC/DC110V	○	○	Outside of ACB body & cradle
	-	UANS UT2	AC/DC220V	○	○	
	-	UANS UT3	AC380V	○	○	
	-	UANS UT4	AC440V	○	○	
	-	UANS UT9	DC125V	○	○	
UVT time delay controller & UVT coil (Instantaneous type)	V1	UANS V1	AC/DC110V	○	○	• Controller: outside of ACB body & cradle
	V2	UANS V2	AC/DC220V	○	○	
	V3	UANS V3	AC380V	○	○	
	V4	UANS V4	AC440V	○	○	• UVT coil: inside of ACB body
	V7	UANS V7	DC24V	○	○	
	V8	UANS V8	DC48V	○	○	
V9	UANS V9	DC125V	○	○		

■ Connection & Operating time

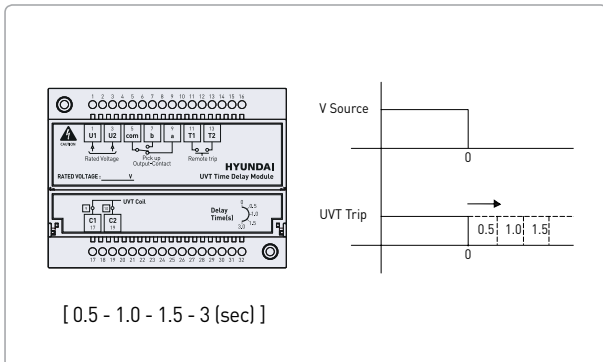

※ The condition of 5, 7, 9 contacts is the state when UVT's operation.

■ Connection diagram

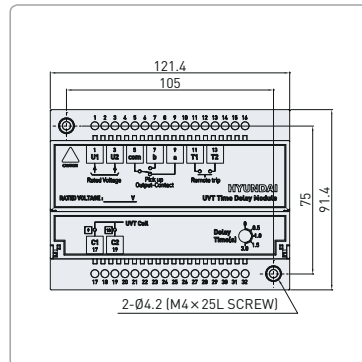

■ Connection diagram

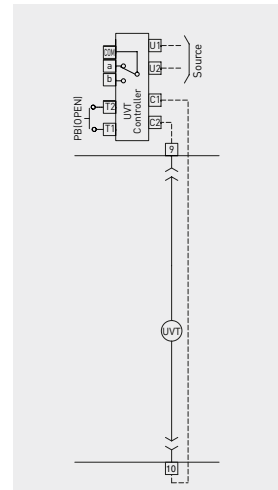

Accessories

| Auxiliary switch |

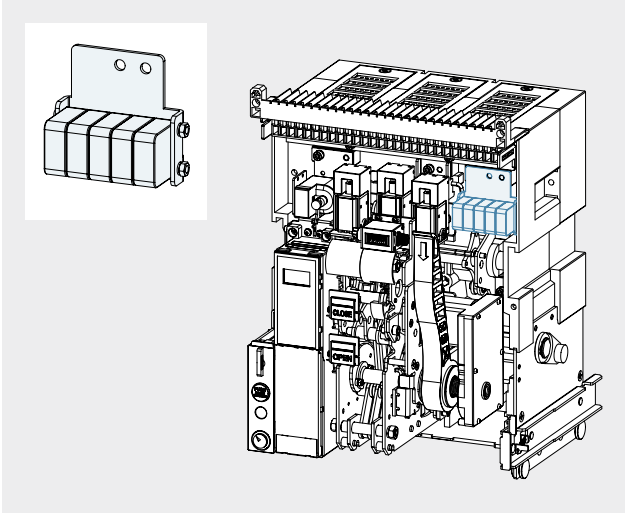

- A contact to monitor On/Off position of ACB remotely.
- 3a3b is provided as standard for UAS type and 5a5b is standard for UAN type.
- Applicable AUX switch is up to 6a6b. Add AA on your order.
- When working with monitoring contact for trip coil the AUX switch will be 3a3b. When working with OCR's MCR function it will be 4a3b.
- When ordering short "b" additionally it will be attached to 'b' contacts 51, 52 when the product is out. The additional short b which enclosed in the product is applicable as the number of the b contact.
- 5a5b can be ordered separately. Add UANS AS on extra order.

■ Ratings

Load	Resistance	Lamp	Inductor	Motor
AC125V	5A	0.7A	4A	1.3A
AC250V	5A	0.5A	4A	0.8A

■ Wire ratings

Wire ratings	
AWG	Insulation level (V)
20	300

■ Connection diagram

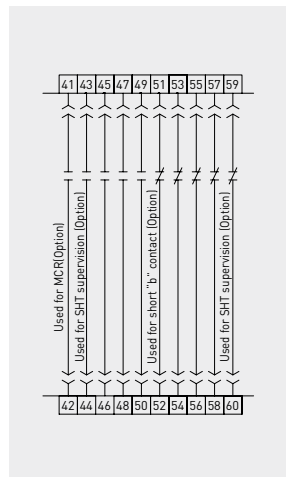

■ Ordering code

Item	Ordering code		Specification	Application		Mounting position
	Complete parts of ACB/Cradle	Spare part		UAN	UAS	
Auxiliary switch	-	UANS A3A	Auto connection type, 3a + 3b		○	Inside of ACB body
	-	UANS A3J	Manual connection type, 3a + 3b		○	
	A5	UANS A5A	Auto connection type, 5a + 5b	○	○	
	A5	UANS A5J	Manual connection type, 5a + 5b	○	○	
	AA	UANS AA	Additional 1a1b (Max. 6a6b)	○	○	

| Test jumper |

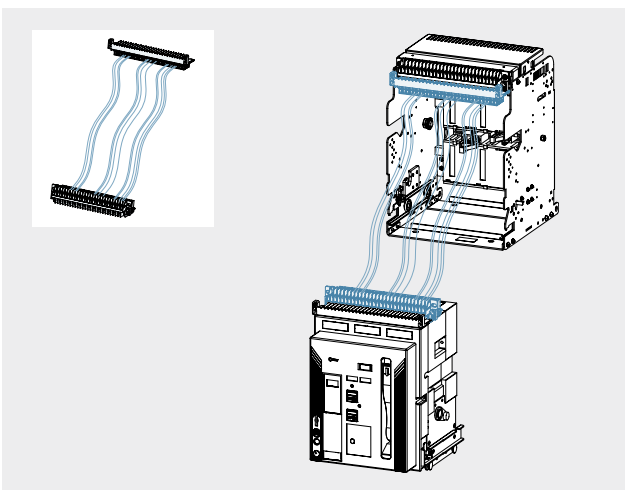

- A connecting device to make the body of auto connection type operate separately.
- Ordering code: UANS AJ (Spare part)

| Position switch |

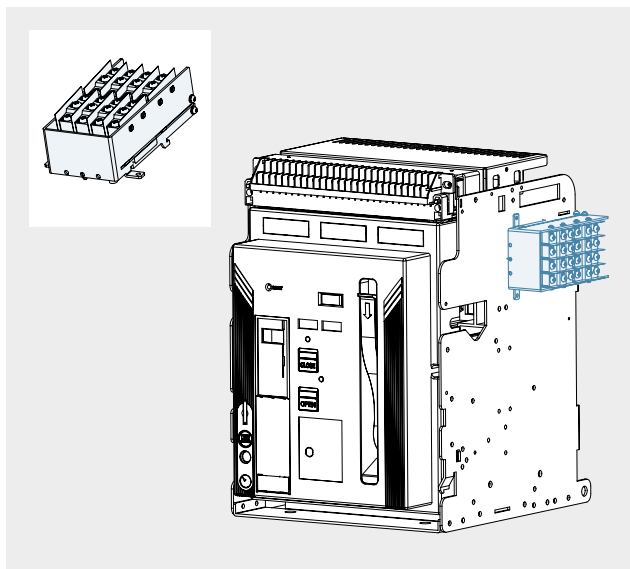

- This switch is for indicating the position of ACB in the cradle. It is mounted on the side of cradle.
- Indicating position Connected/Test/Isol/Insert.
- Only one switch is applicable.

■ Ratings

Load	Resistance	Lamp	Inductor	Motor
AC125V	10A	1.5A	6A	2A
DC30V	6A	3A	6A	3A
DC125V	0.6A	0.1A	0.6A	0.1A
DC250V	0.3A	0.05A	0.3A	0.05A

■ Composition

Item	Ordering code		Specification	Application		Inserted	Isolated	Test	Connected	Mounting position
	Complete parts of ACB/Cradle	Spare part		UAN	UAS					
Position switch	AQ	UANS AQ	Test 1C, Connected 1C	○	○	—	—	○(1C)	○(1C)	Right side of cradle
	AR	UANS AR	Connected 2C	○	○	—	—	—	○(2C)	
	AS	UANS AS	Test 2C	○	○	—	—	○(2C)	—	
	AT	UANS AT	Isolated 1C, Inserted 1C	○	○	○(1C)	○(1C)	—	—	
	AU	UANS AU	Inserted 2C	○	○	○(2C)	—	—	—	
	AV	UANS AV	Isolated 2C	○	○	—	○(2C)	—	—	
	P4	UANS P4	Test 2C, Connected 2C	○	○	—	—	○(2C)	○(2C)	
	PS	UANS PS	Isolated 1C, Test 1C, Connected 2C	○	○	—	○(1C)	○(1C)	○(2C)	
	PQ	UANS PQ	Inserted 1C, Isolated 1C, Test 1C, Connected 1C	○	○	○(1C)	○(1C)	○(1C)	○(1C)	
	PR	UANS PR	Inserted 1C, Isolated 1C, Test 3C, Connected 3C	○	○	○(1C)	○(1C)	○(3C)	○(3C)	
	P8	UANS P8	Inserted 2C, Isolated 2C, Test 2C, Connected 2C	○	○	○(2C)	○(2C)	○(2C)	○(2C)	
PT	UANS PT	Test 4C	○	○	—	—	○(4C)	—		

■ Position switch operating sequence

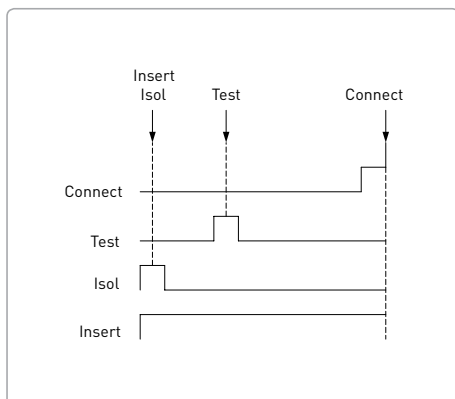

■ Connection diagram

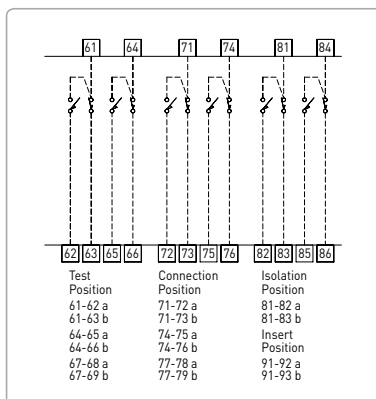

■ Exterior

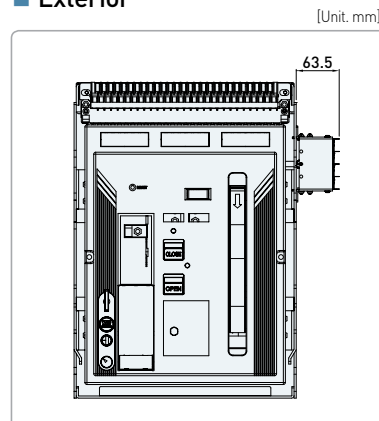

Accessories

| Condenser trip device |



- In case of using AC/DC power for trip control, it gets a circuit breaker tripped once electrically when power supply is broken down.
- It can be ordered separately.

■ Ordering code

Item	Ordering code		Specification	Application		Mounting position
	Complete parts of ACB/Cradle	Spare part		UAN	UAS	
Condenser trip device (CTD)	-	UANS CTD1	AC/DC110V	○	○	
	-	UANS CTD2	AC/DC220V	○	○	

■ CTD operating sequence

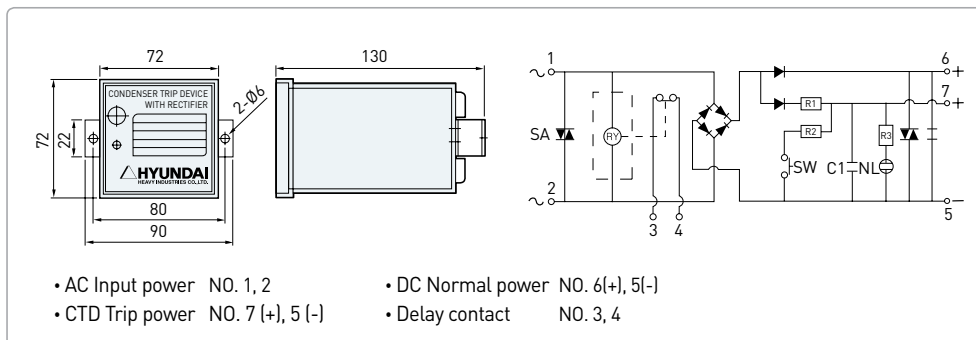

■ Connection diagram

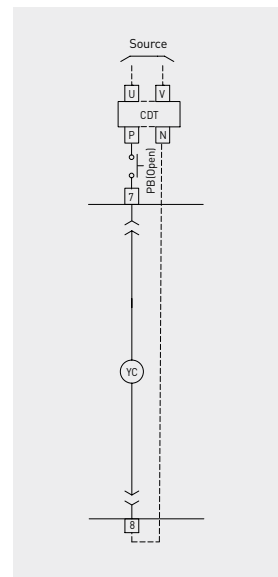

■ Ratings

Rated input voltage	AC110V	AC220V
Normal charging voltage	DC145V	DC290V
Normal current capacity	DC2A	
Rated frequency	50/60Hz	
Delay circuit time	within 1.5 sec	
Applicable standards	IEC 60694 / KSC 4611	

| Lifting lug |

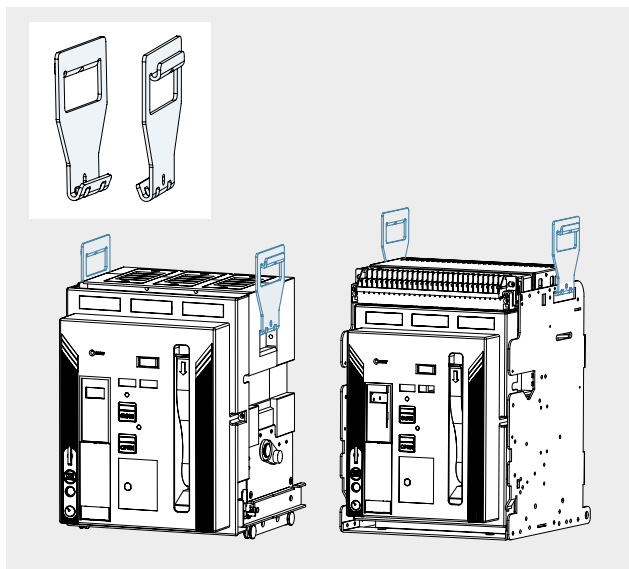

- A device to make an ACB easy to shift.
- Hang it to both handles of the arc shield, cradle, and ACB.
- When handling products, please be sure to use crane. In case of products under 3,200A and handling cradle only, please comply with safety regulation.
- Offered 2ea of 1set as a standard in "C", "D" frame. (more than 5,000AF)
- When ordering separately, please order UANS AL.

■ Ordering code

Item	Ordering code		Specification	Application		Mounting position
	Complete parts of ACB/Cradle	Spare part		UAN	UAS	
Lifting lug	-	UANS AL	2ea/set (Supplied as standard only for C frame)	○	○	Outside of ACB body & cradle

| Dummy ACB |

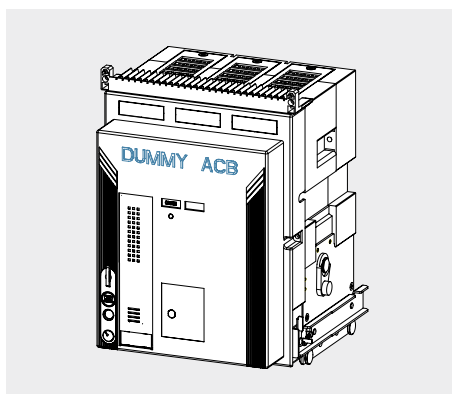

- The dummy ACB which is a frame to apply electric current can conduct ACB's function temporarily when the maintenance work takes long due to malfunction.
- When connecting the dummy ACB please check the primary power is out since the CB is close.
- The early stage of each frame is maximum rated current.
- It can be ordered separately.

■ Ordering code

Item	Ordering code		Specification	Application		Mounting position
	Complete parts of ACB/Cradle	Spare part		UAN	UAS	
Dummy ACB	-	UANS DUA3	A frame, 630 - 2,000A, 3P	○	○	Outside of ACB body & cradle
	-	UANS DUA4	A frame, 630 - 2,000A, 4P	○	○	
	-	UANS DUB3	B frame, 2,000 - 4,000A, 3P	○	○	
	-	UANS DUB4	B frame, 2,000 - 4,000A, 4P	○	○	
	-	UANS DUC3	C frame, 4,000 - 5,000A, 3P	○	○	
	-	UANS DUC4	C frame, 4,000 - 5,000A, 4P	○	○	

Accessories

| Mechanical interlock kit |

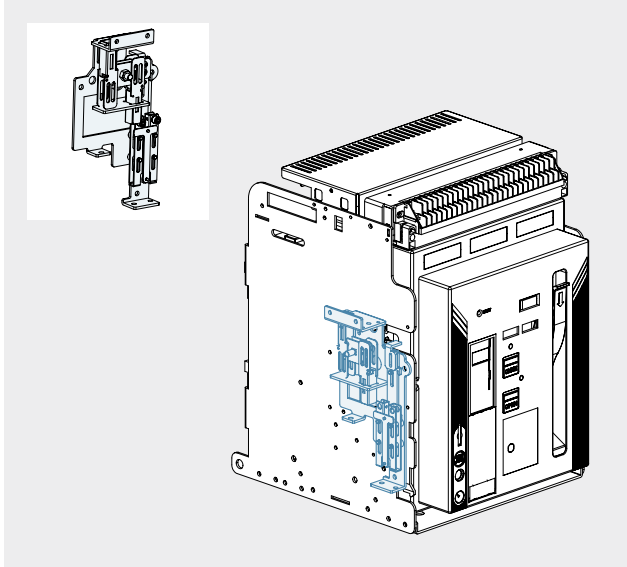

- It is used to interlock closing and trip between two or three breakers mechanically so as to prevent unintended operation at the same time.
- The MI is a safety gear installed in ACB for distribution line and it creates a mechanical interlock between two or three circuit-breakers through each CB's open/close work.
- To operate the MI every component linked to the MI unit and the MI must be combined before use.
- MI unit is separate product. After installing ACB it is additionally attached.
- When ordering B0 all components linked to the MI unit are provided.
- Order other separate kits when having purchased only ACB without B0.
- MI wire should be connected under 2m between ACBs.
- In order to installation, need to square hole 100×200 (mm).

■ Ordering code

Item	Ordering code		Specification	Application		Mounting position
	Complete parts of ACB/Cradle	Spare part		UAN	UAS	
Mechanical interlock kit	-	UANS DWB1	for draw-out type, 2 way interlock	○		Outside of ACB body & cradle
	-	UANS DWB2	for draw-out type, 3 way interlock	○		
	-	UANS FAWB1	for A/C frame, fixed type, 2 way interlock	○		
	-	UANS FAWB2	for A/C frame, fixed type, 3 way interlock	○		
	-	UANS FBWB1	for B frame, fixed type, 2 way interlock	○		
	-	UANS FBWB2	for B frame, fixed type, 3 way interlock	○		
Mechanical interlock kit & ACB internal interlock part	-	UANS DWB1A	for A frame, draw-out type, 2 way interlock	○		• Interlock kit: outside of ACB body or cradle
	-	UANS DWB2A	for A frame, draw-out type, 3 way interlock	○		
	-	UANS DWB1B	for B frame, draw-out type, 2 way interlock	○		
	-	UANS DWB2B	for B frame, draw-out type, 3 way interlock	○		
	-	UANS DWB1C	for C frame, draw-out type, 2 way interlock	○		
	-	UANS DWB2C	for C frame, draw-out type, 3 way interlock	○		
	-	UANS FWB1A	for A frame, fixed type, 2 way interlock	○		• Interlock part: inside of ACB body
	-	UANS FWB2A	for A frame, fixed type, 3 way interlock	○		
	-	UANS FWB1B	for B frame, fixed type, 2 way interlock	○		
	-	UANS FWB2B	for B frame, fixed type, wire type, 3 way interlock	○		
	-	UANS FWB1C	for C frame, fixed type, wire type, 2 way interlock	○		
	-	UANS FWB2C	for C frame, fixed type, wire type, 3 way interlock	○		

| Terminal busbar |

Standard connection

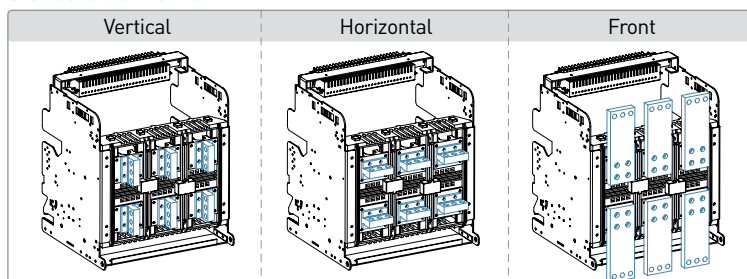

Mixed connection (Top/Bottom)

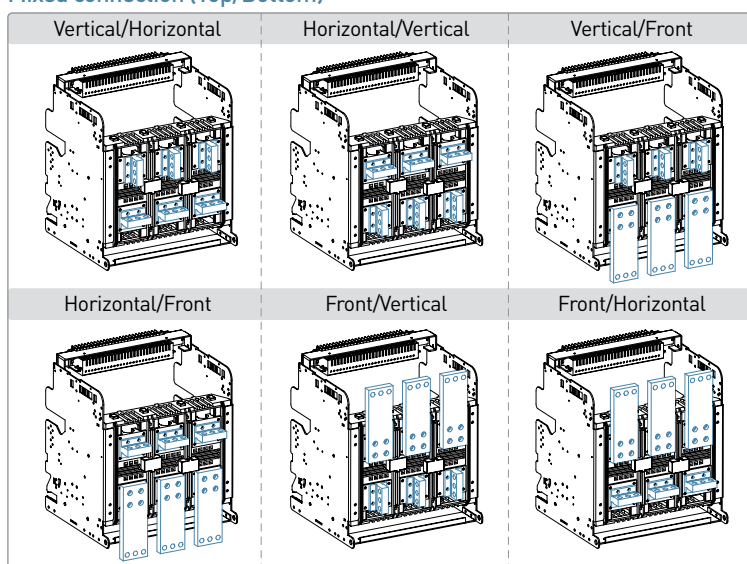

- U-Series ACB have the following front types: Vertical, horizontal, top vertical-bottom horizontal and top horizontal-bottom vertical type. There are also P-types which have no terminal cradle and fixed body type. For these models (P and fixed body type) separate terminal is additionally supplied.
- Separate terminal is applicable for only A-frame 630 - 1,600[A] and B-frame 2,000 - 3,200[A].
- Separate terminal is applicable for only A-frame 630 - 1,600[A] and B-frame 2,000 - 3,200[A].
- Horizontal terminal busbar is delivered separately with ACB and its cradle, so it needs to be installed at site.
- For 2,000/2,500A B-frame, 3,200A terminal busbar is provided.

■ Ordering code

Item	Ordering code		Specification	Application		Mounting position
	Complete parts of ACB/Cradle	Spare part		UAN	UAS	
Terminal busbar	-	UANS HVA3	Horizontal/Vertical type 6ea for A frame, 630 - 1,600A, 3P	○	○	Outside of ACB body & cradle
	-	UANS HVA4	Horizontal/Vertical type 8ea for A frame, 630 - 1,600A, 4P	○	○	
	-	UANS HVB3	Horizontal/Vertical type 6ea for B frame, 630 - 3,200A, 3P	○	○	
	-	UANS HVB4	Horizontal/Vertical type 8ea for B frame, 630 - 3,200A, 4P	○	○	
Terminal busbar for fixed type	-	UANS FRA3F	Front type 6ea for A frame, 630 - 1,600A, 3P	○	○	Outside of ACB body & cradle
	-	UANS FRA4F	Front type 8ea for A frame, 630 - 1,600A, 4P	○	○	
	-	UANS FRB3F	Front type 6ea for B frame, 2,000 - 3,200A, 3P	○	○	
	-	UANS FRB4F	Front type 8ea for B frame, 2,000 - 3,200A, 4P	○	○	
	-	UANS FHVA3F	Front type 3ea & Horizontal/Vertical type 3ea for A frame, 630 - 1,600A, 3P	○	○	
	-	UANS FHVA4F	Front type 4ea & Horizontal/Vertical type 4ea for A frame, 630 - 1,600A, 4P	○	○	
	-	UANS FHVB3F	Front type 3ea & Horizontal/Vertical type 3ea for B frame, 630 - 3,200A, 3P	○	○	
	-	UANS FHVB4F	Front type 4ea & Horizontal/Vertical type 4ea for B frame, 630 - 3,200A, 4P	○	○	
Terminal busbar for draw-out type	-	UANS FRA3	Front type 6ea for A frame, 630 - 1,600A, 3P	○	○	Outside of ACB body & cradle
	-	UANS FRA4	Front type 8ea for A frame, 630 - 1,600A, 4P	○	○	
	-	UANS FRB3	Front type 6ea for B frame, 2,000 - 3,200A, 3P	○	○	
	-	UANS FRB4	Front type 8ea for B frame, 2,000 - 3,200A, 4P	○	○	
	-	UANS FHVA3	Front type 3ea & Horizontal/Vertical type 3ea for A frame, 630 - 1,600A, 3P	○	○	
	-	UANS FHVA4	Front type 4ea & Horizontal/Vertical type 4ea for A frame, 630 - 1,600A, 4P	○	○	
	-	UANS FHVB3	Front type 3ea & Horizontal/Vertical type 3ea for B frame, 630 - 3,200A, 3P	○	○	
	-	UANS FHVB4	Front type 4ea & Horizontal/Vertical type 4ea for B frame, 630 - 3,200A, 4P	○	○	

Accessories

| Phase insulation barrier |

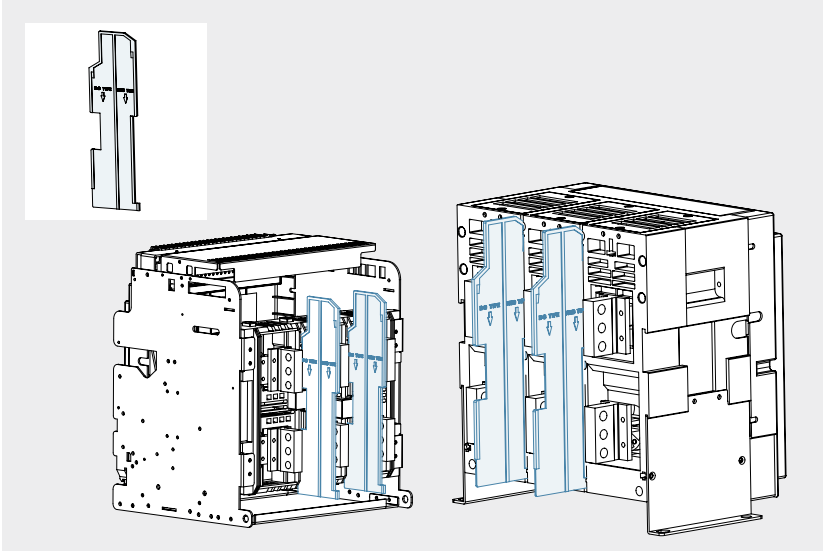

- Phase insulation barrier is installed between phases and prevents the arc which may arise and result in short-circuit between phase in advance.
- 3P type needs 2ea, and 4P type needs 3ea of phase insulation barrier, please specify the number of barriers when ordering.
- Please order UANS 3PBAR for 3P type, and UANS 4PBAR for 4P type.

■ Ordering code

Item	Ordering code		Specification	Application		Mounting position
	Complete parts of ACB/Cradle	Spare part		UAN	UAS	
Phase insulation barrier	-	UANS 3PBAR	for 3P	<input type="radio"/>	<input type="radio"/>	Terminal side of ACB body & cradle
	-	UANS 4PBAR	for 4P	<input type="radio"/>	<input type="radio"/>	

| ON/OFF button lock |

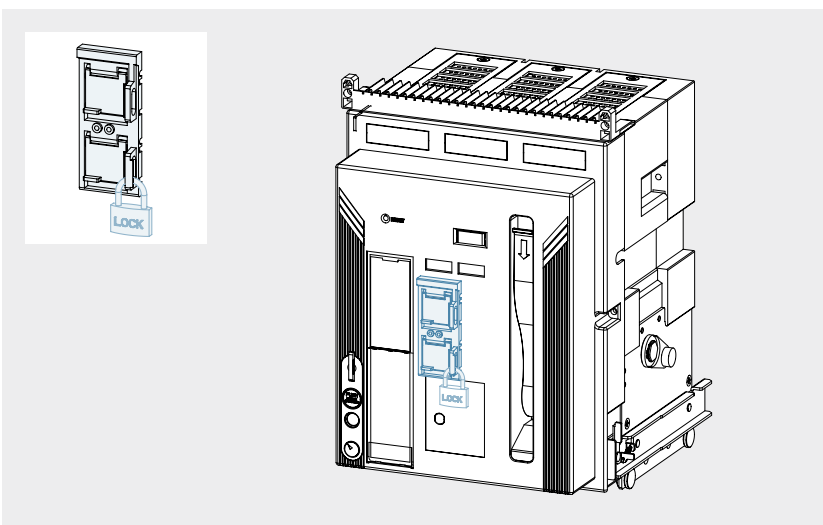

- Prevents manual operation of ACB's closing/tripping button due to user's wrong handling.
- It is not possible to handle on/off operation under the "Button lock" status.
- Padlock is not included, key lock size: $\phi 5 - \phi 8$
- It is delivered with ACB when "AM" is added in the order form.

■ Ordering code

Item	Ordering code		Specification	Application		Mounting position
	Complete parts of ACB/Cradle	Spare part		UAN	UAS	
ON/OFF button lock	AM	UANS AM	ON/OFF button cover with padlock hole	<input type="radio"/>	<input type="radio"/>	Outside of ACB body & cradle

| OCR portable checker |



- UAN portable checker tests for the operation of UAN OCR (Long time/Short time delay/Instantaneous/Ground fault).
- It is possible to set current level, phases, and frequency for OCR's test.
- All testing factors are adjustable through front monitor and you can check operating time.
- Battery equipped inside (Available without external power source).
- Ordering code: UANS OC (Spare part)

■ Connection diagram

Item	Specifications
External power	Input: AC/DC100 - 200V, 50/60Hz Output: DC24V, 2.5A
Battery	Alkaline 9V: 3ea
Trip time measurement	0 - 999,999 sec
Test output	0.3lct - 17lct
Output precision	±20 % (1lct - 17lct)
Size (H x W x D)	193mm x 111mm x 45mm

■ Key Pad



Number	Button	Function
1	UP	Move menu and increasing setpoint
2	DOWN	Move menu and decrease setpoint
3	FUNC	Move to the previous menu and return to the setup screen
4	ENTER	Save the settings and move the number of digits of setting current
5	START	Waveform occurrence
6	STOP	Waveform stop

■ Externals

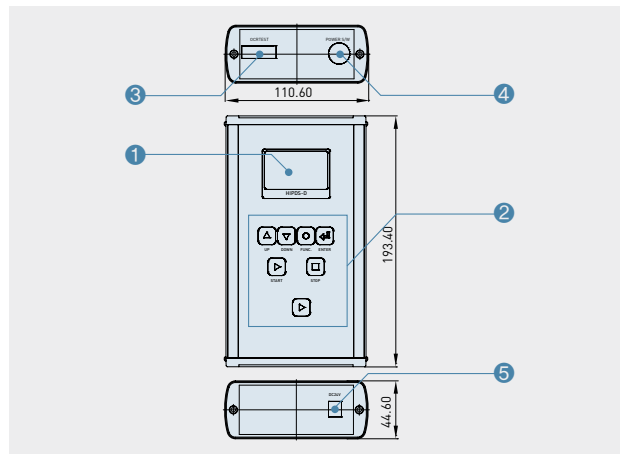

Number	Button	Function
1	LCD	Menu, setting current, trip time
2	Key pad	Move menu and setting
3	Signal output terminal	OCR connection terminals
4	Power switch	On/Off
5	Terminal	Control terminal of checker

Accessories

| Higher OCR checker |

- Higher checker is auxiliary testing device that verifies ACB operation with unloaded condition.
- It can test basic relays with connected to OCR.
- It can confirm the OCR information by communication.



- Control power: AC/DC85-270V (50Hz/60Hz)
- Size
 - Dimension : 411(L) x 321(W) x 165(H)
 - Weight : 8kg
- Main function
 - LTD, STD, INST, GFT tripping time and pick up test
 - PTA operating time test with connected to PTA contacting point
 - Fault information, setting information, fault phase and real time phase information can be checked from communication with OCR.

Item	Specification
Control power	AC/DC85 - 270V (50/60Hz)
Test output	Output Channel: 4 (R, S, T, N) Test output: 0.4 - 17 Ict Precision: $\pm 3\%$
Input	Communication: RS 485 Touch-Screen of HMI
Size	411 x 321 x 165mm 8kg

| Key lock device |

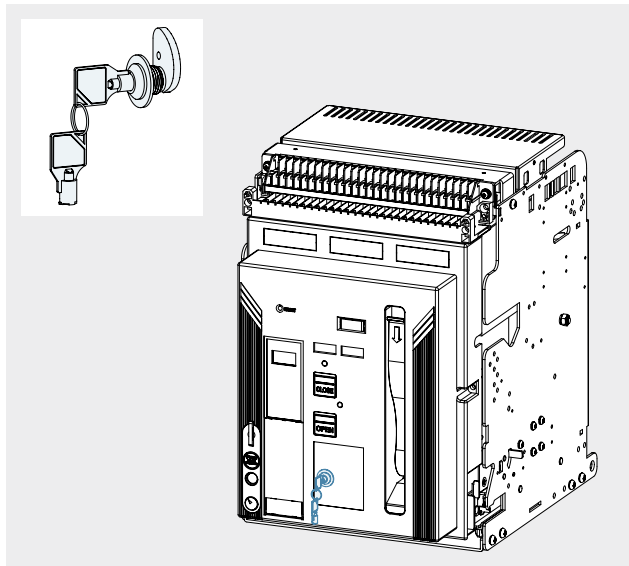

- The key lock prevents the circuit breaker closing, it maintains interlock condition (Mechanical prevention).
- When the key has been unlocked you can operate spring changing/manual on or off, when the key is removed from circuit breaker it becomes interlock. The key doesn't turn to lock position until user push the off button, when the key is locked.
- **Ordering code: AB, UANS AB (Spare part)**

| Key interlock |

- Configure the system with three breaker mounted key lock device. Only two breakers are possible for input with two separate keys and the other breaker is interlocked to supply stable load.

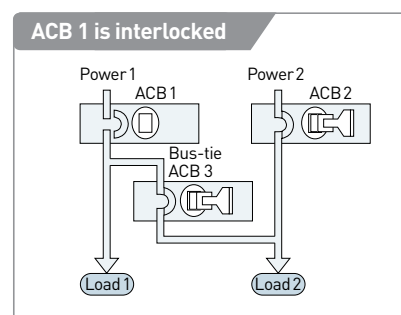
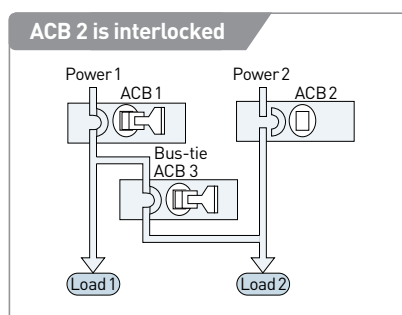
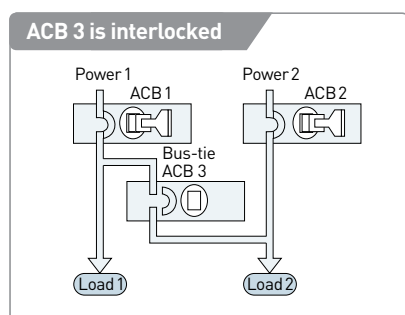

Accessories

| Miss-insertion preventer |

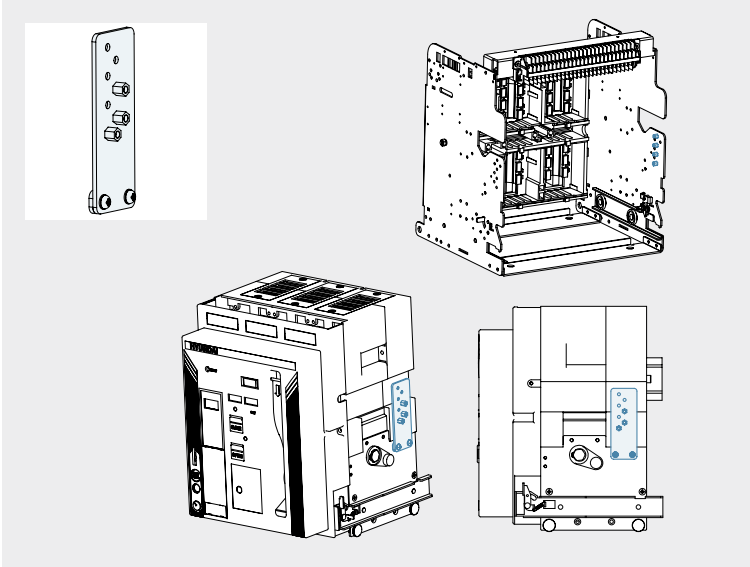

- When the main body of ACB is inserted to the cradle that does not match with the ratings of ACB, it mechanically prevents ACB from being inserted into cradle.
- Each part will have been installed on body or cradle.
- This device is set by CT rated current.
- Ordering code: AW (Attachment)
UANS AW (Accessory only)
- Add each ordering code to both body and cradle code.

■ Mounting position according to rated current

CT	Mounting position		CT	Mounting position	
	Cradle	ACB		Cradle	ACB
0 = Without OCR	ADEG	236	K = 1,250A	ABCF	457
I = 80A	AEFG	234	L = 1,600A	ABCE	467
B = 160A	ADFG	235	M = 2,000A	ABCD	567
O = 200A	ADEF	237	N = 2,500A	BCDE	167
V = 320A	ABEF	347	P = 3,200A	BCDF	157
E = 400A	ABDG	356	Q = 4,000A	BCDG	156
T = 630A	ABDF	357	S = 5,000A	BCEF	147
H = 800A	ABDE	367	X = 6,300A	ABEG	346
J = 1,000A	ABCG	456			

■ Mounting position according to rated current

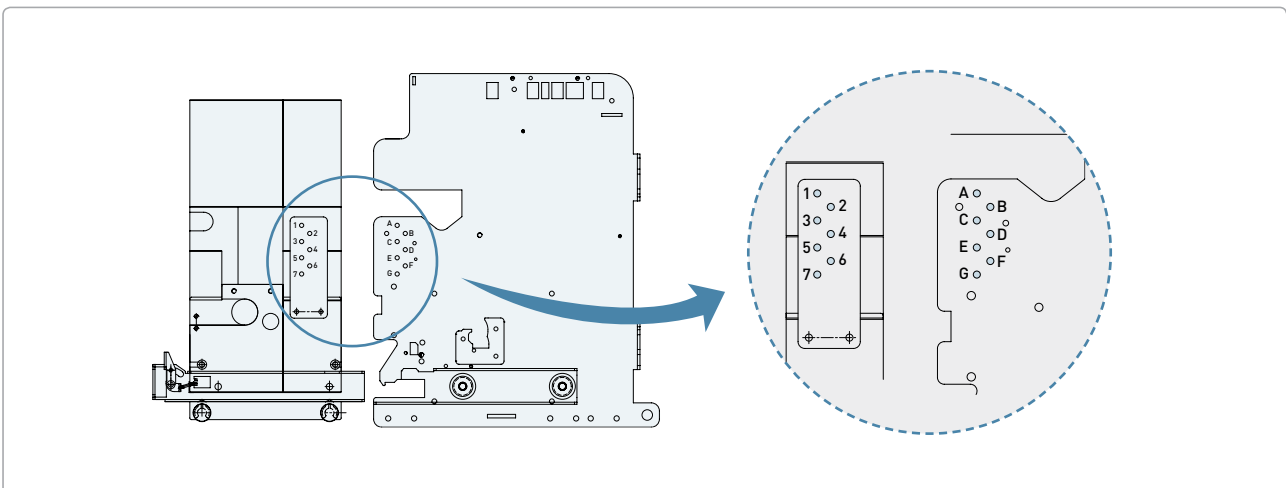

| OCR & Alarm switch reset |

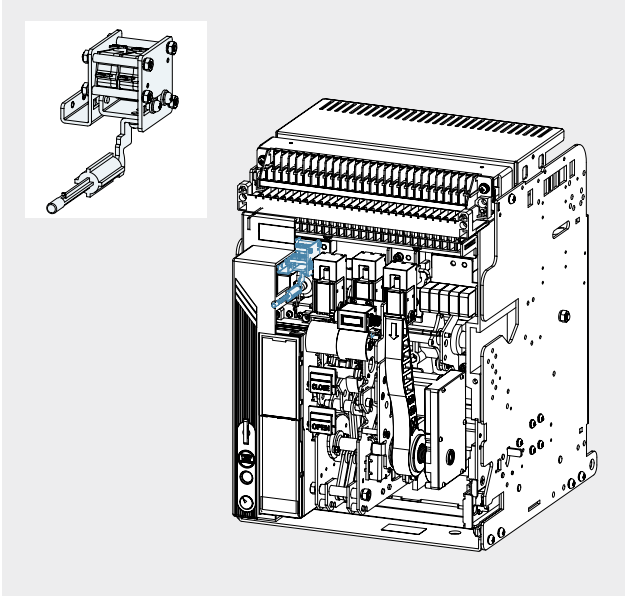

- When a circuit breaker tripped by fault current or over load and only if the circuit breaker has been tripped by OCR, the MRB operates interlock and resets the interlock to restore electric lines after fault factors have been removed. -(BR)
- When the CB is tripped by OCR it provides functions of interlocking above mechanism -(BR) and output contacts (2a) which check operation of CB by OCR as well. The output contact displays OCR operation by long time, short time delay, instantaneous and ground fault. And resetting above mechanism occurs. -(BA)
- Except above functions when emergent restoration of electric load is needed it automatically reset itself to get ready to open immediately after trip and reset only output contacts.(BH)
- When the CB is tripped by OCR, it provides functions of interlocking mechanism-(BR) and CB condition B shown by high-capacity output contact switch. This output contact is resetted manually.
- It will have been installed when the product is out. Add BR/BA/BH on your order.

■ Ordering code

Item	Ordering code		Specification	Application		Mounting position
	Complete parts of ACB/Cradle	Spare part		UAN	UAS	
OCR & Alarm switch reset Device	BR	UANS BR	for OCR manual reset only	<input type="radio"/>	<input type="radio"/>	Inside of ACB body
	BA	UANS BA	for OCR manual reset & Alarm switch reset	<input type="radio"/>	<input type="radio"/>	
	BH	UANS BH	for OCR manual reset & Alarm switch reset (DC3A)	<input type="radio"/>	<input type="radio"/>	

Accessories

| Safety shutter lock |

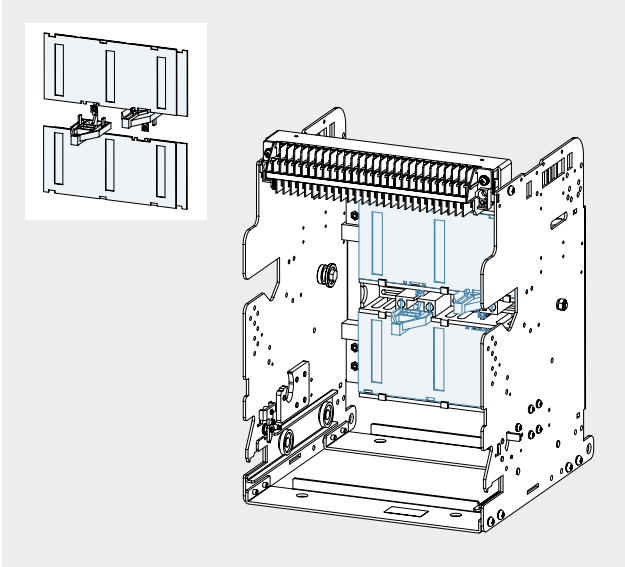

- An automatic safety device to protect the connectors of main circuit by cutting off dangerous contact from outside while the breaker is drawn out.
- Shutter lock is a locking device which prevents safety shutter from being opened when it is closed. (Key lock is not included. Size is $\phi 5 - \phi 8$)
- Shutter operates separately from power side and load side, so separate lock is possible and its operating mechanism is individual.
- When ordering, please include "AE" in the cradle order form.

■ Ordering code

Item	Ordering code		Specification	Application		Mounting position
	Complete parts of ACB/Cradle	Spare part		UAN	UAS	
Safety shutter lock	AE	UANS AEA3	for A frame, 630 - 2,000A, 3P	○	○	Inside of cradle
		UANS AEA4	for A frame, 630 - 2,000A, 4P	○	○	
		UANS AEB3	for B frame, 630 - 4,000A, 3P	○	○	
		UANS AEB4	for B frame, 630 - 4,000A, 4P	○	○	
		UANS AEC3	for C frame, 3,200 - 5,000A, 3P	○	○	
		UANS AEC4	for C frame, 3,200 - 5,000A, 4P	○	○	

| Arc shield |

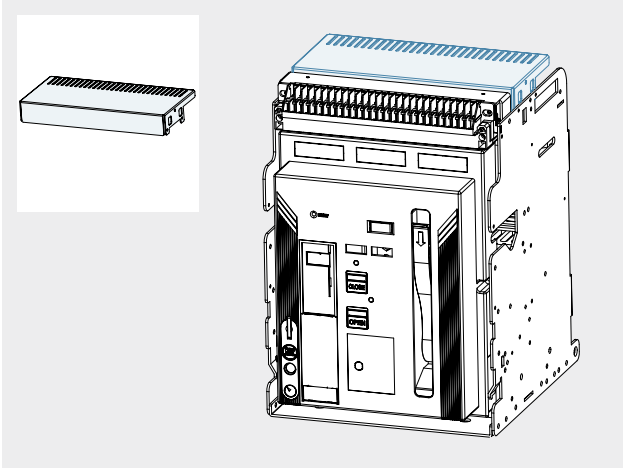

- Arc which may arise while breaking fault current is extinguished first by arc chute in main body of circuit breaker and then completely extinguished by arc cover.
- When using arc shield, the insulation distance due to arc fault can be reduced to "0".
- It also makes ACBs to be stored in 4 stories.
- When ordering, please add AX in the order form.

■ Ordering code

Item	Ordering code		Specification	Application		Mounting position
	Complete parts of ACB/Cradle	Spare part		UAN	UAS	
Arc shield	AX	UANS AXA3	for A frame, 630 - 2,000A, 3P	<input type="radio"/>	<input type="radio"/>	Upper side of cradle
		UANS AXA4	for A frame, 630 - 2,000A, 4P	<input type="radio"/>	<input type="radio"/>	
		UANS AXB3	for B frame, 2,000 - 4,000A, 3P	<input type="radio"/>	<input type="radio"/>	
		UANS AXB4	for B frame, 2,000 - 4,000A, 4P	<input type="radio"/>	<input type="radio"/>	
		UANS AXC3	for C frame, 4,000 - 5,000A, 3P	<input type="radio"/>	<input type="radio"/>	
		UANS AXC4	for C frame, 4,000 - 5,000A, 4P	<input type="radio"/>	<input type="radio"/>	

| Control terminal protection cover |

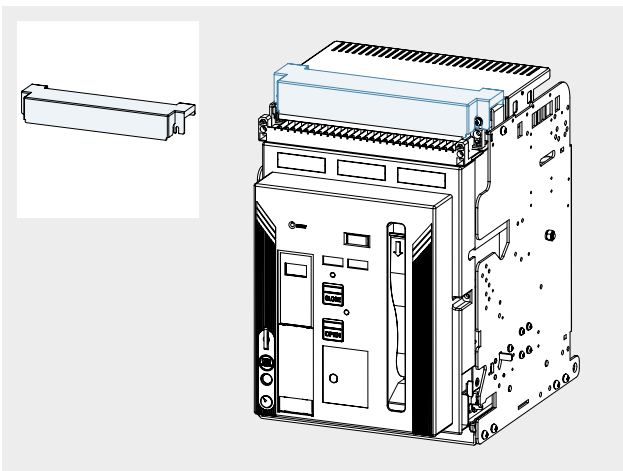

- Protects control terminals which are exposed to the outside, and prevent damage from foreign substances.
- Cannot be applied to fixed type ACB and draw-out type ACB with manual connection terminal.
- Not possible to install it both fix type and manual jack type.
- **Ordering code: BC (In case of auto-connection mode)**

■ Ordering code

Item	Ordering code		Specification	Application		Mounting position
	Complete parts of ACB/Cradle	Spare part		UAN	UAS	
Control terminal protection cover	BC	UANS BC	for auto connection control terminal	<input type="radio"/>	<input type="radio"/>	Control terminal of cradle

Accessories

| Control terminal |

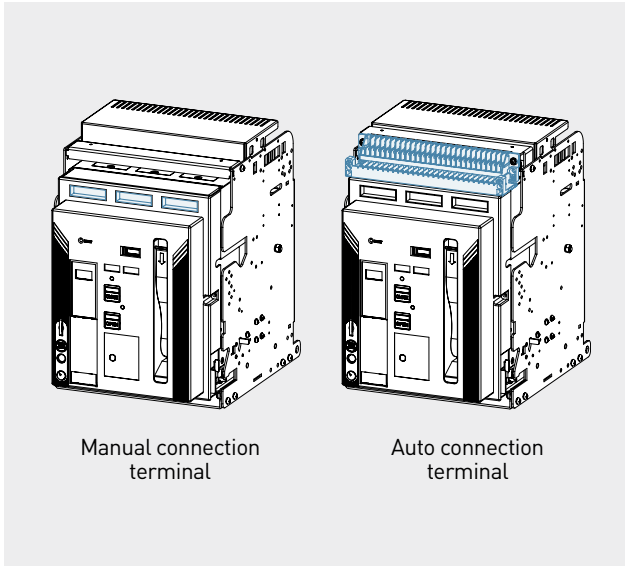

- Two types of connecting control power. Auto connection type which the body connected or isolated from control power automatically and manual connection type which the connector is inserted to the body manually.
- Fixed type is provided with manual control plug type as standard.
- Draw-out type's ordering code: "A" for auto connection, "J" for manual control plug type.
- When manual connection type to be completely drawn out from cradle, its connector should be removed before drawing out.

■ Ordering code

Item	Ordering code		Specification	Application		Mounting position
	Complete parts of ACB/Cradle	Spare part		UAN	UAS	
Control terminal	A	UANS CJ	Auto connection terminal	○	○	Inside of ACB body & cradle
	J	UANS MJ	Manual connection terminal	○	○	

| Short "b" contact |

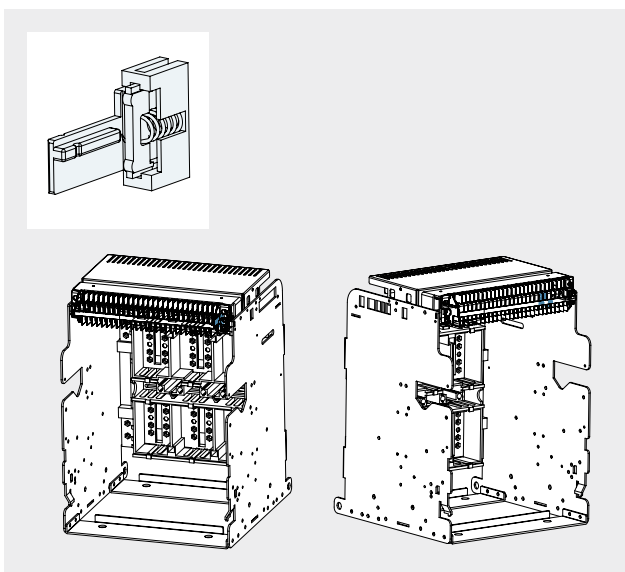

- A contact which keeps the external control circuit in normal by auxiliary contact which disconnects AUX "b" when ACB is moved from connected position to test position.
- The number of "Shorting "b" contact" corresponds to the number of AUX "b" (5b).
- **Ordering code: AK, UANS AK (Spare part)**

ACB operating ACB position	ACB close (AUX "b" off)	ACB open (AUX "b" on)
Connected position (Short "b" off)	<div style="text-align: center;">Off</div>	<div style="text-align: center;">On</div>
Test position (Short "b" on)	<div style="text-align: center;">Off</div>	<div style="text-align: center;">On</div>

| Fixing block |

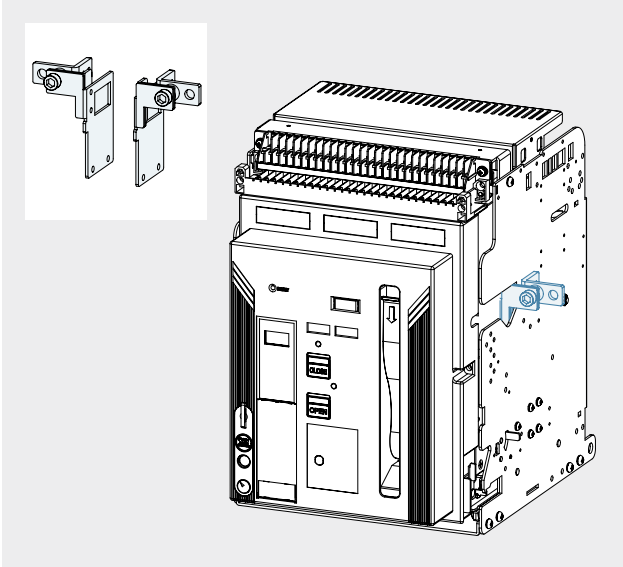

- The fixing block can reinforce safety gear to prevent malfunctioning from vibration.
- Able to strengthen bodies, cradles, and panel supporter together.
- ACB and its cradle is delivered with each fixing block installed.
- Add AF on main body of ACB and cradle's order respectively.

■ Ordering code

Item	Ordering code		Specification	Application		Mounting position
	Complete parts of ACB/Cradle	Spare part		UAN	UAS	
Fixing block	AF	UANS AF	for ACB body and cradle	<input type="radio"/>	<input type="radio"/>	Outside of ACB body & cradle
		UANS AFB	for ACB body	<input type="radio"/>	<input type="radio"/>	
		UANS AFC	for cradle	<input type="radio"/>	<input type="radio"/>	

| Counter |

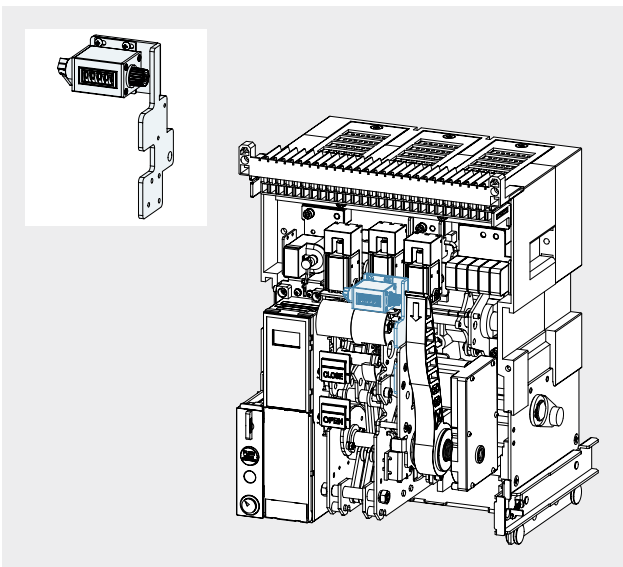

- Displays the total number of on/off operation of ACB
- The counter displays the total number of on/off operation of ACB.
- Extra order is unnecessary (It is a primary component of UAN/UAS).
- Ordering code: UANS AD (Spare part)

Accessories

| Remote operation & Temperature detection module |

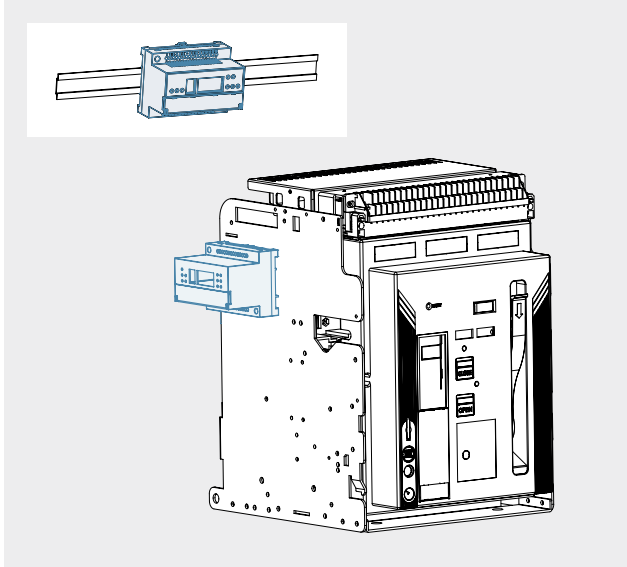

- Installed on the cradle or inside of panel, and communicates with Modbus/RS-485 basically.
- Needs to be purchased separately and can be operated with temperature alarm unit at the same time.
- Please refer to page 47 for temperature sensor.

■ Contact specification

	Division	Range of application
ACB control	Contact ratings	10A 240VAC, 30VDC
	Max switching power	2,400VA, 300W

| Temperature detection module |

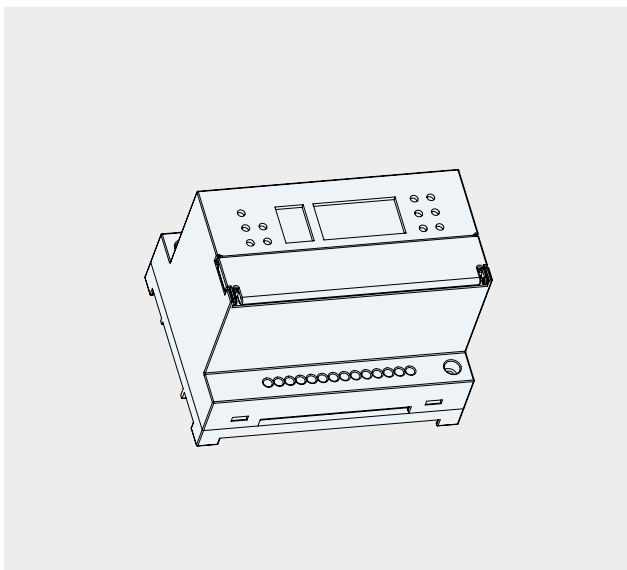

- Temperature alarm unit is a device to show the busbar's temperature through a sensor inside of ACB.
- Temperature sensor can be installed up to 3ea and alarm can occur when it reaches the specified temperature.
- Display the maximum temperature on the segment LED and transmits through a network.
- Communicates with modbus/RS-485 basically, and needs to be purchased separately.
- Installed on the cradle or inside of panel, and can be operated with remote closing & trip unit at the same time.

■ Contact specification

	Division	Range of application
Temperature alarm	Contact ratings	10A 120VAC/5A 240VAC 5A 30VDC
	Max switching power	1,200VA, 150W

| Temperature sensor |

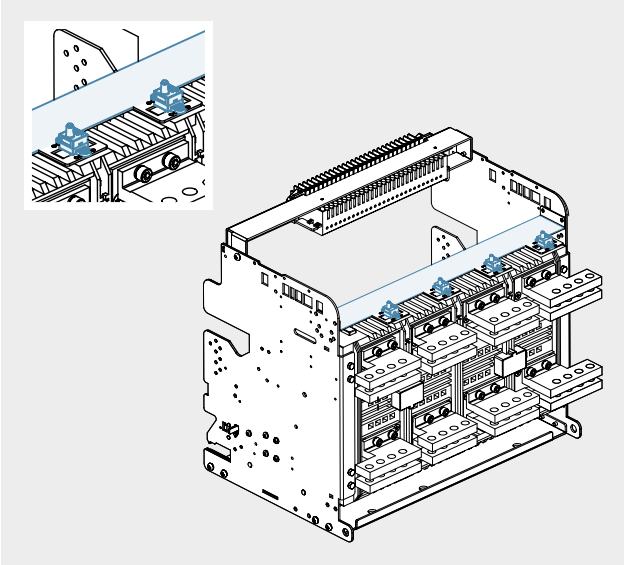

- The RCTU is used with temperature sensor installed inside of the ACB.
- The temperature sensor is installed in designated position. However user can change the position to applicable extra site.

■ Ordering code

Item	Ordering code		Specification	Application		Mounting position
	Complete parts of ACB/Cradle	Spare part		UAN	UAS	
Temperature sensor	-	UANS TSN	Temperature sensor	○		Inside of cradle

Accessories

Remote control temperature unit

- RCTU has Digital Output contact that ables remote insertion/disconnection of ACB by communication. It checks temperature of ACB with 4 temperature channels.
- RCTU communication offers RS-485/Modbus-RTU.
- Insertion/disconnection control of ACB assures its reliability through SBO (select before operation) function.
- If the temperature rises over the user setting value, you can check it through alarm contacting point (additional connection needed).
- You can check ACB temperature through segment LED at the front.
- RCTU can be installed in side of the ACB cradle or panel.
- RCU module has same function as RCTU module except for the temperature monitoring.

Contact(DO) specification

	Type	Range
ACB control	Contact ratings	10A 240VAC, 30VDC
	Max switching power	2,400VA, 300W
Temperature alarm	Contact ratings	10A 120VAC/5A 240VAC/5A 30VDC
	Max switching power	1,200VA, 150W

Shape

	Status LED	Information
RCTU	Run LED	RCTU running LED
	Com LED	Communication LED
	Temp. Alarm LED	Temp. Alarm LED
	Alarm DO LED	Temp. Alarm DO LED
General digital input	DI 1	Dry contact(5V)
	DI 2	Dry contact(5V)
ACB control	CB Cloes	ACB close LED
	CB Open	ACB open LED
	CB Error	ACB close/open terminal disconnection & controlling error

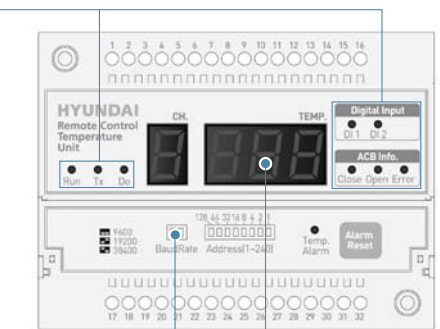

Communication setting Temperature signal

IR sensor measurement

- IR sensor should be installed in appropriate distance between sensor and measuring point.
- Recommended distance is 50-80mm.
- Measuring point should be reflectionless surface and we recommend painting it with matt black paint for the nature of IR sensor.

CAUTION

1. IR sensor differs value by the reflectivity of metal surface. Measuring point should be varnished or painted with matt black paint depending on material.
2. Measuring point and IR distance differs measuring spot size by D:S ratio. This sensor has 8:1 scale.

| Draw-in/out device unit & Position lock device |

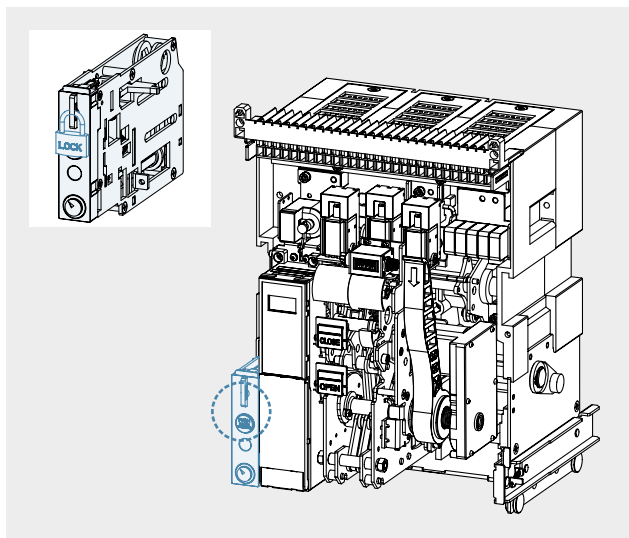

- Draw-in/out device unit is mounted on the body of draw type ACB as standard.
- Draw-in/out device unit consists of draw-in/out handle storage space, push button, position indicator, pad lock.
- Position pad lock is a safety device as locking draw-in/out function in connected/test/sol position.
- This device is offered as standard except key lock.
Available key lock size: $\phi 5 - \phi 8$
- **Ordering code: UANS DR (Spare part)**

| Draw-in/out handle |

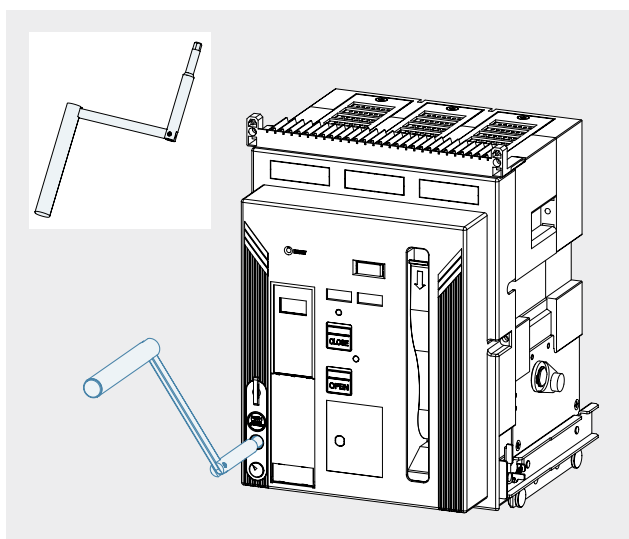

- Draw-in/out handle is attached on the side of cradle as standard.
- **Ordering code: UANS L handle or UANS U handle**

■ UANS L handle

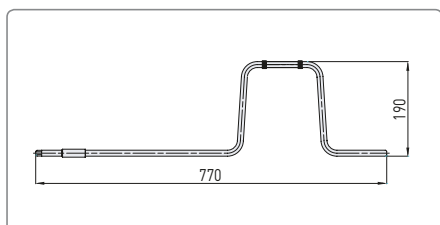

■ UANS U handle

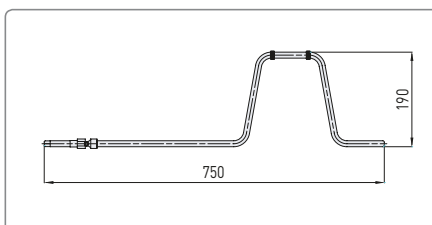

■ T-type handle

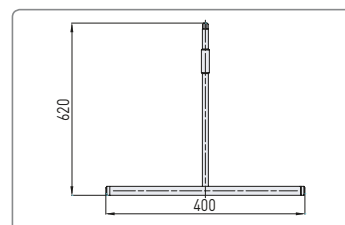

■ Ordering code

Item	Ordering code		Specification	Application		Mounting position
	Complete parts of ACB/Cradle	Spare part		UAN	UAS	
Draw-in/out handle	-	UANS HANDLE	Standard type	○	○	-
	-	UANS LHANDLE	Long type	○	○	
	-	UANS UHANDLE	Universal joint type	○	○	
	-	UANS THANDLE	T-type	○	○	

Accessories

| Neutral CT |



- The NCT is additionally applied for 3-pole circuit breaker when it is connected to distribution line (3 phases 4 lines).
- For distribution line (3 phases 4 lines) 3pole circuit breaker can protect the ground fault. However, we can not classify unbalanced load and ground fault. To complement this when only a ground fault occurs the NCT senses the N phase load and operates the GFT.
- When connecting a relay or electric instrument checking phase is mandatory. Please connect the designated terminal.
- It is a separate product. Refer to the table below (Rated current level) and check the item on your order.

■ Ordering code

Item	Ordering code	Specification
Neutral CT	UANS NCT_T	NCT T = 630A/Inner Diameter 80
	UANS NCT_H	NCT H = 800A/Inner Diameter 80
	UANS NCT_J	NCT J = 1,000A/Inner Diameter 80
	UANS NCT_K	NCT K = 1,250A/Inner Diameter 80
	UANS NCT_L	NCT L = 1,600A/Inner Diameter 80
	UANS NCT_M	NCT M = 2,000A/Inner Diameter 135
	UANS NCT_N	NCT N = 2,500A/Inner Diameter 135
	UANS NCT_P	NCT P = 3,200A/Inner Diameter 135
	UANS NCT_Q	NCT Q = 4,000A/Inner Diameter 200
	UANS NCT_S	NCT S = 5,000A/Inner Diameter 200
	UANS NCT_X	NCT X = 6,300A/Inner Diameter 200

■ Dimension

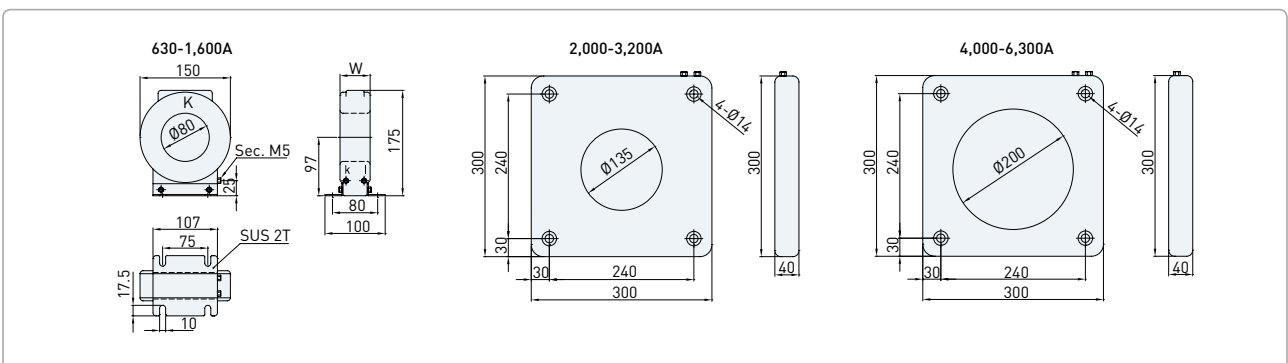

| Door flange |

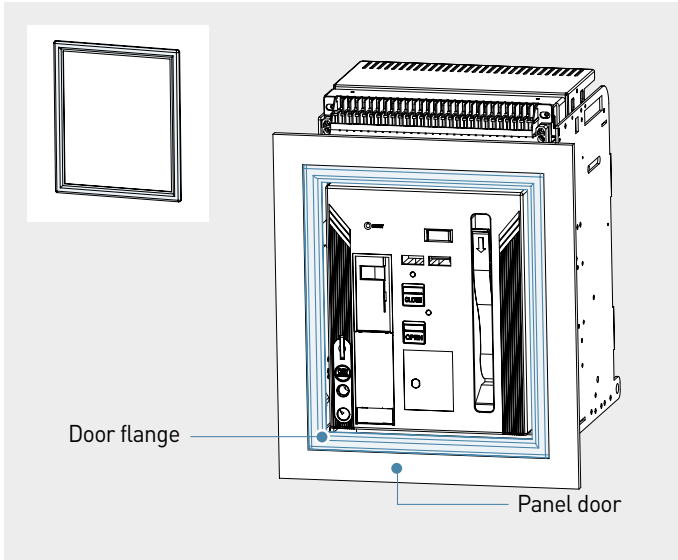

- Protects the protruding front of ACB and the cutting side of panel door by attaching it to the panel door.
- Both fixed/draw-out type are the same size of the panel cutting, even if the dust cover is installed.
- Refer to dimension for panel cutting size.
- Protection rating of IP30.

■ Panel door cutting dimensions

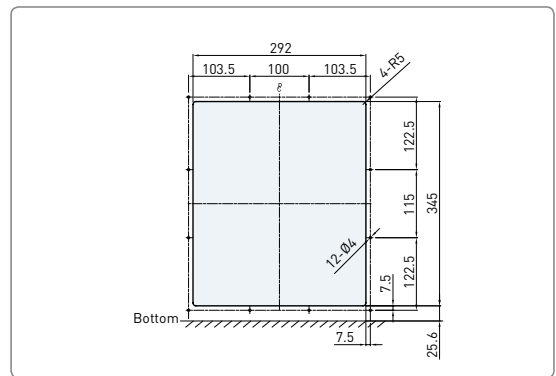

■ Ordering code

Item	Ordering code		Specification	Application		Mounting position
	Complete parts of ACB/Cradle	Spare part		UAN	UAS	
Door flange	-	UANS AG	for IP30	○	○	Panel door

| Dust cover |

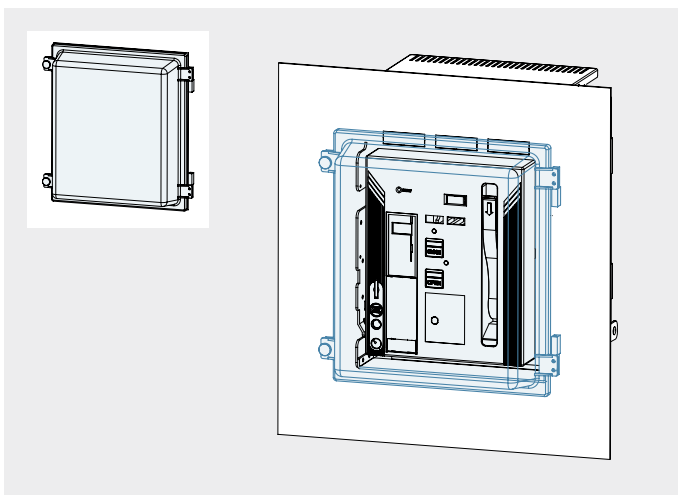

- A protective cover which completely protects the front panel of ACB from dust and moisture, with a protection rating of IP52.
- Locks the cover in the test or connected position.
- Refer to dimension for panel cutting size.

■ Panel door cutting dimension

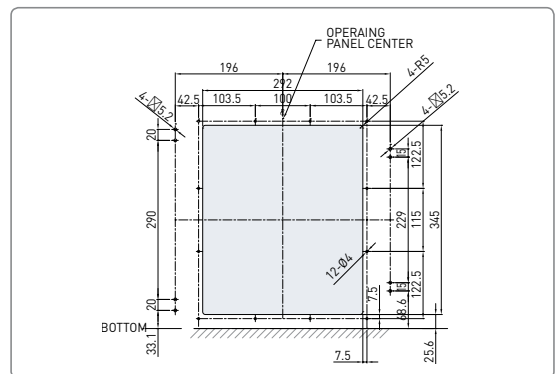

■ Ordering code

Item	Ordering code		Specification	Application		Mounting position
	Complete parts of ACB/Cradle	Spare part		UAN	UAS	
Dust cover	-	UANS DC	for IP52	○		-

Accessories

| Automatic transfer switch & Controller |

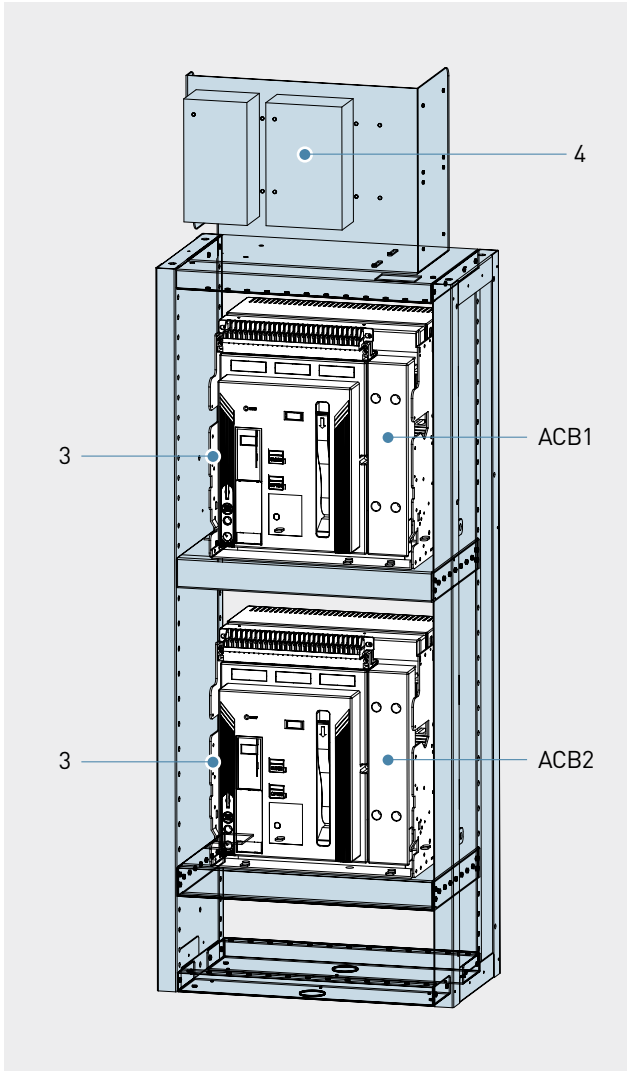

■ Features

- **Stable transfer system**
Provides definite protection for electric power system by using Hyundai ACB which has the highest breaking capacity.
 - **An unmanned working system**
An unmanned automatically transferring system is realized by installing auto power control device to the ACB with mechanic interlock device.
 - **Various mode**
Offers four selection modes for user's convenience.
 - **Multi protection device**
Multi protection device installed in ACB has various protecting functions such as self-monitoring, simple set up. Unlike existing ATS, it has overload protection to offer stable use.
 - **Compact size · Light weight**
ACB is more compact and lighter. It is easily installed in switchgear and occupies less space.
 - **ATS configuration and interlock**
 - ACB1: "Normal" power (First order side, UN)
 - ACB2: "Stand-by" power (Power generator side, UR)
 - 3 : Mechanical interlock device unit
 - 4 : ATS unit
- Each ACB should meet the following specifications.
- Mechanism of geared motor
 - TC
 - CC
 - Overload or short protection device

• Interlock conditions

ACB1	ACB2
Open	Open
Close	Open
Open	Close

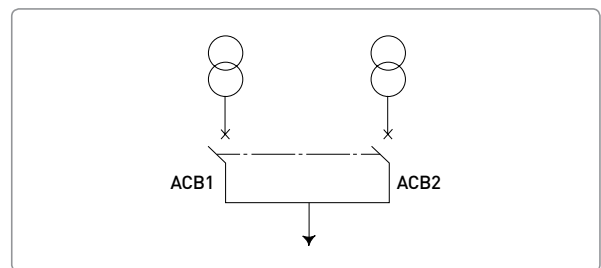

■ Ordering code

Item	Ordering code		Specification	Application		Mounting position
	Complete parts of ACB/Cradle	Spare part		UAN	UAS	
ATS controller	-	UANS ATS	Automatic transfer switch & controller	○		-

| Automatic transfer switch & Controller |

■ Description of mode

• **Stop mode**

This mode is for compulsory trip of ACB1 (Electric power company) or ACB2 (Power station) when UN (Power supply of electric power company) or UR (Power supply of power station) is available.

• **Auto mode**

This mode is for transferring a circuit breaker automatically to available power supply of UN or UR.

• **N mode**

This mode is for compulsory closing of ACB1 when UN is available.

• **R mode**

This mode is for compulsory closing of ACB2 during the use of UR regardless of that UN is available or not.

Time delay	State display of controller
t1: 0.1 - 30 sec t2: 0.1 - 240 sec	On, Off, Fault

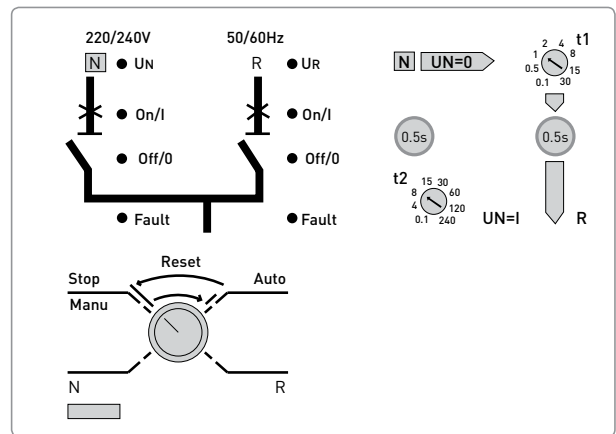

■ Operation characteristic

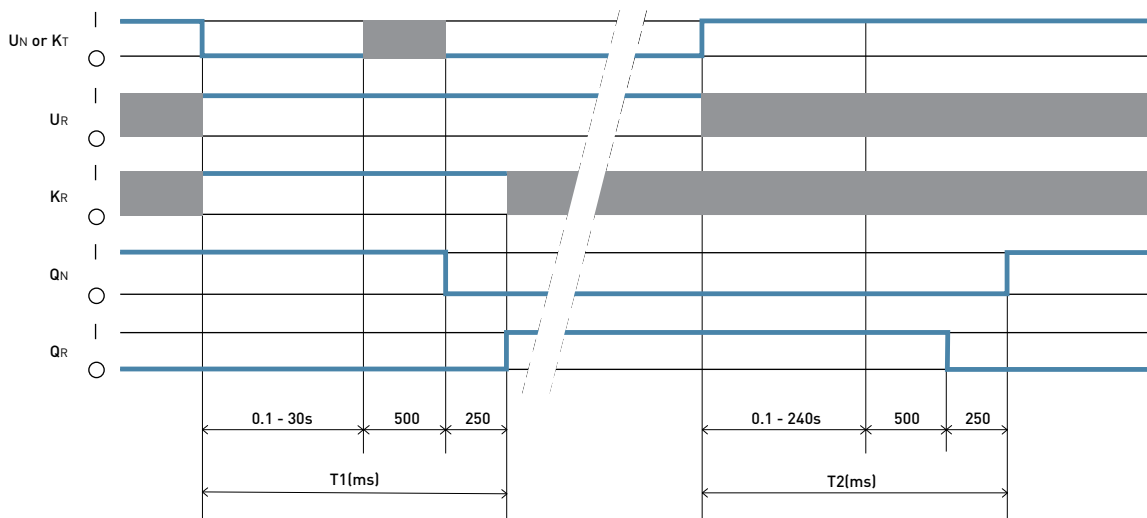

- UN: Normal power
- UR: Stand-by power
- KR: Re-checking
- QN: Normal power cut-off
- KR: Control signal for compulsory stand-by power
- QR: Stand-by power cut-off
- ■: On/Off

Accessories

System operation

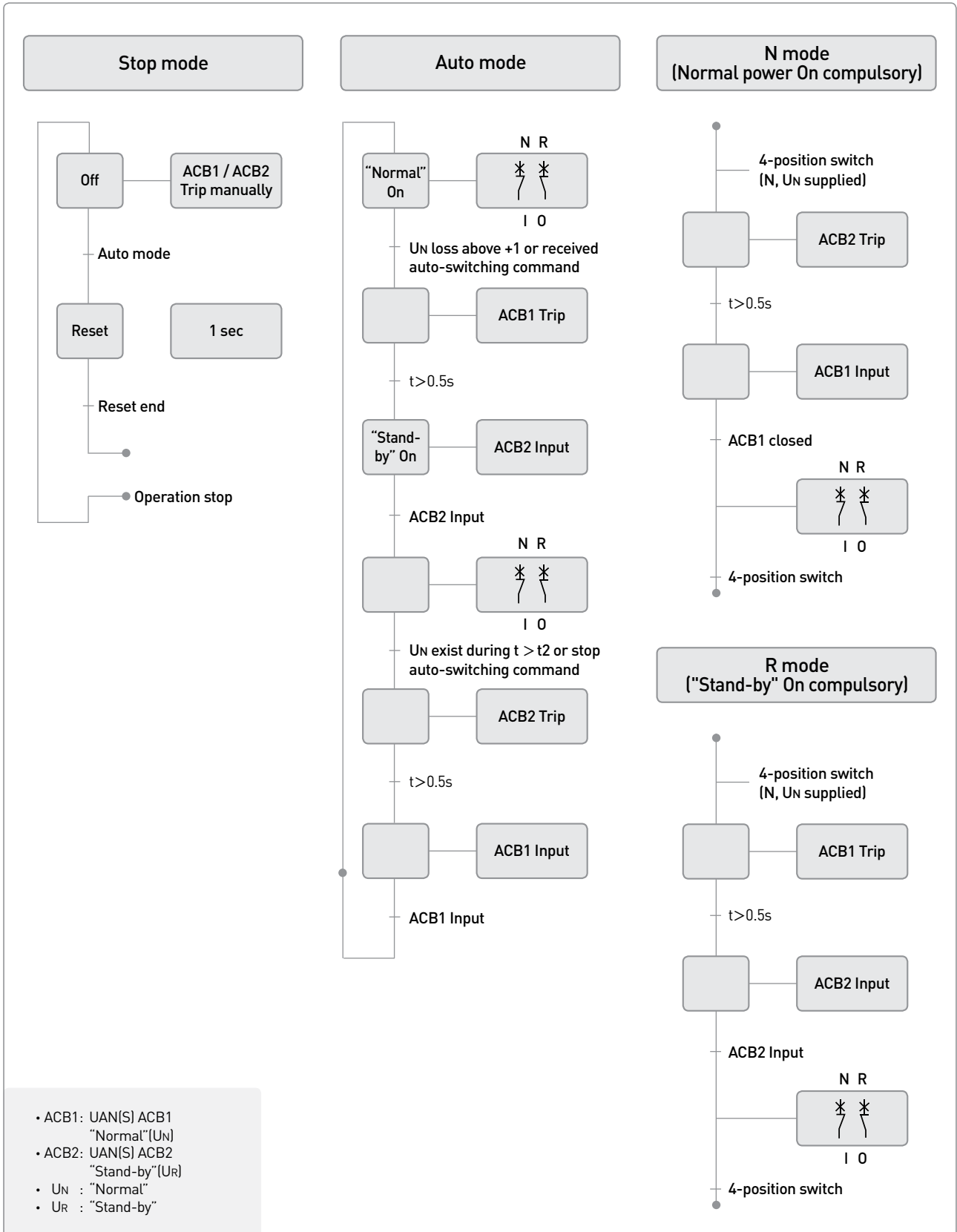

Accessories

| Automatic transfer switch & Controller |

■ Description of mode [UAN, UAS type]

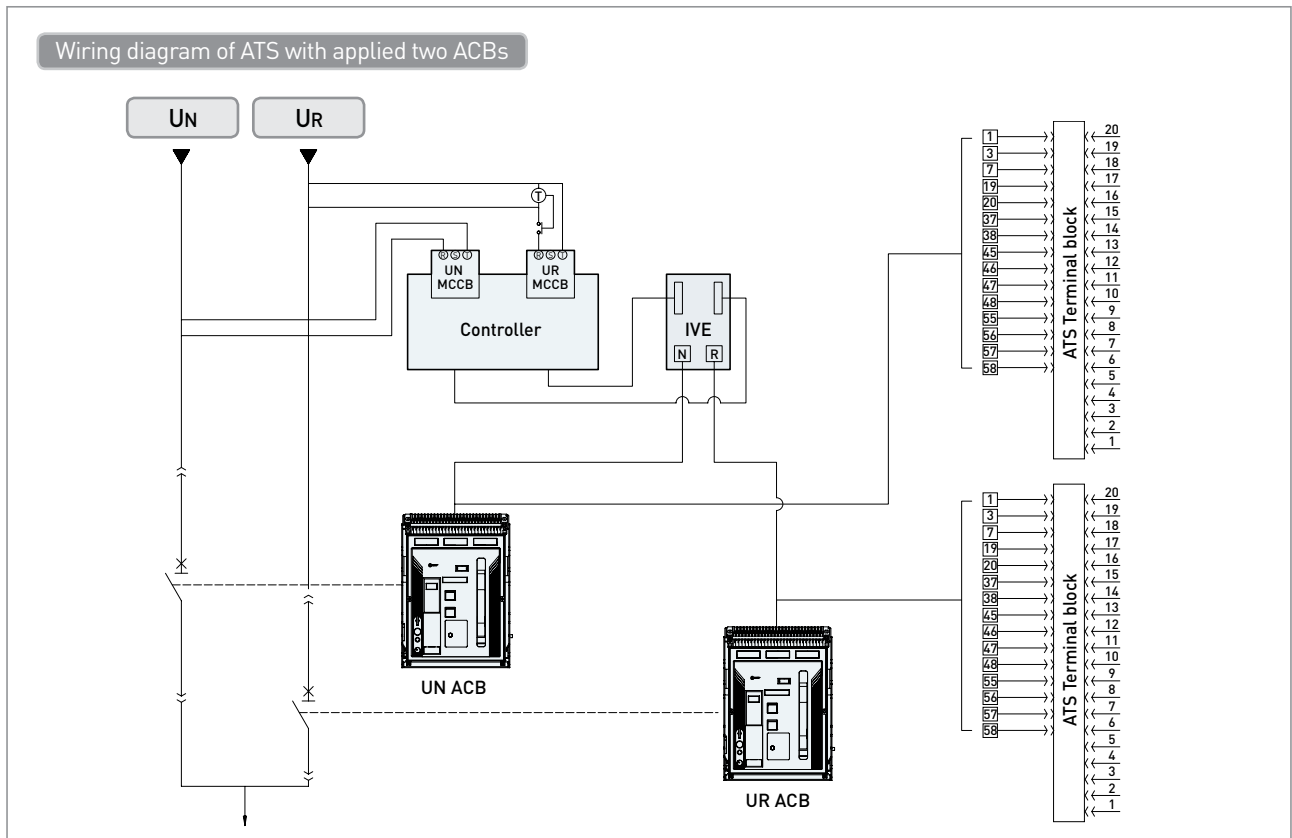
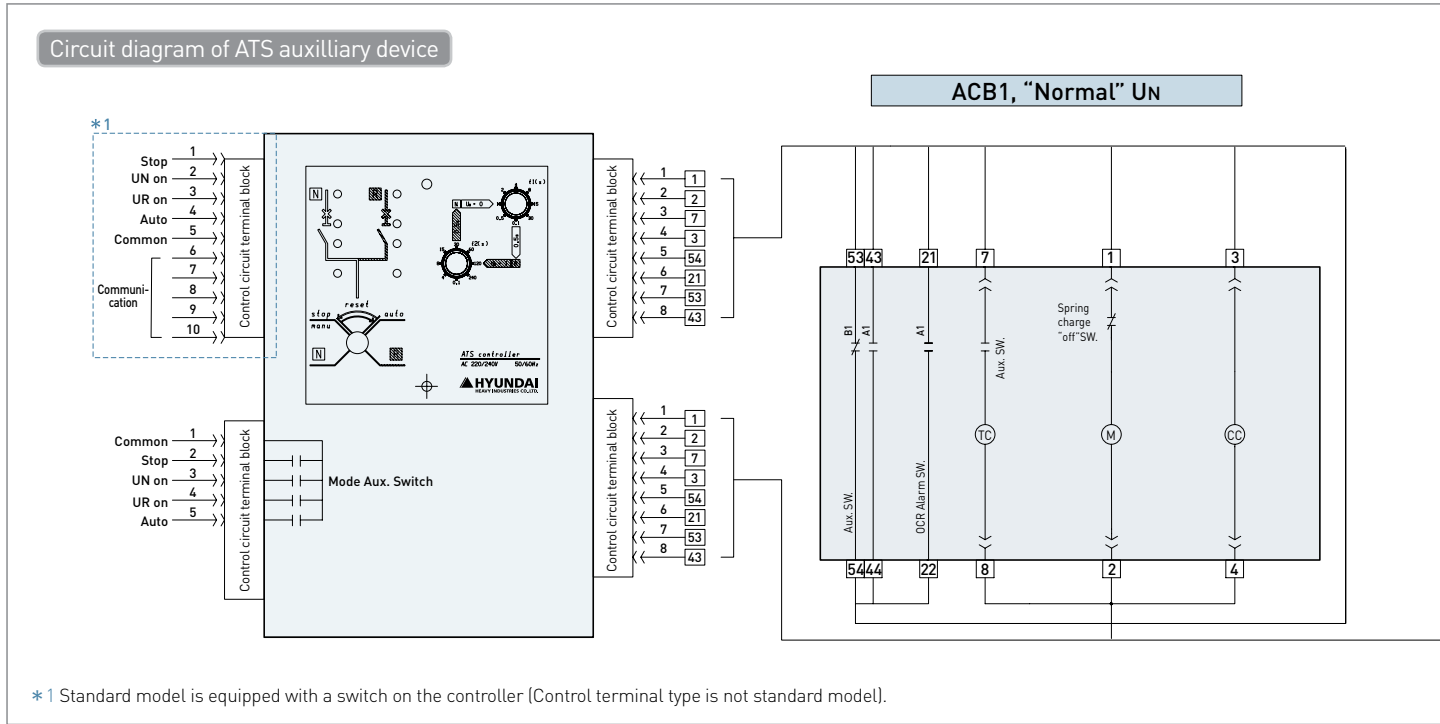

ACB2, "Stand-by" UR

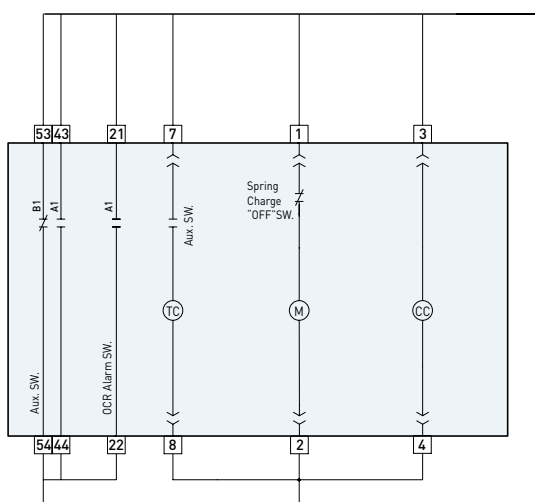

- 21|22 OCR DO
- 43|44 Aux. switch a
- 53|54 Aux. switch b
- TC Voltage trip
- 7|8 Shunt trip power terminals
- 1|2 Spring charge power terminals
- 3|4 Close power terminals
- M Charging motor
- CC Latch release (Close)

Wiring diagram of ATS panel remote

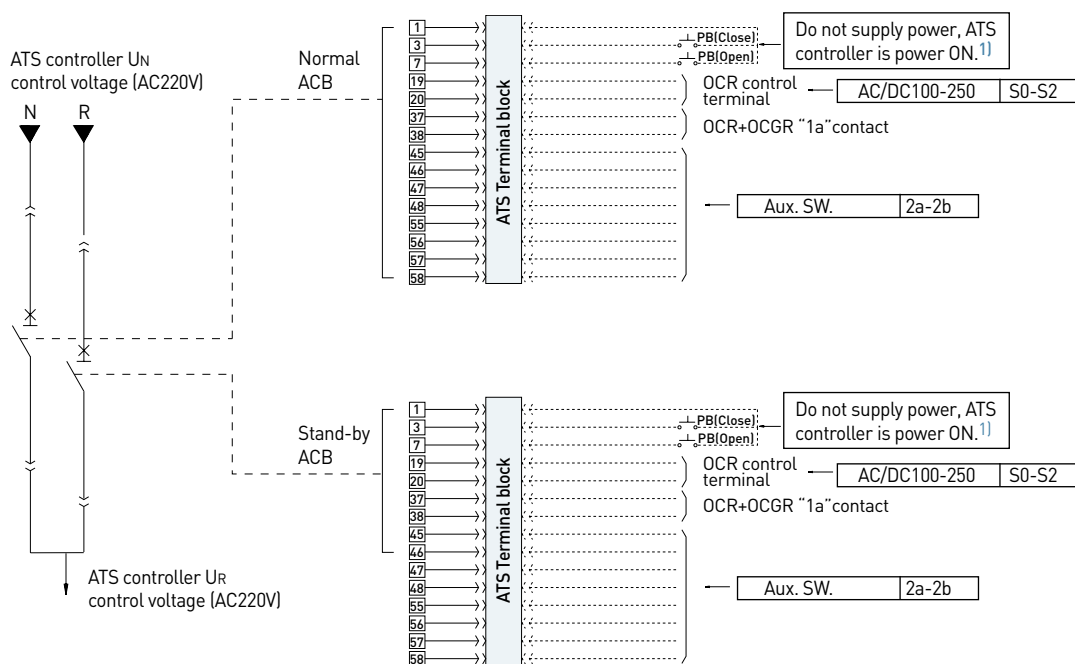

※ 1) Do not supply additional control power in case of operating remote, open/close power is supplied from ATS controller [Terminal No. "1", "7", "16"].

Accessories

| Automatic transfer switch & Controller |

■ Dimensions

(unit: mm)

UAN(S)06 - 16 A frame

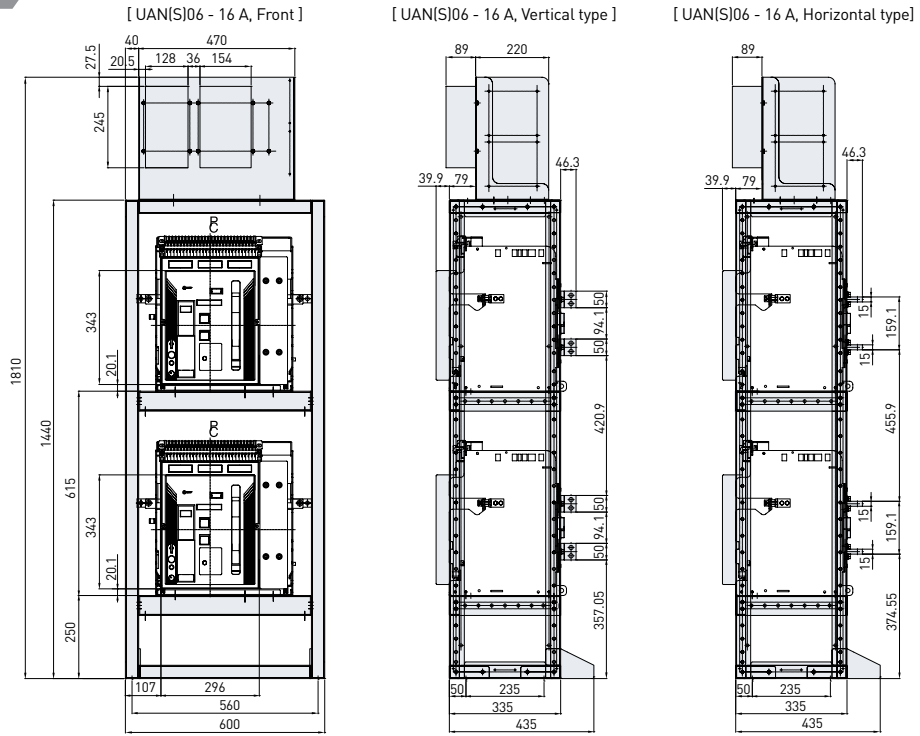

UAN20 A frame

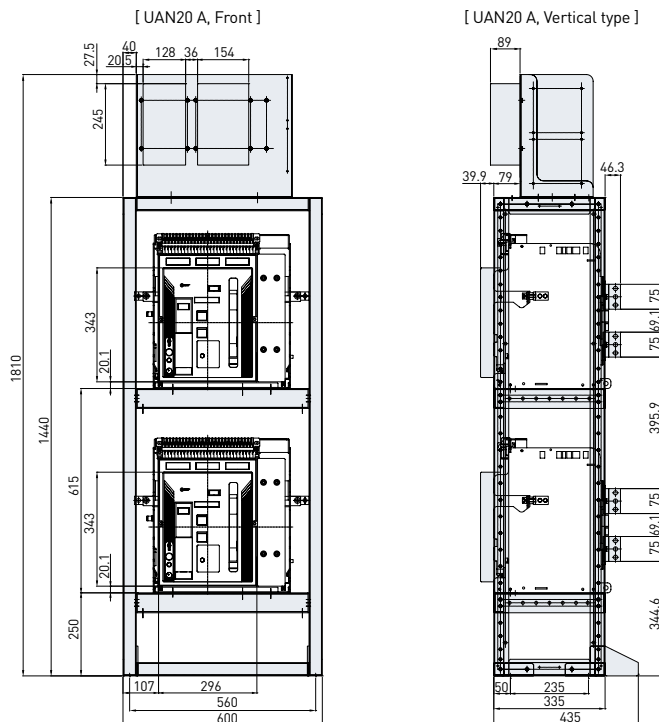

(unit: mm)

UAN(S)20 - 25 B frame

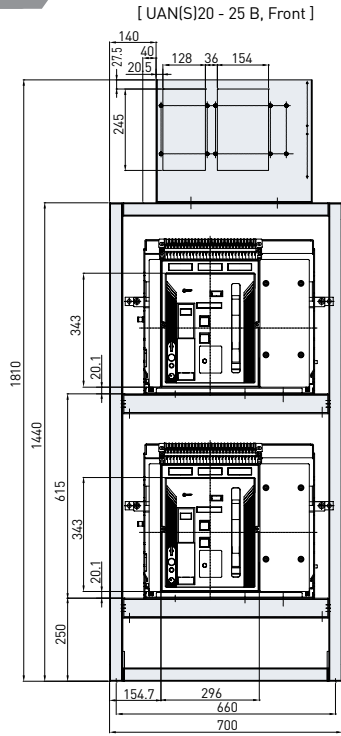

[UAN(S)20 - 25 B, Vertical type]

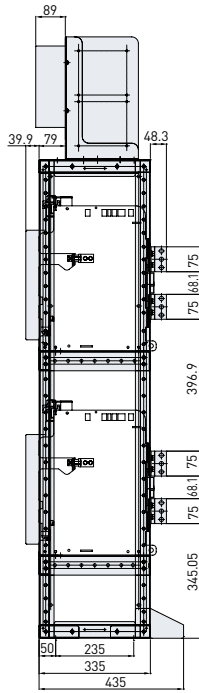

[UAN(S)20 - 25 B, Horizontal type]

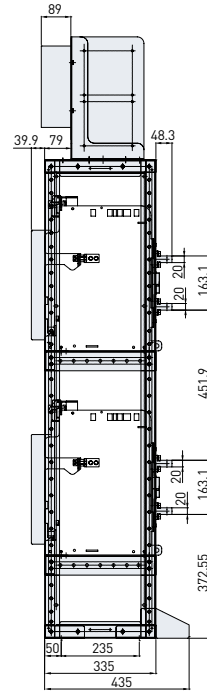

UAN(S)32 B frame

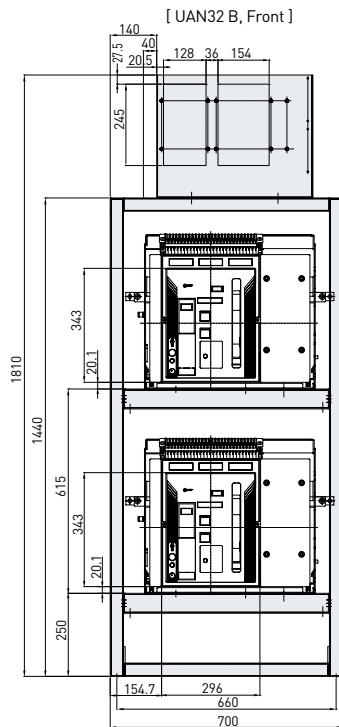

[UAN32 B, Vertical type]

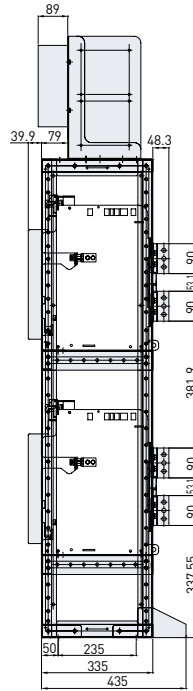

[UAN32 B, Horizontal type]

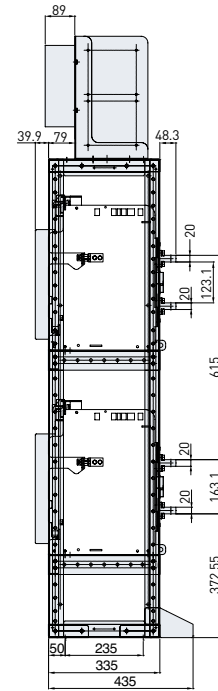

Accessories

| Automatic transfer switch & Controller |

■ Dimensions

(unit: mm)

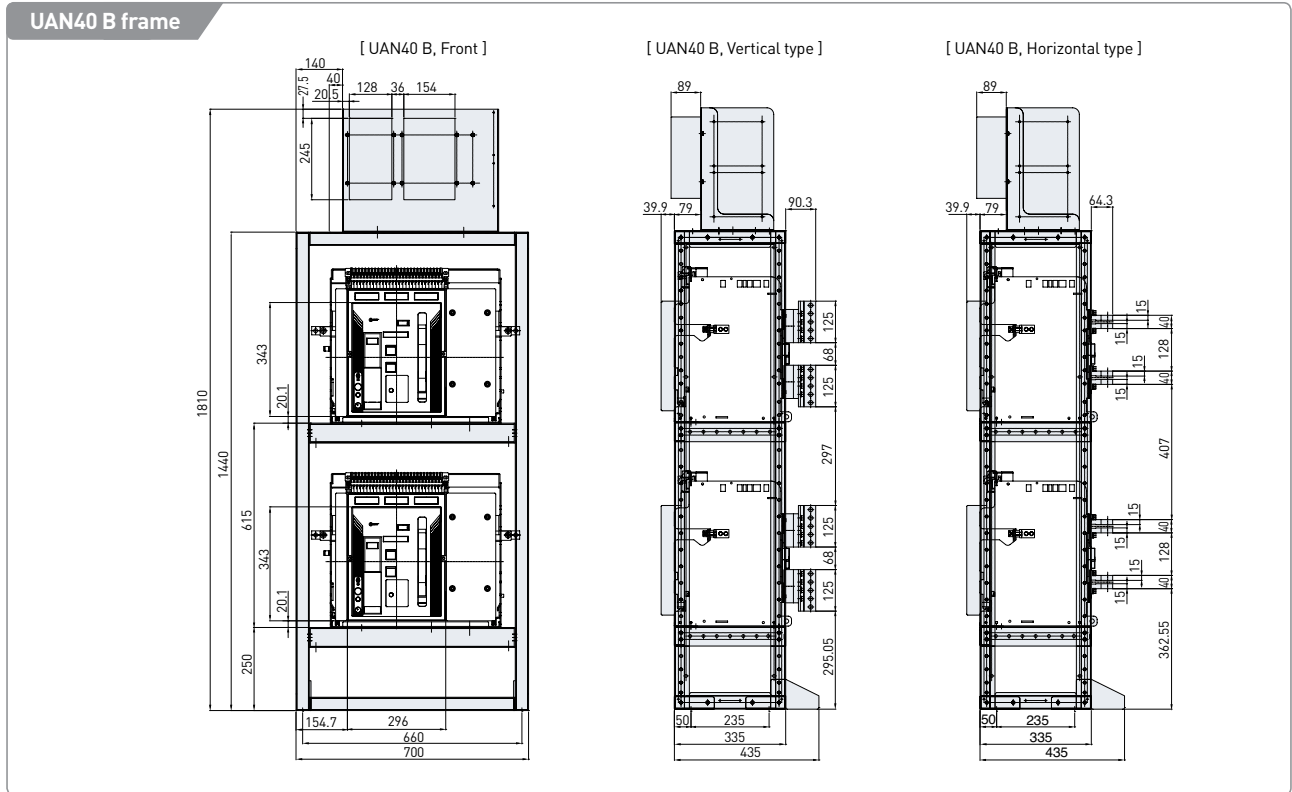

(unit: mm)

UAN40 - 50 C frame, 3P

[UAN40 - 50 C, 3P, Front]

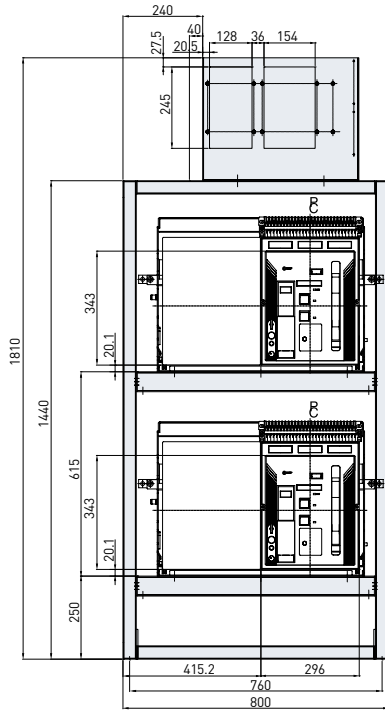

[UAN40 - 50 C, 3P, Vertical type]

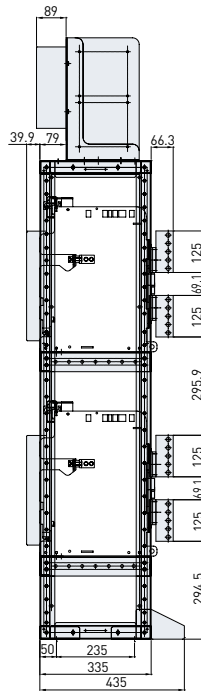

[UAN40 - 50 C, 3P, Horizontal type]

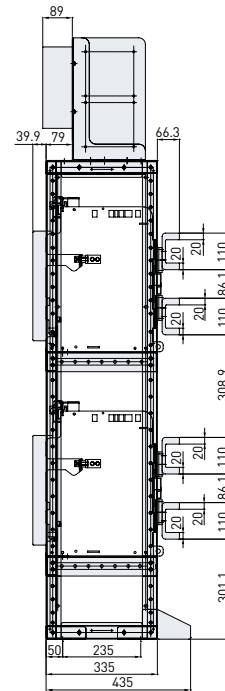

UAN40 - 50 C frame, 4P

[UAN40 - 50 C, 4P, Front]

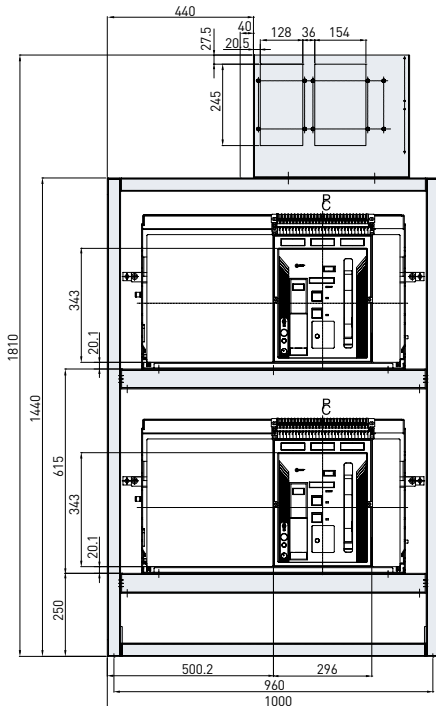

[UAN40 - 50 C, 4P, Vertical type]

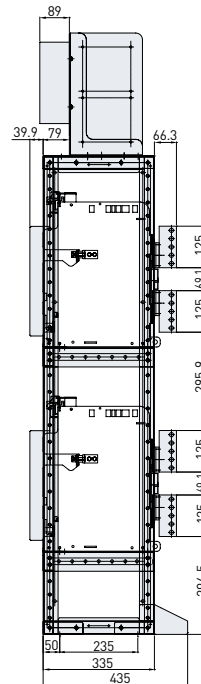

[UAN40 - 50 C, 4P, Horizontal type]

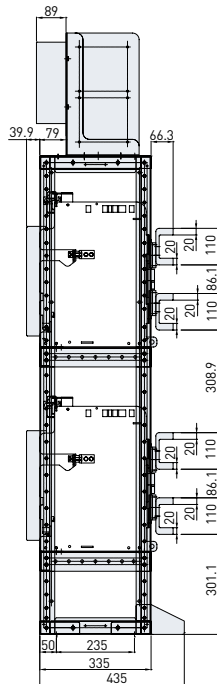

Circuit Diagrams

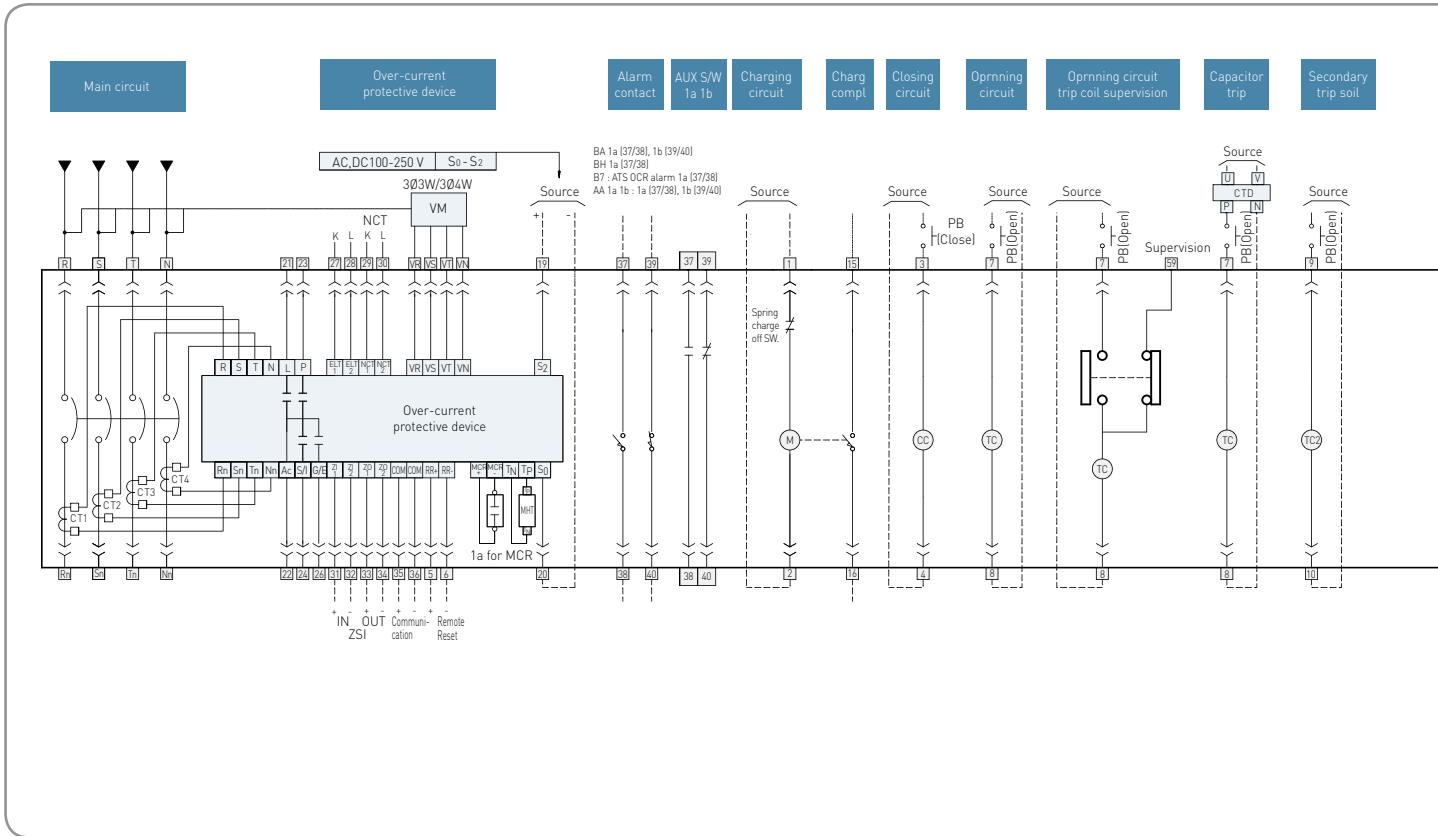

■ Symbol description

CT	Current transformer
L	LTD terminal
P	PTA terminal
G/E	GFT/ELT terminal
S / I	STD/INST terminal
Ac	Common terminal
ELT	Earth leakage trip
NCT	Nutral current transformer
ZI	Zone selective input
ZO	Zone selective output
COM	Communication (pc)
A/C	MCR input terminal
Tp/Tn	MHT input source
M	Charging motor
CC	Close coil (close)
TC	Trip coil (open)
TCS	Trip coil & supervision
TC2	Secondary trip coil (open)
UVT	Under voltade trip coil
MHT	Magnetic hold trigger
So/S2	OCR source power

■ Terminal description

1	2	Charging motor (M) source power
3	4	Closing coil (CC) source power
5	6	Remote reset
7	8	Opening coil (TC) source power
9	10	UVT coil econdary trip coil
15	16	Charge complete contact
19	20	OCR source power
22	21	LTD contact
22	23	TA/TEMP contact
22	24	STD/INST contact
22	26	GFT/ELT contact
27	28	ELT (CT/ZCT) input terminal
29	30	NCT input terminal
31 - 34		ZSI input/output
35	36	communication (RS485)
37 - 39		Alarm contact or AUX S/W 1a 1b
VN - VT		Voltage module
41 - 60		AUX contact
61 - 96		Position switch

- Manufacturer's wiring
- User's wiring
- << Disconnecting device (Draw-out type)

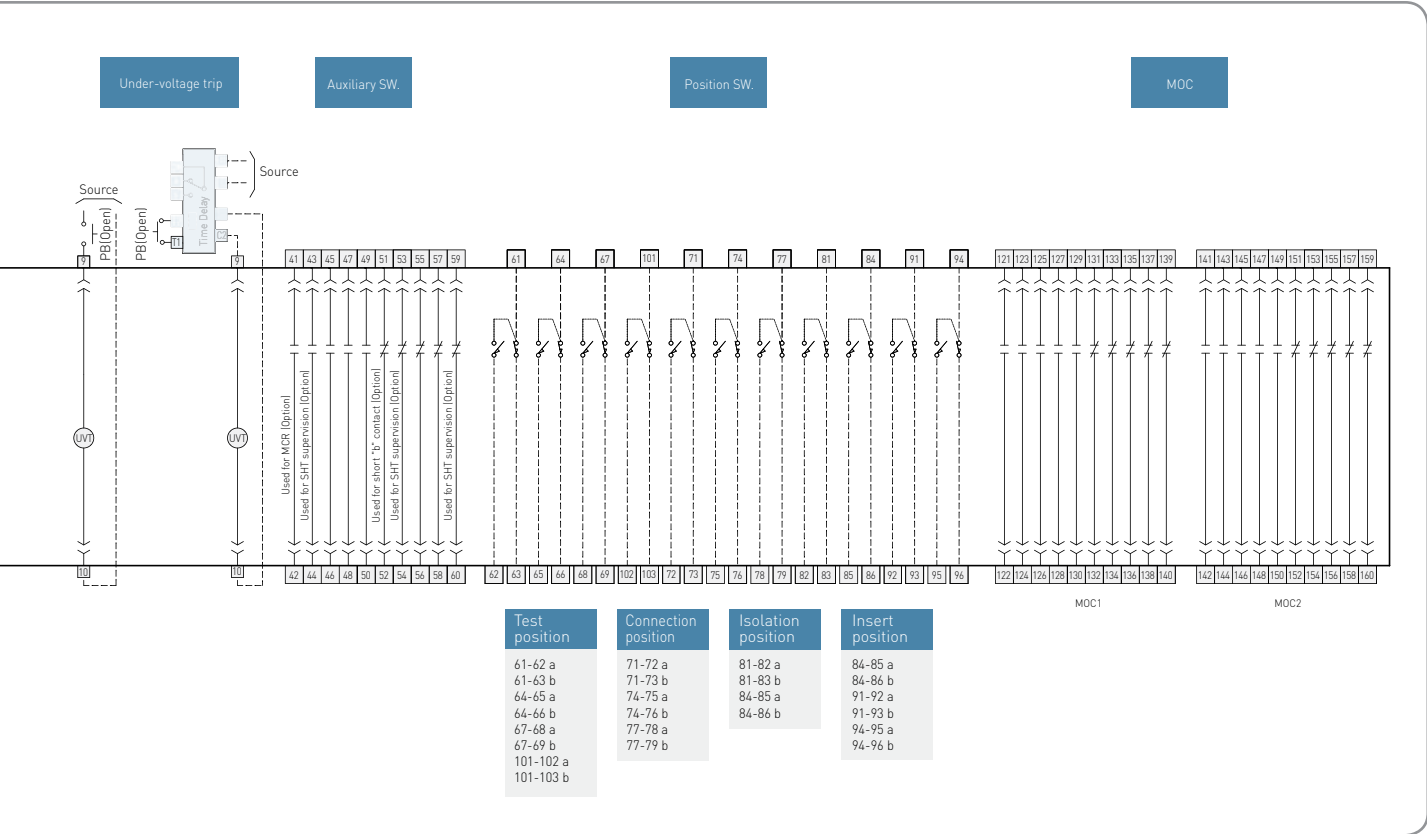

Auto control jack lay-out

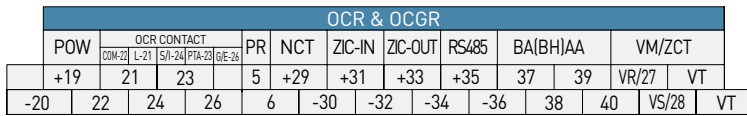
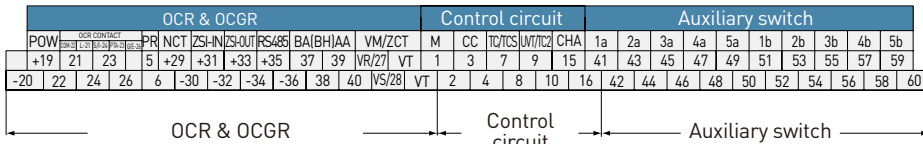

- OCR & OCGR -

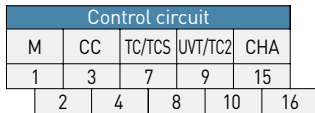

- Control circuit -

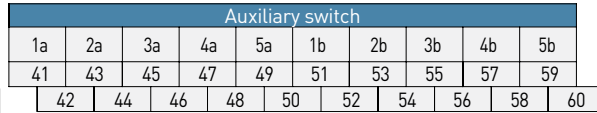

- Auxiliary switch -

Over-current protective device (standard type)

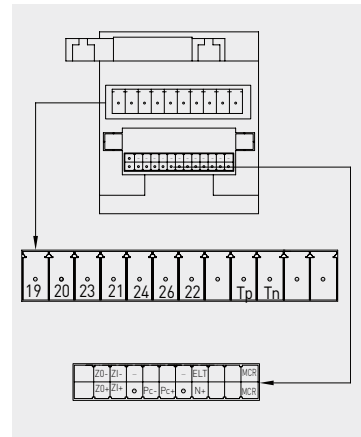

Manual control jack lay-out

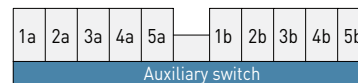
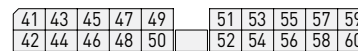
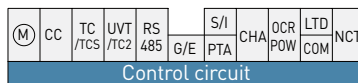
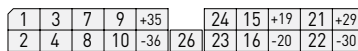
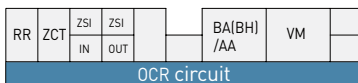

Dimensions

| UAN06 - 20/UAS06 - 16 fixed type (A frame) |

(unit: mm)

Front

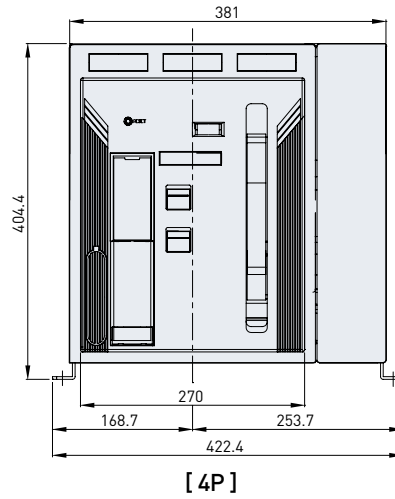
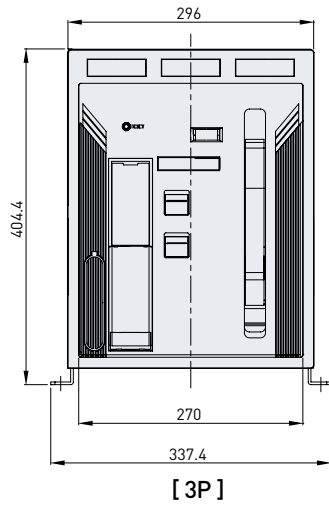

Vertical terminal connection

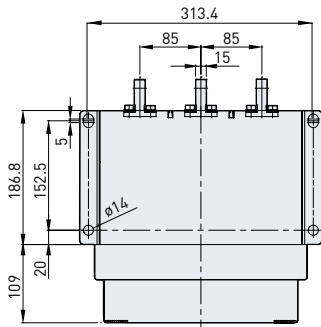

[630 - 1,600A]

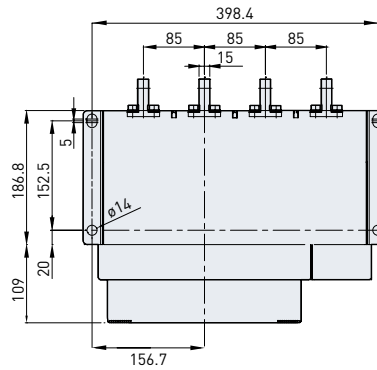

[2,000A]

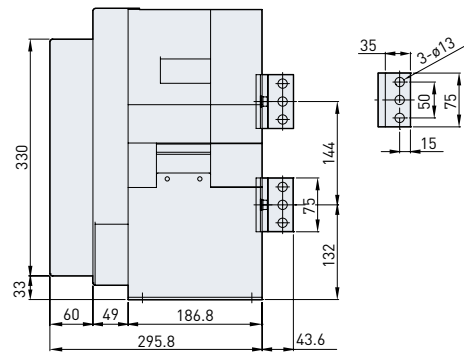
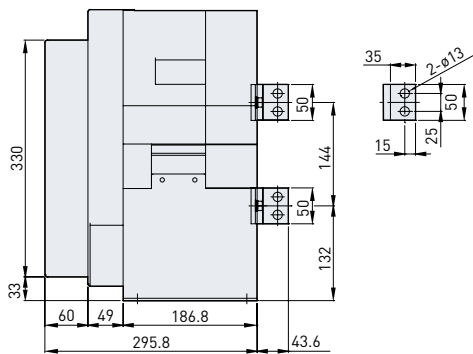

※ A frame 2,000A of UAN fixed type is applicable horizontal terminal only.

(unit: mm)

Horizontal terminal connection

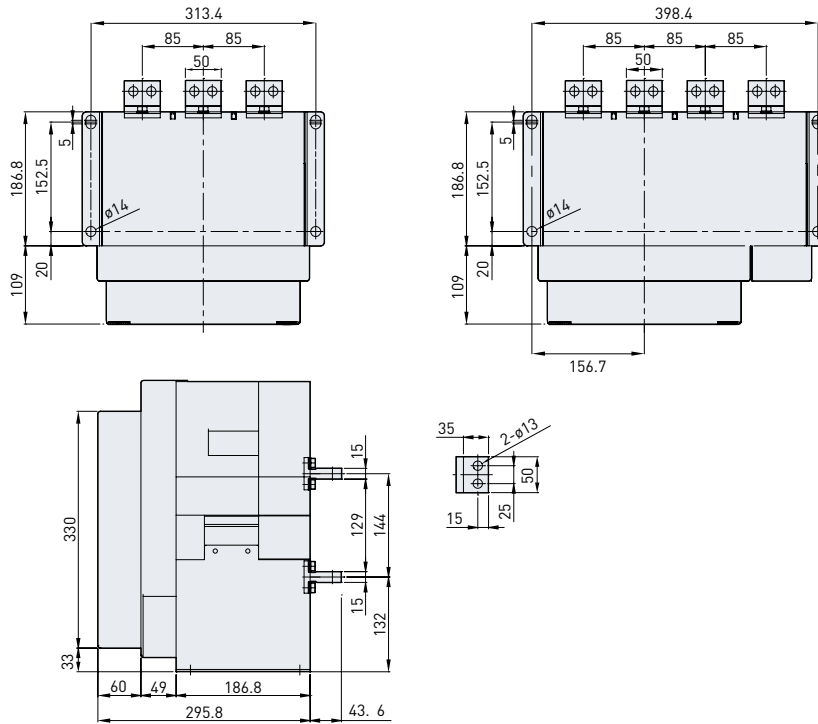

Front terminal connection

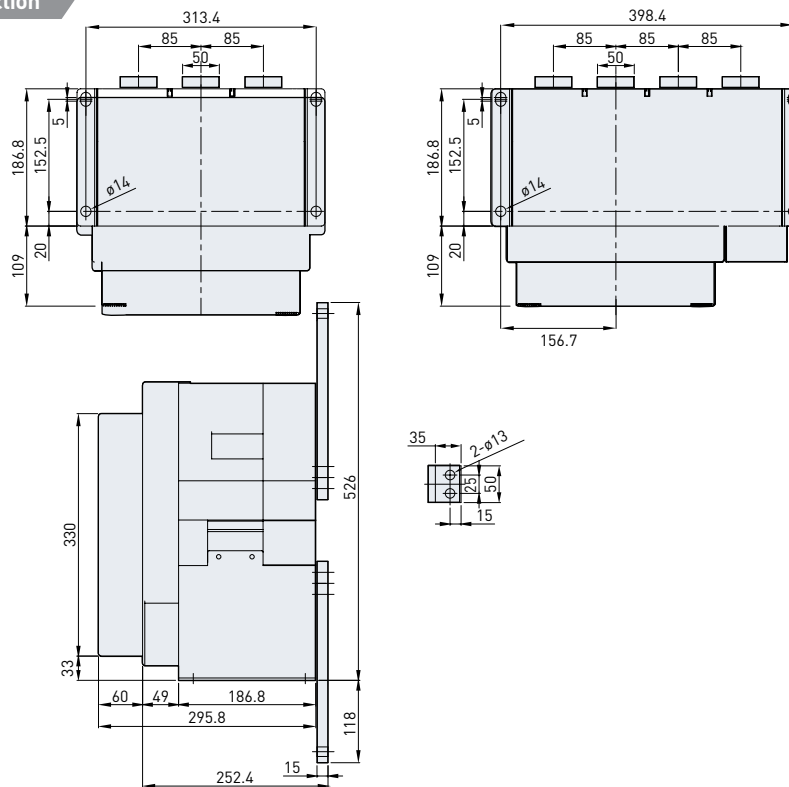

Dimensions

| UAN06 - 20/UAS06 - 16 draw-out type (A frame) |

(unit: mm)

Front

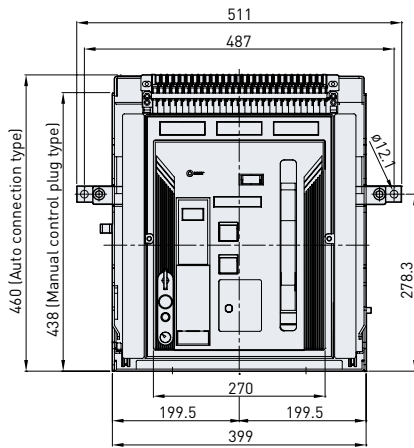

[3P]

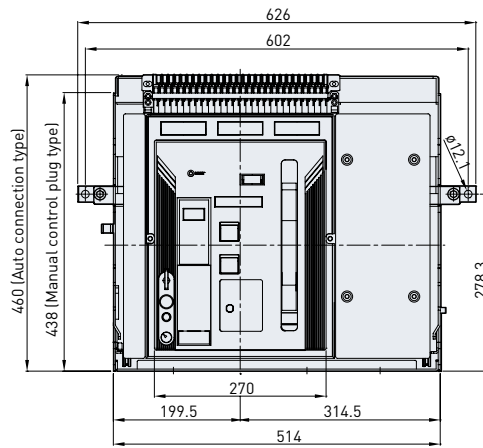

[4P]

Vertical terminal connection

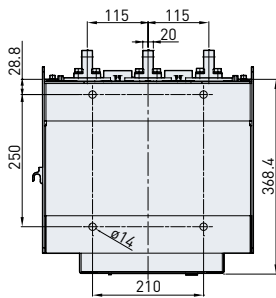

[UAS/UAN 630 - 2,500A]

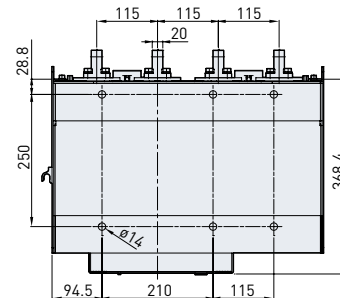

[UAN 3,200A]

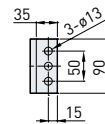
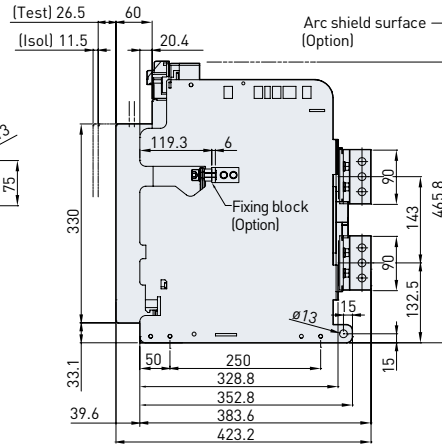
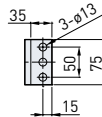
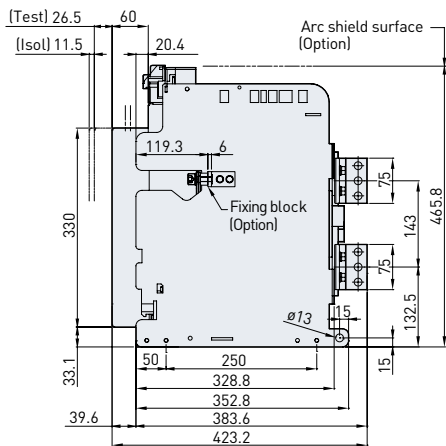

※ A frame 2,000A of UAN fixed type is applicable horizontal terminal only.

(unit: mm)

Horizontal terminal connection

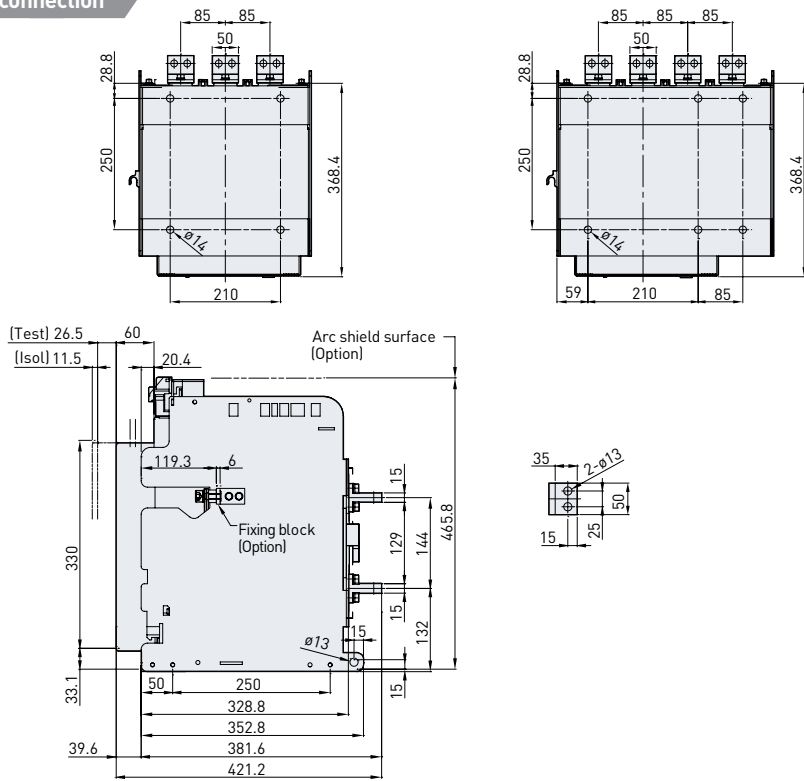

Front terminal connection

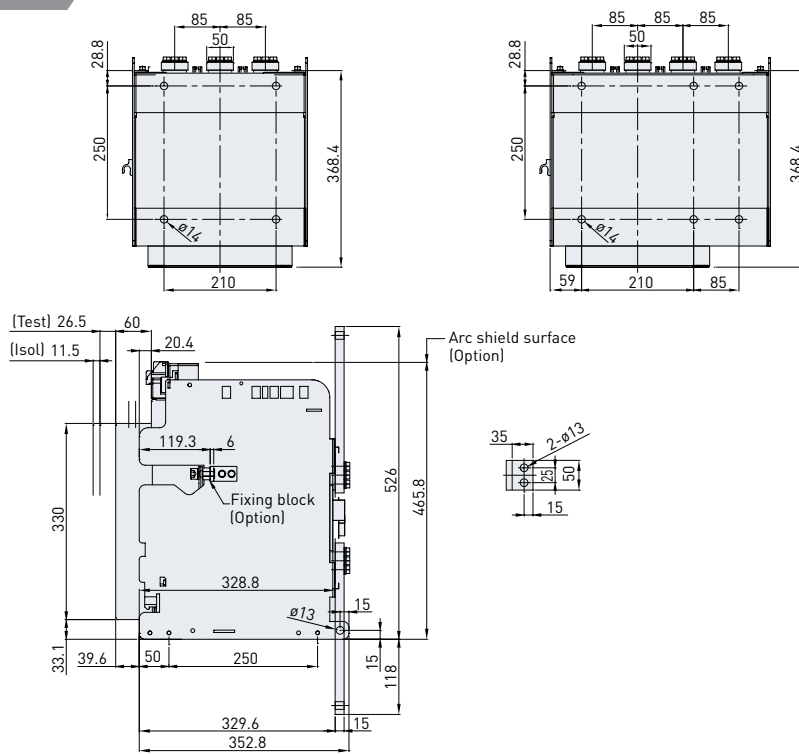

Dimensions

| UAN06 - 32/UAS20 - 32 fixed type (B frame) |

(unit: mm)

Front

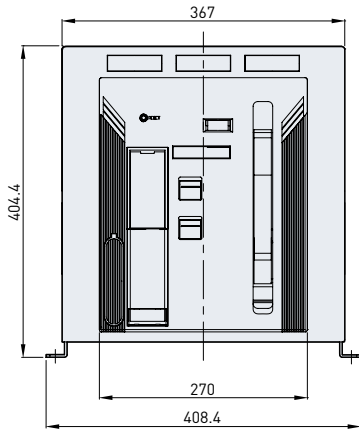

[3P]

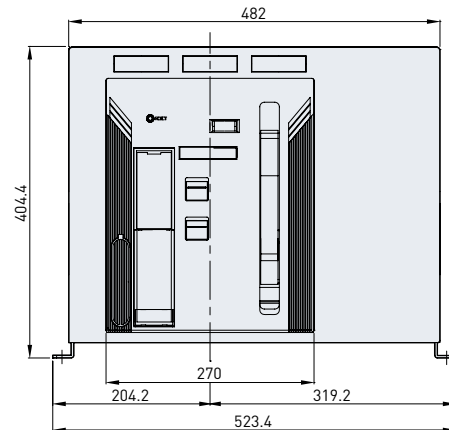

[4P]

Vertical terminal connection

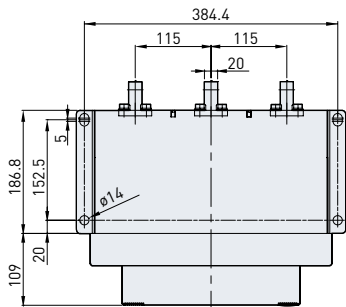

[630-2,500A]

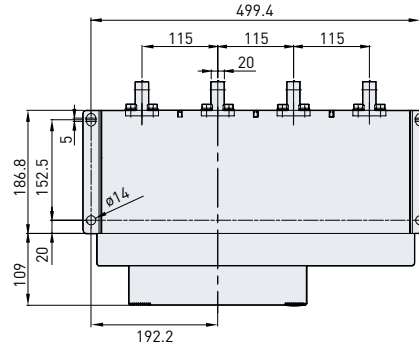

[3,200A]

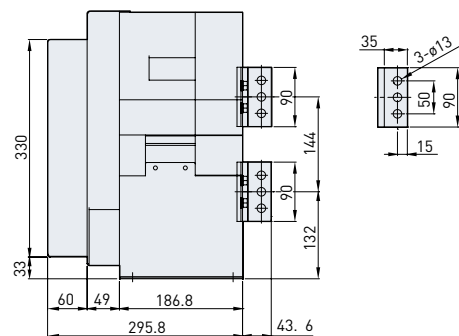
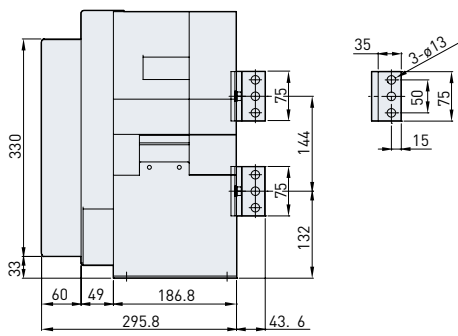

(unit: mm)

Horizontal terminal connection

Name	Detail "A"
UAN20(06)-25	75
UAN32	90

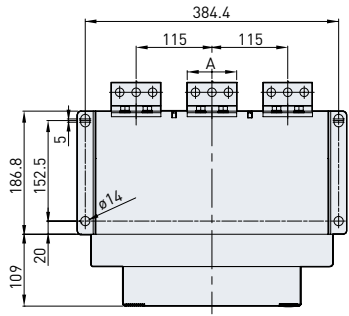

[2,000 - 2,500A]

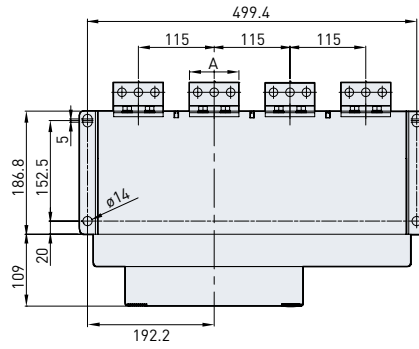

[3,200A]

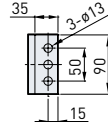
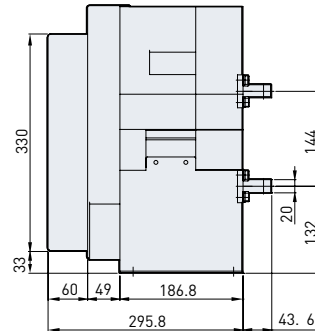
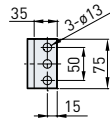
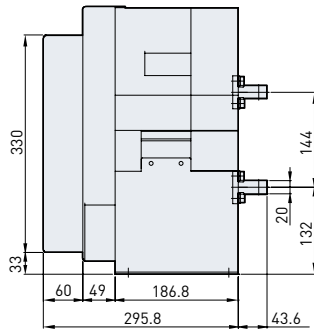

Front terminal connection

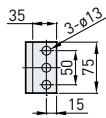
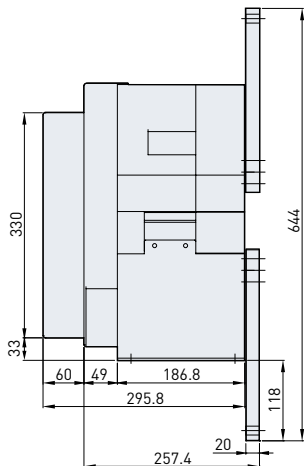
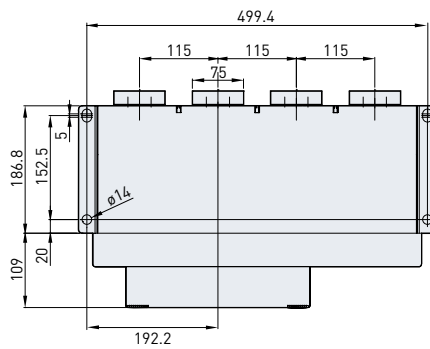
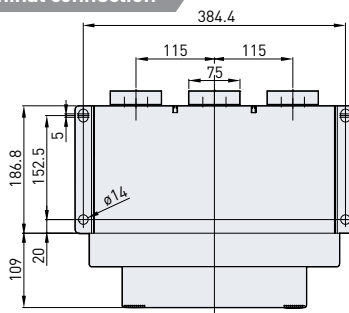

Dimensions

| UAN06 - 32/UAS20 - 32 draw-out type (B frame) |

(unit: mm)

Front

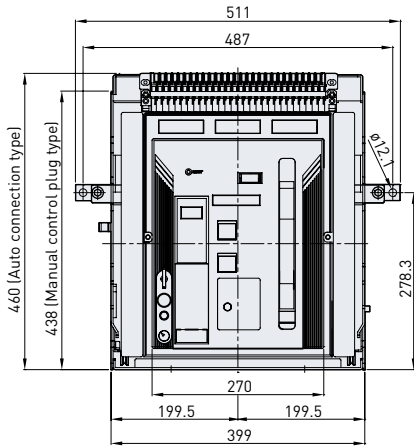

[3P]

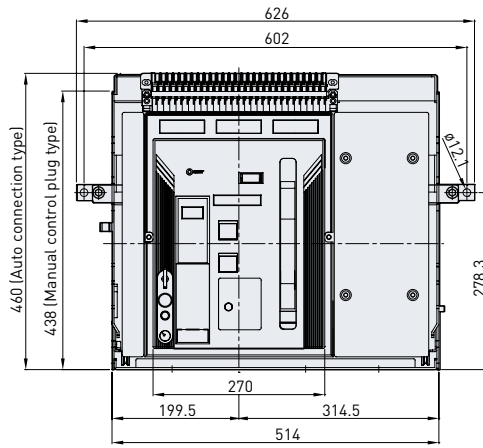

[4P]

Vertical terminal connection

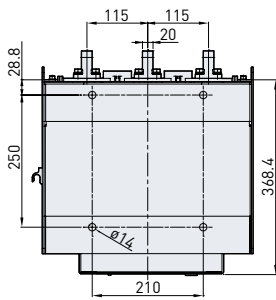

[630 - 2,500A]

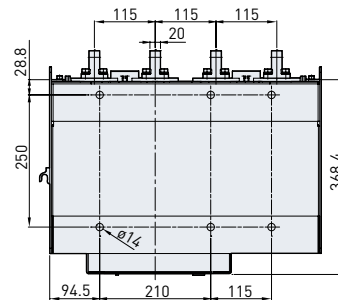

[3,200A]

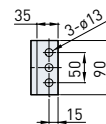
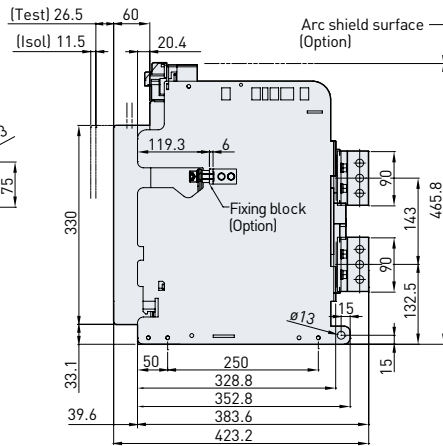
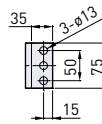
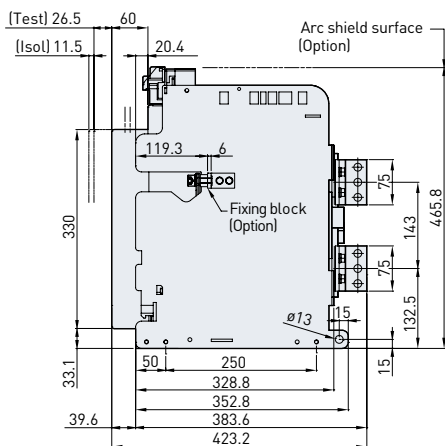

(unit: mm)

Horizontal terminal connection

Name	Detail "A"
UAN20(06)-25	75
UAN32	90

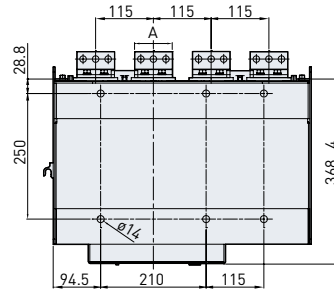
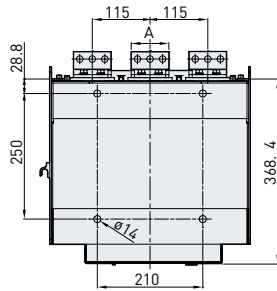

[2,000 - 2,500A]

[3,200A]

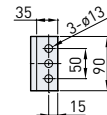
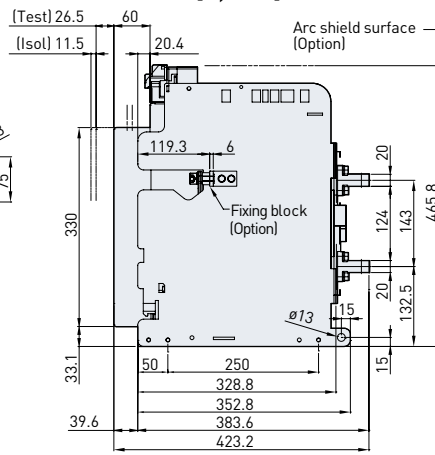
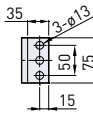
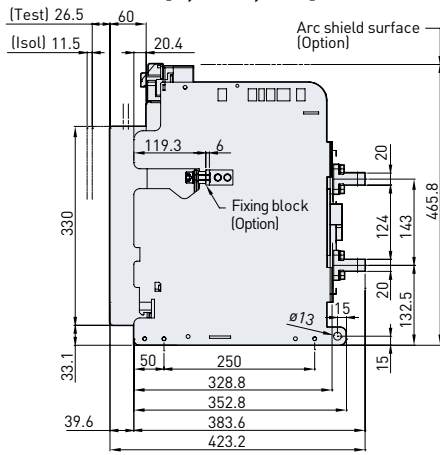

Front terminal connection

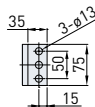
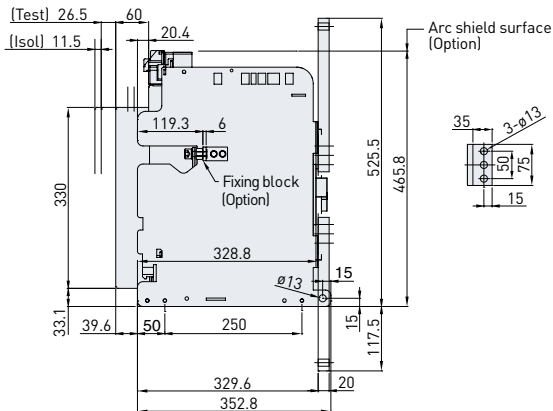
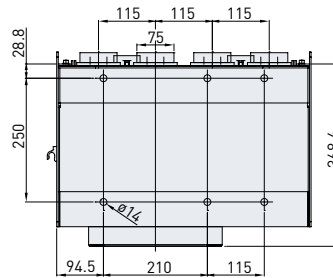
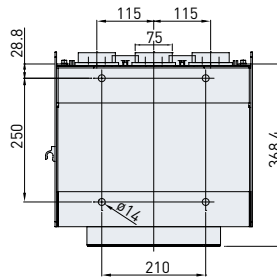

Dimensions

| UAN40 fixed type (B frame) |

(unit: mm)

Front

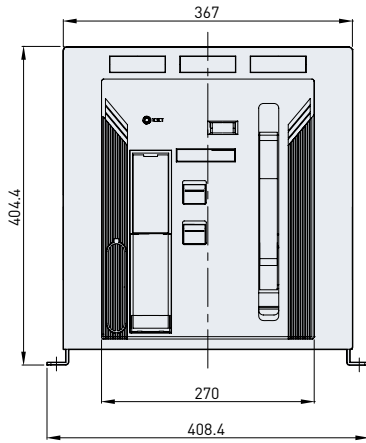

[3P]

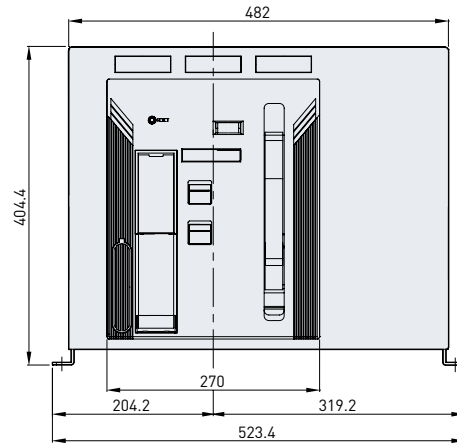

[4P]

Vertical terminal connection

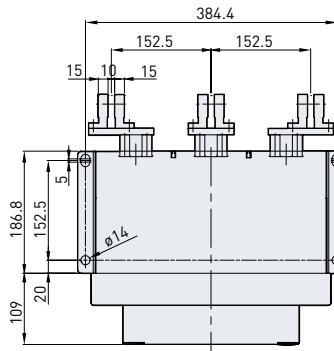

[4,000A]

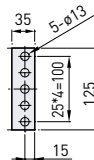
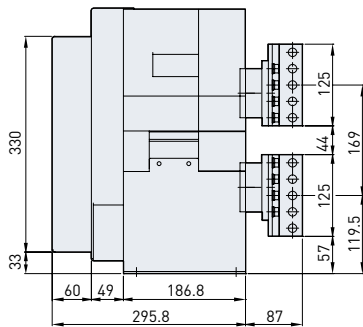
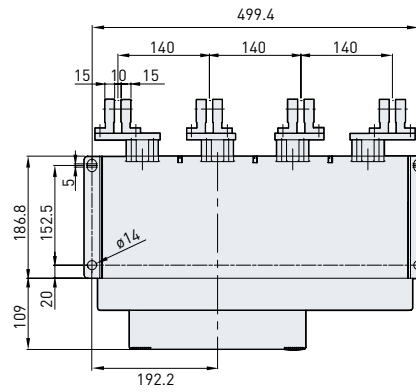

(unit: mm)

Horizontal terminal connection

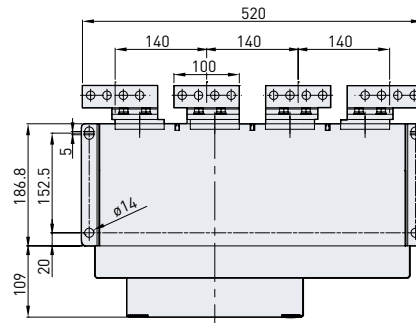
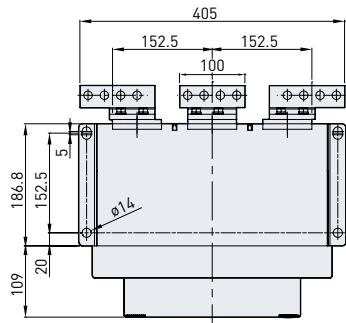

[4,000A]

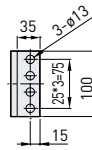
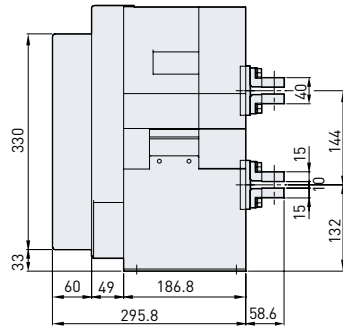

Dimensions

| UAN40 draw-out type (B frame) |

(unit: mm)

Front

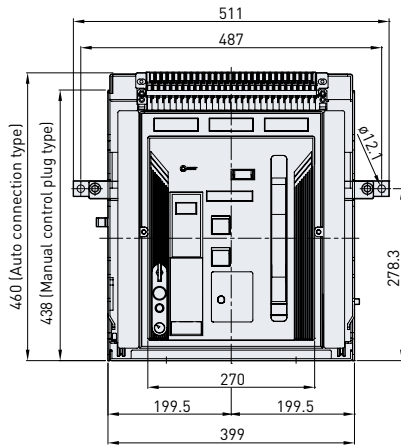

[3P]

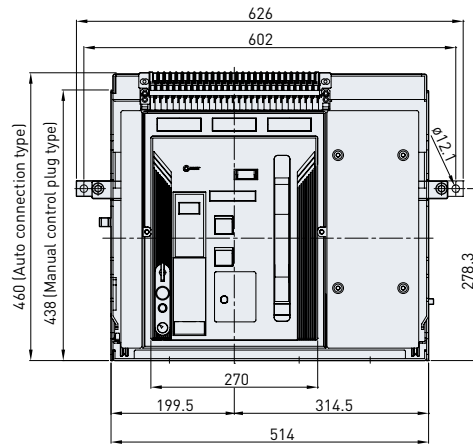

[4P]

Vertical terminal connection

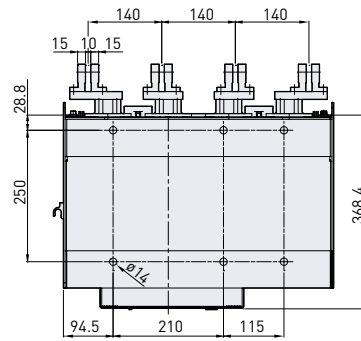
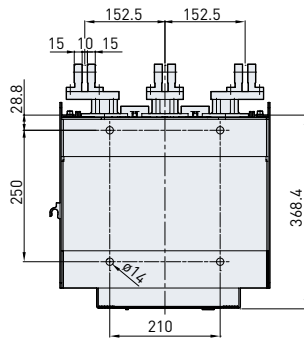

[4,000A]

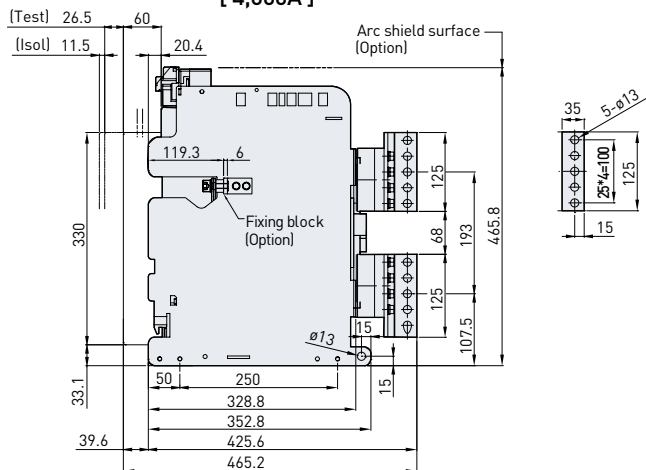

(unit: mm)

Horizontal terminal connection

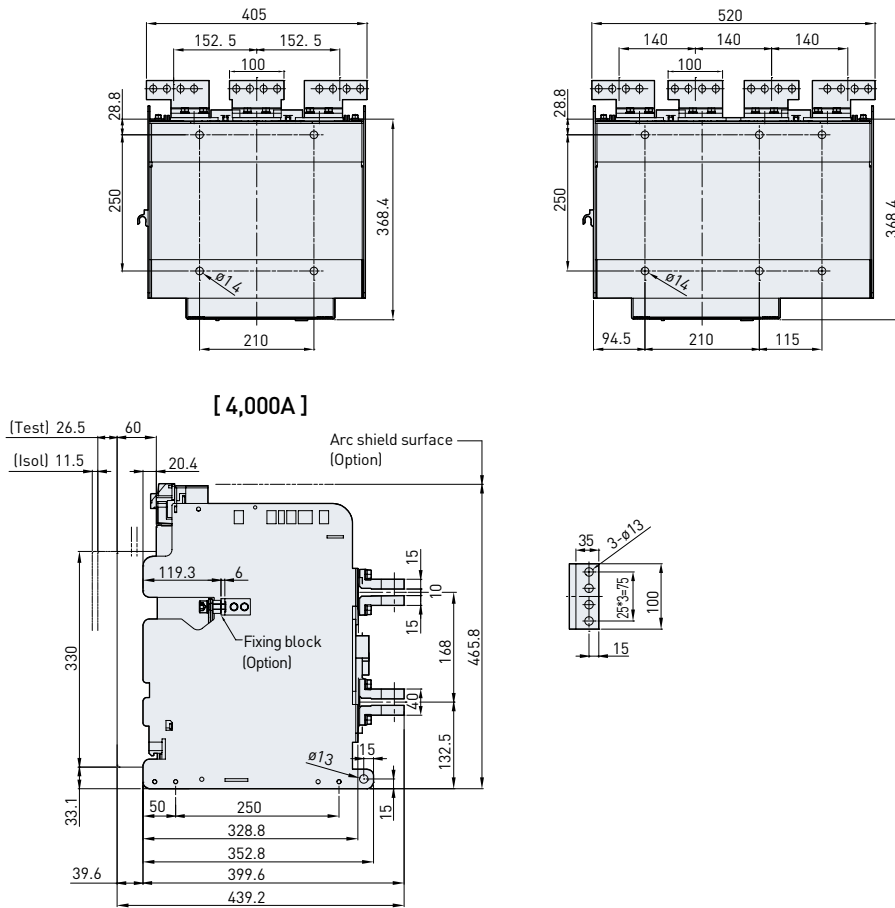

Dimensions

| UAN32 - 50 fixed type (C frame) |

(unit: mm)

Front

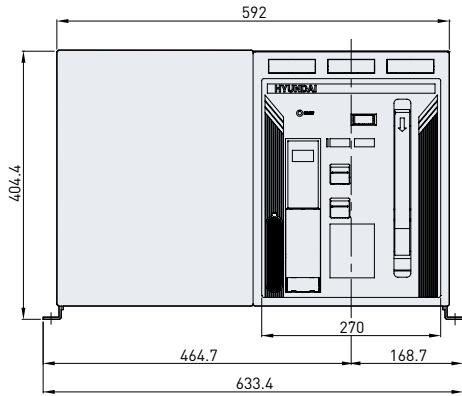

[3P]

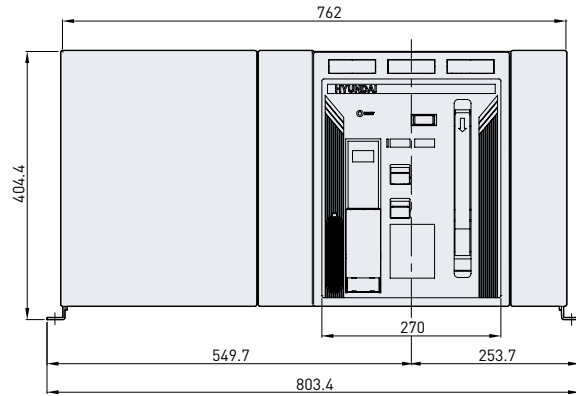

[4P]

Vertical terminal connection

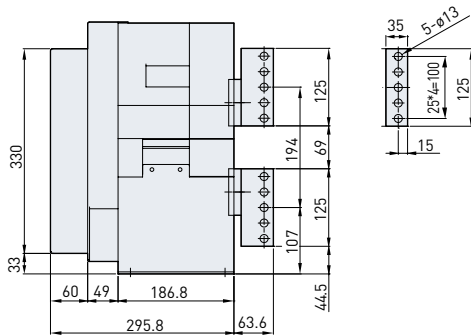
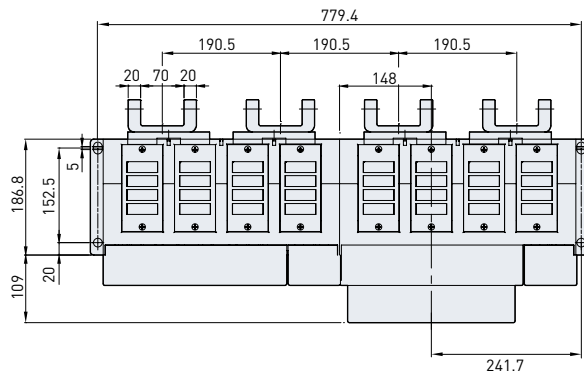
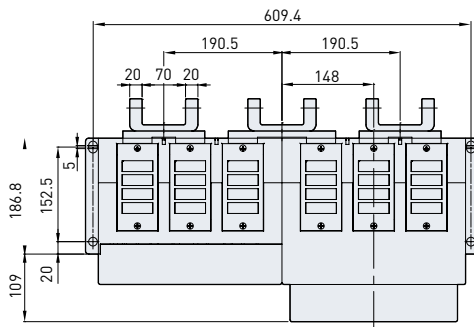

(unit: mm)

Horizontal terminal connection

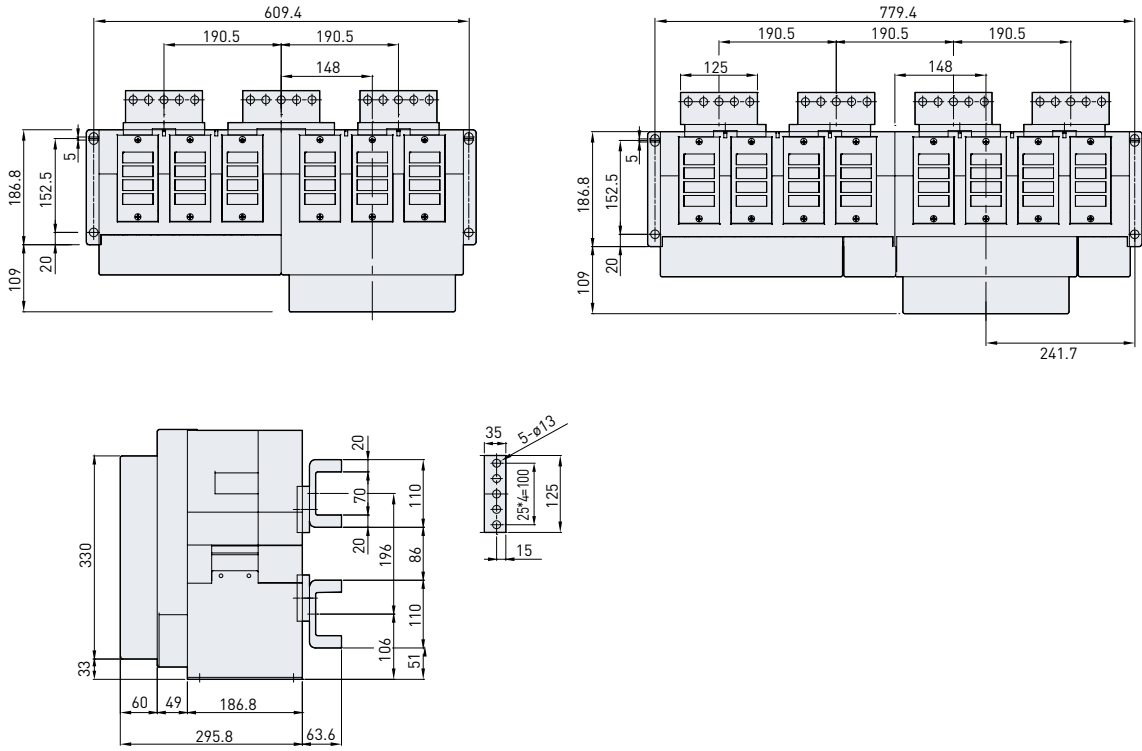

(unit: mm)

Horizontal terminal connection

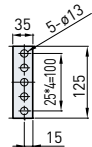
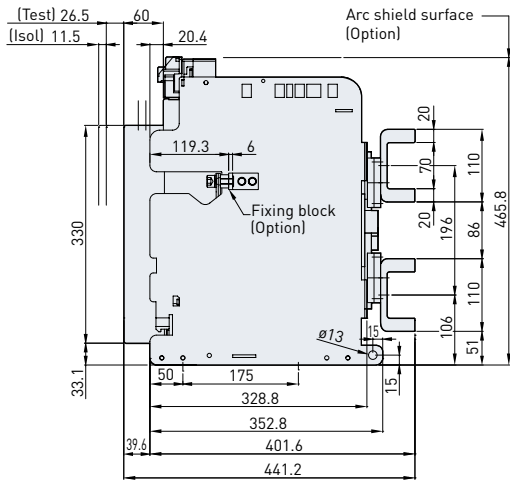
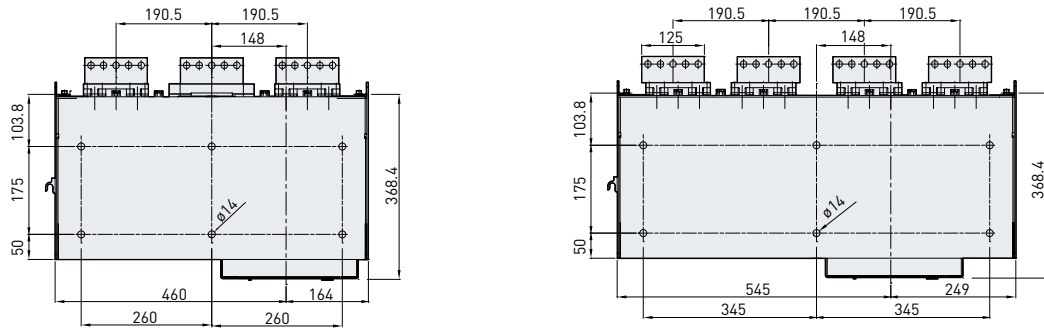

Dimensions

| Draw-out type |

(unit: mm)

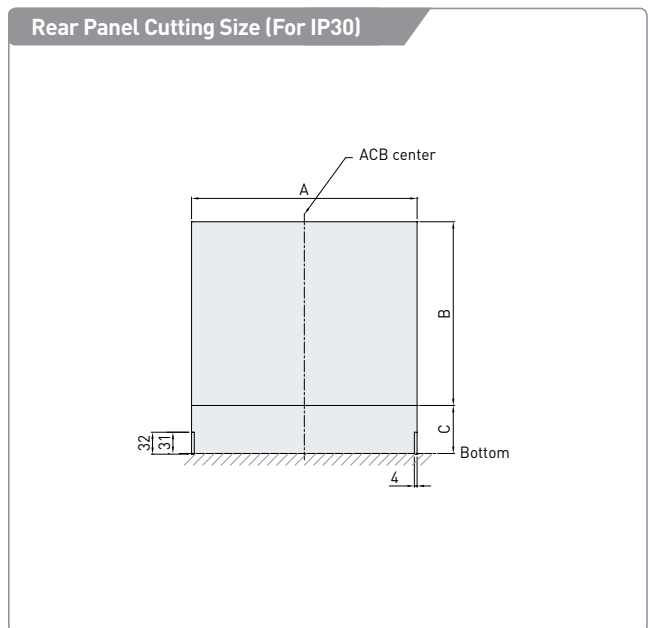
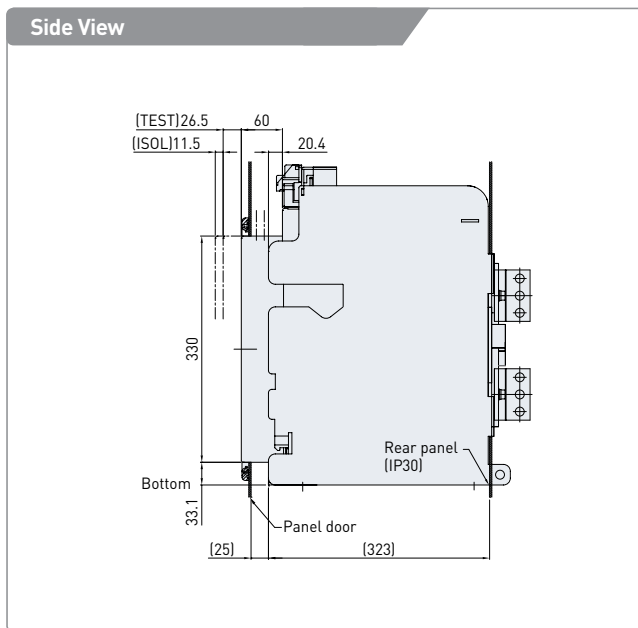
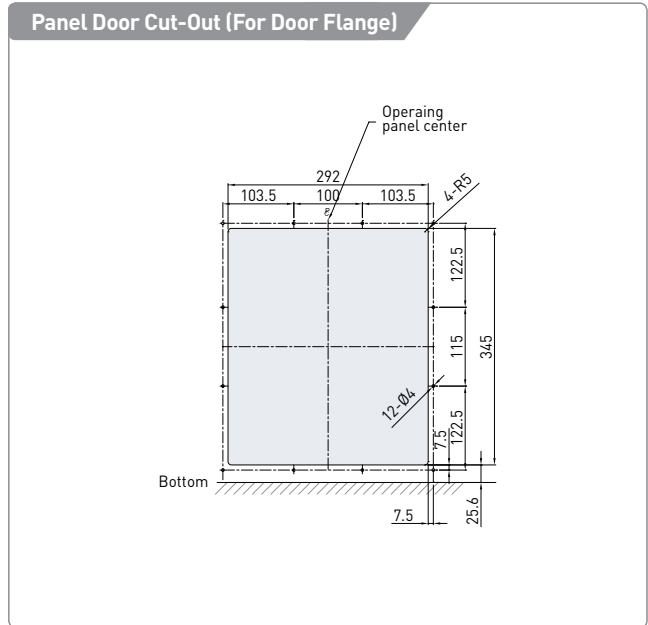
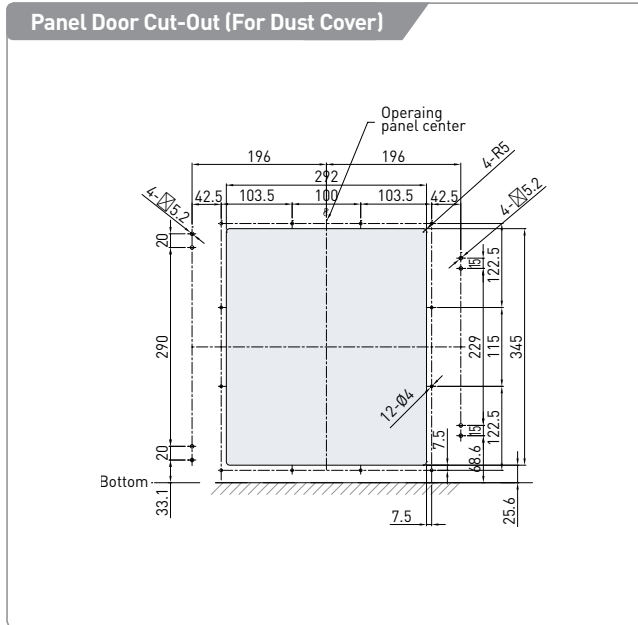

■ Real panel cutting size

Model	A	B	C
UAN 06A3 - 20A3, UAS 06A3 - 16A3	329	268	70
UAN 06A4 - 20A4, UAS 06A4 - 16A4	414	268	70
UAN 06B3 - 40B3, UAS 20B3 - 32B3	400	298	55
UAN 06B4 - 40B4, UAS 20B4 - 32B4	515	298	55
UAN 32C3 - 50C3	625	338	35
UAN 32C4 - 50C4	795	338	35

| Fixed type |

(unit: mm)

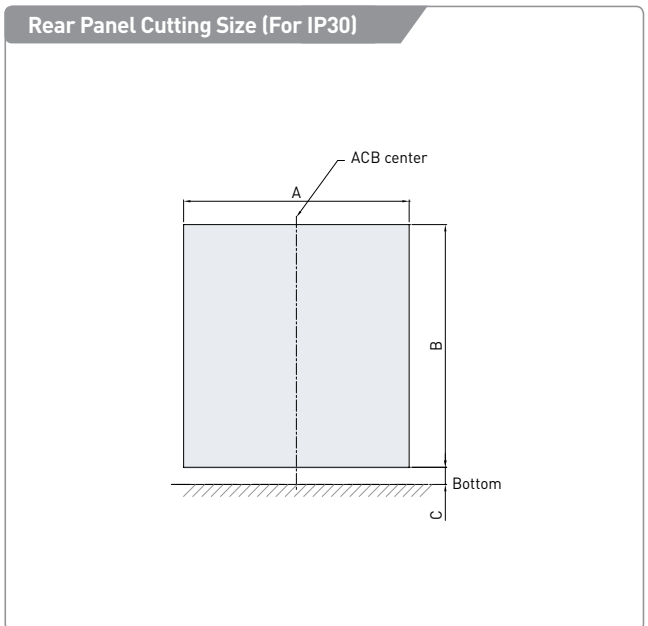
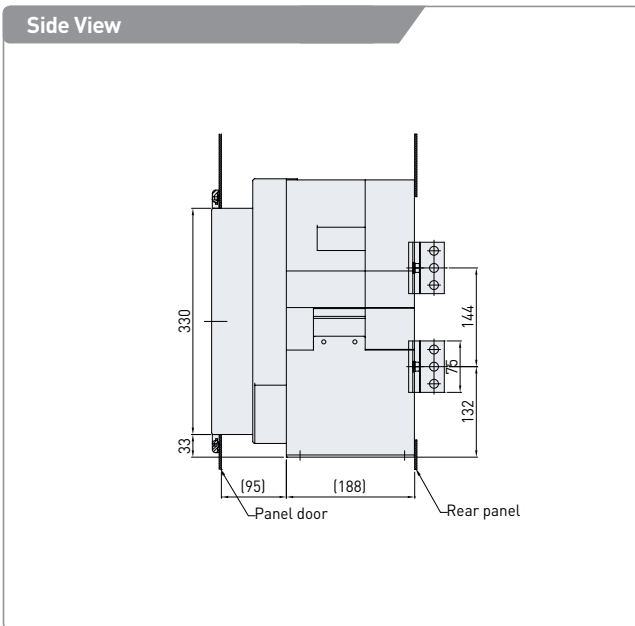
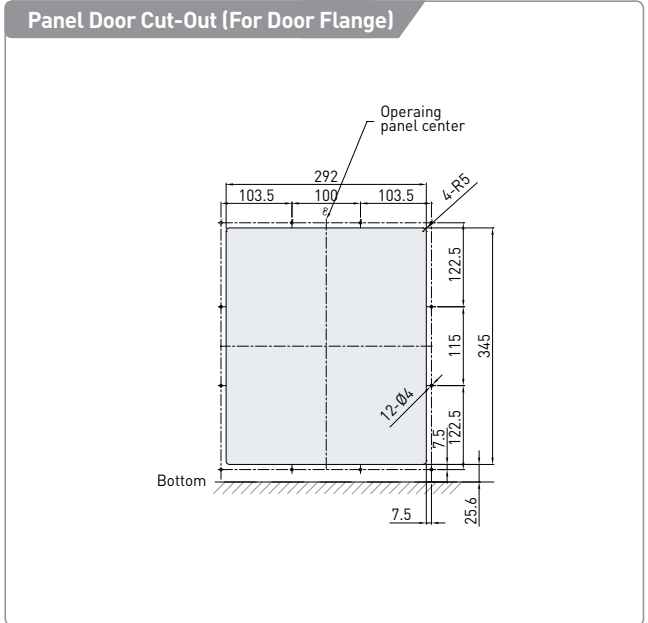
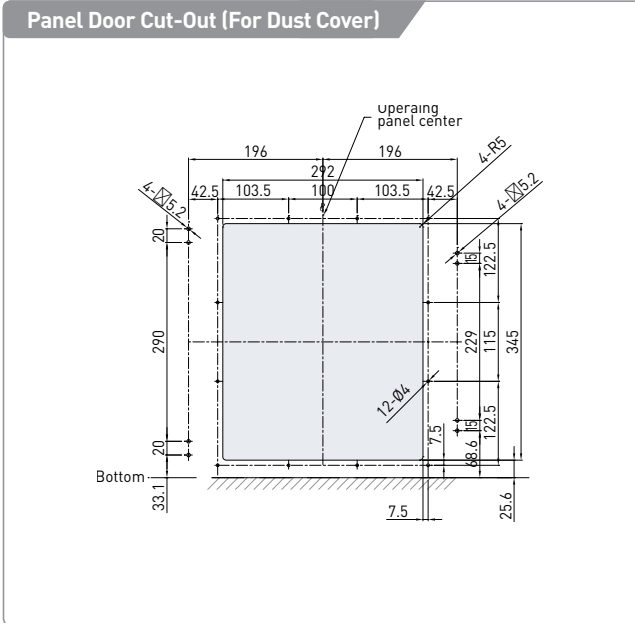

■ Real panel cutting size

Model	A	B	C
UAN 06A3 - 20A3, UAS 06A3 - 16A3	283	355	25
UAN 06A4 - 20A4, UAS 06A4 - 16A4	368	355	25
UAN 06B3 - 40B3, UAS 20B3 - 32B3	354	355	25
UAN 06B4 - 40B4, UAS 20B4 - 32B4	469	355	25
UAN 32C3 - 50C3	579	355	25
UAN 32C4 - 50C4	749	355	25

Ordering Codes

UAN type I

■ ACB body part

UAN	12	A	3	J	M2		
Type	Rated current		Pole	Terminal connection		Motor	
UAN	06 630A	A 2,000AF, 630 - 2,000A 3P: RST, 4P: RSTN	3 3 Pole	Drawout type/Only ACB control terminal connection		M0	Manual type
	08 800A		4 4 Pole	A Auto connection		M1	AC/DC110V
	10 1,000A	W 2,000AF, 630 - 2,000A 4P: NRST		J Manual connection		M2	AC/DC220V
	12 1,250A		Fixed type/ Terminal busbar arrangement		M3	AC380V ⁴⁾	
	16 1,600A	B 4,000AF, 630 - 4,000A 3P: RST, 4P: RSTN		H Horizontal type	M4	AC440V ⁴⁾	
	20 2,000A ¹⁾		X 4,000AF, 630 - 4,000A 4P: NRST		V Vertical type	M7	DC24V
	06 630A	C 5,000AF, 3,200 - 5,000A 3P: RST, 4P: RSTN			T Upper side: Horizontal Lower side: Vertical	M8	DC48V
	08 800A		Y 5,000AF, 3,200 - 5,000A 4P: NRST		L Upper side: Vertical Lower side: Horizontal	M9	DC125V
	10 1,000A	D 6,300AF, 4,000 - 6,300A 3P: RST, 4P: RSTN			P ³⁾ Front type or others		
	12 1,250A		Z 6,300AF, 4,000 - 6,300A 4P: NRST		Draw-out type(ACB+cradle) control terminal connection+terminal busbar arrangement		
	16 1,600A				B Auto connection + Horizontal type		
	20 2,000A			C Auto connection + Vertical type			
	25 2,500A			D Auto connection + Upper side: Horizontal Lower side: Vertical			
	32 3,200A			E Auto connection + Upper side: Vertical Lower side: Horizontal			
	40 4,000A			G ³⁾ Auto connection + Front type or others			
	32 3,200A			K Manual connection + Horizontal type			
	40 4,000A			M Manual connection + Vertical type			
	50 5,000A			N Manual connection + Upper side: Horizontal Lower side: Vertical			
	40 4,000A ²⁾			Q Manual connection + Upper side: Vertical Lower side: Horizontal			
	50 5,000A ²⁾			R ⁵⁾ Manual connection + Front type or others			
	63 6,300A ²⁾						

※ 1) Frame A, 2,000A is available only for the vertical terminal busbar arrangement.

2) Frame D, 4,000 - 6,300A is applicable since 2015-1st half.

3) P type of fixed terminal busbar arrangement should be ordered and attached personally. (refer to the additional components). Applicable frames are A06-16, B06-32.

4) Charging motor AC380V, AC440V is applicable since 2015.

5) CT application

- Frame A/W: 200 - 2,000A

- Frame B/X: 400 - 4,000A

- Frame C/Y: 3,200 - 5,000A

- Frame D/Z: 4,000 - 6,300A

C2		S2		61		K		AB			
Closing coil		Trip coil		Overcurrent trip		CT		Only body accessories		ACB+Cradle accessories (only for cradle arrangement)	
C0	N/A	S0	N/A	General feeder		0	N/A	Instaneous type (Only UVT coil)		Delay type (UVT coil+Controller)	
C1	AC/DC110V	S1	AC/DC110V	00	N/A	0	200A	U1	AC/DC110V	V1	AC/DC110V
C2	AC/DC220V	S2	AC/DC220V	50Hz		V	320A	U2	AC/DC220V	V2	AC/DC220V
C3	AC380V	S3	AC380V	50	UPR-LN	E	400A	U3	AC380V	V3	AC380V
C4	AC440V	S4	AC440V	51	UPR-LA	T	630A	U4	AC440V	V4	AC440V
C7	DC24V	S7	DC24V	52	UPR-LAG	H	800A	U7	DC24V	V9	DC125V
C8	DC48V	S8	DC48V	53	UPR-LAZ	J	1,000A	U8	DC48V	Position switch	
C9	DC125V	S9	DC125V	54	UPR-LP	K	1,250A	U9	DC125V		
		Trip supervision coil		60Hz		L	1,600A	Secondary trip coil		AQ	Test 1C, Connected 1C
		T1	AC/DC110V	60	UPR-LN	M	2,000A	S1	AC/DC110V	AR	Connected 2C
		T2	AC/DC220V	61	UPR-LA	N	2,500A	S2	AC/DC220V	AS	Test 2C
		T3	AC380V	62	UPR-LAG	P	3,200A	S3	AC380V	AT	Isolated 1C, Inserted 1C
		T4	AC440V	63	UPR-LAZ	Q	4,000A	S4	AC440V	AU	Inserted 2C
		T7	DC24V	64	UPR-LP	S	5,000A	S7	DC24V	AV	Isolated 2C
		T8	DC48V	66	UPR-LH	X	6,300A	S8	DC48V	P4	Test 2C, Connected 2C
		T9	DC125V	Generator				S9	DC125V	PT	Test 4C
				50Hz						PS	Isolated 1C, Test 1C, Connected 2C
				57	UPR-SN					PQ	Inserted 1C, Isolated 1C, Test 1C, Connected 1C
				58	UPR-SA					P8	Inserted 2C, Isolated 2C, Test 2C, Connected 2C
				59	UPR-SP					PR	Inserted 1C, Isolated 1C, Test 3C, Connected 3C
				60Hz							
				67	UPR-SN			AM	ON/OFF button cover	BC	Auto connection control terminal cover
				68	UPR-SA			AA	Additional 1a1b auxiliary switch	MC	Mechanical operated cell switch (MOC) 10a10b
				69	UPR-SP			AB	Key lock device (prevent ON)	AK	Short "b" contact for auto connection terminal
								B8	OCR MCR function	AE	Safe shutter lock
								BR	OCR manual reset function	AX	Arc shield
								BA	OCR manual reset & alarm switch reset device	AF	Fixing block
								BH	OCR manual reset + high capacity alarm switch 1a	AW	Miss-insertion preventer
								B0	Internal part for mechanical interlock	TM	Temperature sensor bracket
								B6	Spring charge switch	ATS production	
								AG	Door flange	BAB7	Auto transfer switch
								MR	Marine switchgear	MR	Marine switchgear

• U-series accessories are only applicable for instantaneous type and only UVT coil can be installed. When you want to use delay type, you can purchase delay type of controller (UANS-) additionally and install externally.

• V-series accessories are only applicable for the delay type and UVT coil is installed on main body, delay type controller is installed at the side of cradle. If you have any problem with size, you can purchase UANS V-series which can be installed additionally.

• B0: Internal part for mechanical interlock should be purchased additionally. If you mark B0, only internally interlocking components are transported with assembly (refer to additional components).

• S-secondary trip coils are not compatible with UVT coil at the same time.

• In case of TSC, AUX S/W becomes 4a4b. And using MCR function of B8 OCR, AUX S/W becomes 4a5b. When using both TSC and MCR function, AUX S/W becomes 3a4b.

• Purchasing with solely main body code (A/J/ Fixed type), it cannot be arranged with cradle accessories. Cradle accessory arrangement is possible when purchased with cradle arrangement. You should purchase additionally when you want main body (UANS-) solely (refer to additional components).

• Position switch cannot be overlapped and can be attached only on the right side of cradle. Inquire us personally if you need another arrangement.

• Internal part for mechanical interlock (B0), mechanical operated cell switch (MOC), fixing block (AF) are not compatible one another.

• BC: Auto connection control terminal cover is only available for the auto connection.

• AK: "Short "b"" is only available for auto connection and attached on 51, 52. It can be attached by the number of "B" points, so additionally purchase if you want to attach more.

• UVT and TC2 cannot be attached both.

• AG: Additionally attached originally, but inserted on front cover when shipped.

• MR: AE, AG, AF, AM are attached as a standard option, so those accessories are not marked additionally.

• AG: AA and BA(BH) cannot be attached at the same time.

• UVT and TC2 cannot be attached at the same time.

Ordering Codes

I DUN type I

■ Cradle part for draw-out type ACB

DUN		12		A		3		A		H		AE	
Type		Rated current		Frame size & pole arrangement		Pole		Control terminal connection		Terminal busbar arrangement		Accessories	
DUN	16	DUN06 - 16A(W)	A	2,000AF, 630 - 2,000A	3	3 Pole	A	Auto connection	H	Horizontal type	AE	Safe shutter lock	
	20	DUN20A(W) ¹⁾		2,000AF, 630 - 2,000A	4	4 Pole			J	Manual connection			V
	25	DUN06 - 25B(X)	B	4,000AF, 630 - 4,000A					T	Upper side: Horizontal Lower side: Vertical			
	32	DUN32B(X)		4,000AF, 630 - 4,000A					L	Upper side: Vertical Lower side: Horizontal			
	40	DUN40B(X)		4P: RSTN/NRST					P ³⁾	Front type or others			
	50	DUN32 - 50C(Y)	C	5,000AF, 3200 - 5,000A									
				5,000AF, 3200 - 5,000A									
	50 ²⁾	DUN40 - 50D(Z)	D	6,300AF, 4,000-6,300A									
	63 ²⁾	DUN63D(Z)		3P: RST									
				4P: RSTN/NRST									

* AE: Safety shutter lock is supplied with safety shutter.

※ 1) Frame A, 2,000A is available only for the vertical terminal busbar arrangement.

2) Frame D, 4,000 - 6,300A is applicable since 2015.

3) P type of fixed terminal busbar arrangement should be ordered and attached personally (refer to the additional components). And applicable frames are A06 - 16, B06 - 32

Ordering Codes

I UAS type I

■ ACB body part

UAS	12	A	3	J	M2		
Type	Rated current		Pole	Terminal connection		Motor	
UAS	06	630A	3	Draw-out type/only ACB Control terminal connection		M0	Manual type
	08	800A	4	A	Auto connection	M1	AC/DC110V
	10	1,000A		J	Manual connection	M2	AC/DC220V
	12	1,250A		Fixed type/ Terminal busbar arrangement		M3	AC380V ²⁾
	16	1,600A				H	Horizontal type
	20	2,000A		V	Vertical type	M7	DC24V
	25	2,500A		T	Upper side: Horizontal Lower side: Vertical	M8	DC48V
	32	3,200A		L	Upper side: Vertical Lower side: Horizontal type	M9	DC125V
				P ¹⁾	Front type or others		
				Draw-out type (ACB+cradle) Control terminal connection+Terminal busbar arrangement			
				B	Auto connection + Horizontal type		
				C	Auto connection + Vertical type		
				D	Auto connection + Upper side : Horizontal Lower side: Vertical		
				E	Auto connection + Upper side: Vertical Lower side: Horizontal		
				G	Auto connection + Front type or others		
				K	Manual connection + Horizontal type		
				M	Manual connection + Vertical type		
				N	Manual connection + Upper side : horizontal Lower side: Vertical		
				Q	Manual connection + Upper side : Vertical Lower side: Horizontal		
				R	Manual connection + Front type or others		

※ 1) P type of fixed terminal busbar arrangement should be ordered and attached personally (refer to the additional components).

2) Charging motor AC380V, AC440V is applicable since 2015-1st half.

3) CT application

O(200A), V(320A) is available for only A frame.

C2		S2		61		K		AB			
Closing coil		Trip coil		Overcurrent trip		CT		Only body accessories		ACB+cradle accessories (only for cradle arrangement)	
C0	N/A	S0	N/A	General feeder		0	N/A	Instantaneous type (UVT coil)		Double trip (UVT Coil + UVT Controller)	
C1	AC/DC110V	S1	AC/DC110V	00	N/A	0	200A ¹⁾	U1	AC/DC110V	V1	AC/DC110V
C2	AC/DC220V	S2	AC/DC220V	50Hz		V	320A ¹⁾	U2	AC/DC220V	V2	AC/DC220V
C3	AC380V	S3	AC380V	50	UPR-LN	E	400A	U3	AC380V	V3	AC380V
C4	AC440V	S4	AC440V	51	UPR-LA	T	630A	U4	AC440V	V4	AC440V
C7	DC24V	S7	DC24V	52	UPR-LAG	H	800A	U7	DC24V	V9	DC125V
C8	DC48V	S8	DC48V	53	UPR-LAZ	J	1,000A	U8	DC48V	Position switch	
C9	DC125V	S9	DC125V	54	UPR-LP	K	1,250A	U9	DC125V		
				60Hz		L	1,600A	Secondary trip coil		AQ	Test 1C, connected 1C
				60	UPR-LN	M	2,000A	S1	AC/DC110V	AR	Connected 2C
				61	UPR-LA	N	2,500A	S2	AC/DC220V	AS	Test 2C
				62	UPR-LAG	P	3,200A	S3	AC380V	AT	Isolated 1C, inserted 1C
				63	UPR-LAZ			S4	AC440V	AU	Inserted 2C
				64	UPR-LP			S7	DC24V	AV	Isolated 2C
								S8	DC48V	P4	Test 2C, connected 2C
								S9	DC125V	PT	Test 4C
										PS	Isolated 1C, test 1C, connected 2C
										PQ	Inserted 1C, isolated 1C, test 1C, connected 1C
								AM	ON/OFF button cover	P8	Inserted 2C, isolated 2C, test 2C, connected 2C
								AA	Additional 1a1b auxiliary switch	PR	Inserted 1C, isolated 1C, test 3C, connected 3C
								AB	Key lock device (prevent ON)		
								B8	OCR MCR function	BC	Auto connection control terminal cover
								BR	OCR manual reset function	AE	Safe shutter lock
								BA	OCR manual reset & alarm switch 2a	AX	Arc shield
								BH	OCR auto reset + high capacity alarm switch 1a	AF	Fixing block
								B6	Spring charge switch		
								AG	Door flange		

- U-series accessories are only applicable for instantaneous type and only UVT coil can be installed. When you want to use delay type, you can purchase delay type of controller (UANS-) additionally and install externally.
- B0: Internal part for mechanical interlock should be purchased additionally, if you mark B0, only internally interlocking components are transported with assembly (refer to additional components).
- In case of TSC, AUX S/W becomes 4a4b. And using MCR function of B8 OCR, AUX S/W becomes 4a5b. When using both TCS and MCR function, AUX S/W becomes 3a4b.
- Purchasing with solely main body code (A/J/Fixed type), it cannot be arranged with cradle accessories. Cradle accessory arrangement is possible when purchased with cradle. You should purchase additionally when you want main body (UANS-) solely (refer to additional components).
- Position switch cannot be overlapped and can be attached only on the right side of cradle. Inquire us if you need another arrangement.
- Internal part for mechanical interlock (B0), mechanical operated cell switch (MC), fixing block(AF) are not compatible one another.
- BC: Auto connection control terminal cover is only available for the auto connection.
- AK: 'Short "b"' is only available for auto connection and attached on 51, 52. It can be attached by the number of "B" points, so additionally purchase if you want to attach more.
- AG: Additionally attached originally, but inserted on front cover when shipped.
- MR: AE, AG, AF, and AM are attached as standard option, so those accessories are not marked additionally.
- AA and BA(BH) cannot be attached at the same time.
- UVT and TC2 cannot be attached at the same time.

Ordering Codes

I DUS type I

■ Cradle part for draw-out type ACB

DUS		12		A		3		A		H		AE		
Type		Rated current		Frame size & pole arrangement		Pole		Control terminal connection		Terminal busbar arrangement		Accessories		
DUS		10	DUS06 - 10A(W)	A	1,600AF, 630 - 1,600A 3P: RST		3	3 Pole		A	Auto connection		AE	Safe shutter lock
		16	DUS12 - 16A(W)		1,600AF, 630 - 1,600A 4P: RSTN/NRST		4	4 Pole		J	Manual connection			
		20	DUS20B(X)	B	3,200AF, 2,000 - 3,200A 3P: RST					T	Upper side: Horizontal Lower side: Vertical			
		25	DUS25B(X)		3,200AF, 2,000 - 3,200A					L	Upper side: Vertical Lower side: Horizontal			
		32	DUS32B(X)		4P: RSTN/NRST					P ¹⁾	Front type or others			

※ AE: Safety shutter lock is supplied with safety shutter.

※ 1) P type of fixed terminal busbar arrangement should be ordered and attached (refer to the additional components).

Technical Data

| Internal resistance and power consumption |

AF	Rated current(A)	Fixed type		Draw-out type	
		Internal resistance(MΩ)	Power consumption (W/3Phase)	Internal resistance(MΩ)	Power consumption (W/3Phase)
A frame UAN/UAS06 - 16	630	20	24	40	48
	800	20	38	40	77
	1,000	20	60	40	120
	1,250	20	94	40	188
	1,600	20	154	40	307
A frame UAN20	630	15	18	30	36
	800	15	29	30	58
	1,000	15	45	30	90
	1,250	15	70	30	141
	1,600	15	115	30	230
	2,000	13	156	27	324
B frame UAN/UAS20 - 32	2,000	10	120	20	240
	2,500	10	188	20	375
	3,200	10	307	20	614
B frame UAN 40B	2,000	10	120	20	240
	2,500	10	188	20	375
	3,200	10	307	20	614
	4,000	8	384	11	528
C frame UAN 40 - 50C	4,000	8	384	11	528
	5,000	8	600	11	825
D frame UAN 40 - 63D	4,000	6	288	9	432
	5,000	6	450	9	675
	6,300	5	595	7	833

※ 1) Power consumption listed is maximum power consumption for each rated current, 50/60Hz, 3/4 pole.

2) This is inner resistance value per pole.

3) Power factor = 1.0

| Insulation distance |

■ Insulation distance from arc

ACB		A	B
Fixed type		120mm	50mm
Draw-out type	Without Arc shield	120mm	50mm
	With Arc shield	0mm	50mm

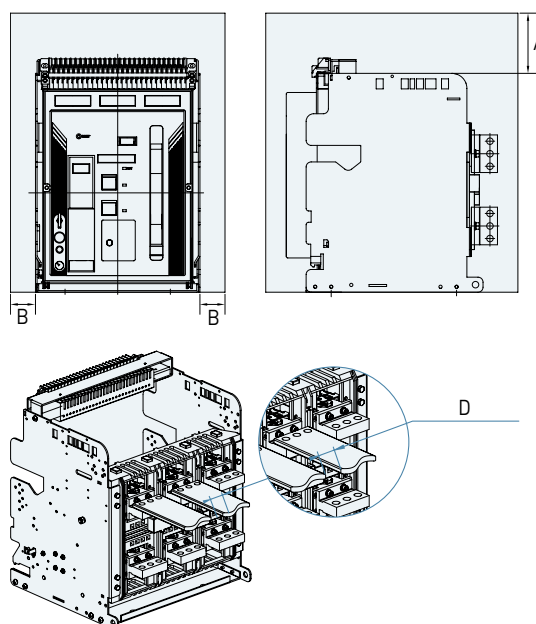

■ Minimum insulation distance at charging side

Insulating voltage	D
[V] ≤ 600V	8mm
600V < [V] ≤ 1,000V	14mm



Technical Data

| Rectification of rated current |

Frame	Rated current	Terminal busbar of ACB body	Applicable busbar size												
				Horizontal type					Vertical type						
				40°C	45°C	50°C	55°C	60°C	40°C	45°C	50°C	55°C	60°C		
A frame UAN/UAS06 - 16	200A	15t × 50mm × 1ea	5t × 50mm × 1ea	200A	200A	200A	200A	200A	200A	200A	200A	200A	200A	200A	
	400A			400A	400A	400A	400A	400A	400A	400A	400A	400A	400A	400A	
	630A		5t × 50mm × 2ea 10t × 60mm × 1ea	630A	630A	630A	630A	630A	630A	630A	630A	630A	630A	630A	630A
				800A	6t × 50mm × 2ea 10t × 60mm × 1ea	800A	800A	800A	800A	800A	800A	800A	800A	800A	800A
	1,000A		8t × 50mm × 2ea 6t × 75mm × 2ea			1,000A	1,000A	1,000A	1,000A	1,000A	1,000A	1,000A	1,000A	1,000A	1,000A
				1,250A	10t × 50mm × 2ea 6t × 75mm × 3ea	1,250A	1,250A	1,250A	1,250A	1,250A	1,250A	1,250A	1,250A	1,250A	1,250A
	1,600A		10t × 60mm × 2ea 8t × 60mm × 3ea			1,600A	1,600A	1,520A	1,480A	1,420A	1,600A	1,600A	1,580A	1,550A	1,550A
				A frame UAN20	2,000A	15t × 75mm × 1ea	8t × 75mm × 3ea 10t × 100mm × 2ea	-	-	-	-	-	2,000A	2,000A	1,940A
B frame UAN/UAS06 - 25	630A	20t × 75mm × 1ea	5t × 50mm × 2ea 10t × 60mm × 1ea	630A	630A	630A	630A	630A	630A	630A	630A	630A	630A	630A	
	800A			6t × 50mm × 2ea 10t × 60mm × 1ea	800A	800A	800A	800A	800A	800A	800A	800A	800A	800A	800A
			1,000A		8t × 50mm × 2ea 6t × 75mm × 2ea	1,000A	1,000A	1,000A	1,000A	1,000A	1,000A	1,000A	1,000A	1,000A	1,000A
	1,250A			8t × 60mm × 2ea 10t × 50mm × 2ea		1,250A	1,250A	1,250A	1,250A	1,250A	1,250A	1,250A	1,250A	1,250A	1,250A
			1,600A		6t × 75mm × 3ea 10t × 60mm × 2ea	1,600A	1,600A	1,600A	1,600A	1,600A	1,600A	1,600A	1,600A	1,600A	1,600A
	2,000A			8t × 60mm × 3ea 8t × 75mm × 3ea		2,000A	2,000A	2,000A	2,000A	2,000A	2,000A	2,000A	2,000A	2,000A	2,000A
			2,500A		10t × 100mm × 2ea 10t × 75mm × 3ea	-	-	-	-	-	2,000A	2,000A	2,000A	2,000A	2,000A
	3,200A			20t × 90mm × 1ea		10t × 100mm × 3ea 10t × 75mm × 4ea	-	-	-	-	-	3,200A	3,200A	3,120A	3,050A
B frame UAN40		4,000A Horizontal	15t × 100mm × 2ea		10t × 100mm × 4ea 10t × 125mm × 3ea	4,000A	4,000A	3,900A	3,800A	3,640A	-	-	-	-	-
	4,000A Vertical	15t × 125mm × 2ea	10t × 100mm × 4ea 10t × 125mm × 3ea	-	-	-	-	-	4,000A	4,000A	3,950A	3,800A	3,800A		
C frame UAN32 - 50	3,200A	20t × 125mm × 2ea	10t × 100mm × 3ea	3,200A	3,200A	3,100A	3,000A	2,900A	3,200A	3,200A	3,100A	3,000A	3,000A		
	4,000A		10t × 100mm × 4ea	4,000A	4,000A	3,920A	3,860A	3,800A	4,000A	4,000A	3,960A	3,900A	3,900A		
	5,000A		10t × 125mm × 4ea	5,000A	5,000A	4,900A	4,800A	4,700A	5,000A	5,000A	4,950A	4,900A	4,900A		
D frame UAN40 - 63	4,000A	20t × 125mm × 2ea	10t × 100mm × 4ea	4,000A	4,000A	4,000A	4,000A	4,000A	4,000A	4,000A	4,000A	4,000A	4,000A		
	5,000A		10t × 125mm × 4ea	5,000A	5,000A	4,900A	4,820A	4,750A	5,000A	5,000A	4,950A	4,870A	4,870A		
	6,300A		10t × 150mm × 4ea	6,300A	6,300A	6,170A	6,040A	5,900A	6,300A	6,300A	6,220A	6,160A	6,160A		

※ - Outer part of ACB's ambient temperature is applied for selecting ACB terminal busbar.
 - Terminal busbar is copper with no paintings.
 - The max. temperature for terminal busbar is 100°C

■ Altitude

U-Series ACB is designed for operation at altitudes under 2,000m. At altitudes higher than 2,000m, change the ratings upon service condition.

Item	Altitude	2,000m	3,000m	4,000m	5,000m
Withstand voltage[V]		3,500	3,150	2,500	2,100
Average insulating voltage[V]		1,000	900	700	600
Max. operation voltage [V]		690	590	520	460
Rectificated rated current [A]		1×In	0.99×In	0.96×In	0.94×In

| Derating table |

■ UAN

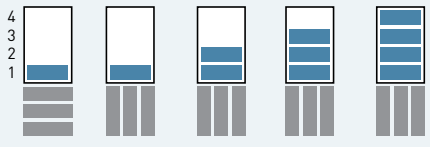
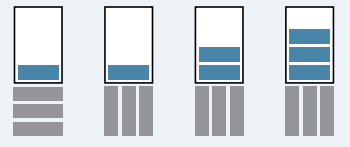
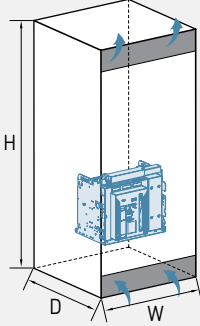
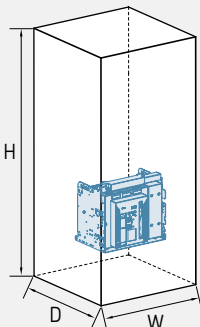
Switchboard composition connection type											
Model type	UAN 06 - 08A					UAN 10A					
Rated current ²⁾	-800A					1,000A					
Busbar dimensions (mm) ³⁾	2ea x 50 x 6					2ea x 50 x 8					
Ventilated switchboard (IP31) ⁴⁾ 	Ta ¹⁾ =35°C	4				800 ↓					
		3				800 ↓	800 ↓			1,000	
		2			800 ↓	800 ↓	800 ↓			1,000	1,000
	Ta=45°C	4				800 ↓					
		3				800 ↓	800 ↓				1,000
		2			800 ↓	800 ↓	800 ↓			1,000	1,000
	Ta=55°C	4				800 ↓					
		3				800 ↓	800 ↓				1,000
		2			800 ↓	800 ↓	800 ↓			1,000	1,000
	Non ventilated switchboard (IP52) ⁵⁾ 	Ta ¹⁾ =35°C	4				800 ↓				
			3				800 ↓	800 ↓			1,000
			2			800 ↓	800 ↓	800 ↓			1,000
Ta=45°C		4				800 ↓					
		3				800 ↓	800 ↓				1,000
		2			800 ↓	800 ↓	800 ↓			1,000	1,000
Ta=55°C		4				800 ↓					
		3				800 ↓	800 ↓				1,000
		2			800 ↓	800 ↓	800 ↓			1,000	1,000
Ta=55°C		1	800 ↓	800 ↓	800 ↓	800 ↓	800 ↓	1,000	1,000	1,000	1,000
		1	800 ↓	800 ↓	800 ↓	800 ↓	800 ↓	1,000	1,000	1,000	1,000
		1	800 ↓	800 ↓	800 ↓	800 ↓	800 ↓	1,000	1,000	1,000	1,000
Panel dimensions (mm): W x H x D		800 x 2,300 x 900									
Area of outlet vents (IP31)		350cm ²									
Area of inlet vents (IP31)		350cm ²									

※ 1) Ta refers to atmospheric temperature outside of panel (IEC 60439-1).

2) Rated current observes temperature condition on test according to IEC 60947-1,2. When installed inside the panel, derating of additional current and using indicated busbar dimension is required.

3) Busbar dimension is manufacturer's recommendation. Smaller busbar requires additional derating.

4) Ventilation should be designed to drop the temperature of switchboard inside the panel.

5) For non-ventilated switchboard, additional forced ventilation should be added to drop the temperature inside the panel.

Technical Data

| Derating table |

■ UAN

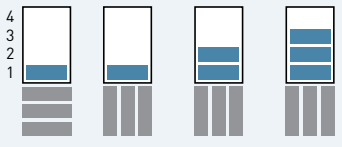
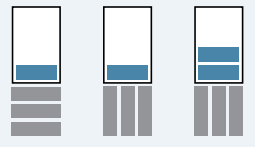
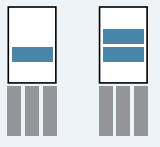
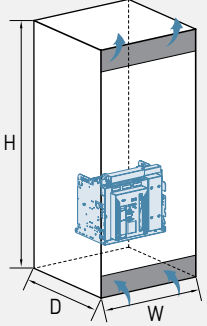
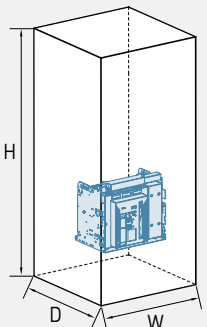
Switchboard composition connection type											
Model type	UAN 12A				UAN 16A			UAN 20A			
Rated current ²⁾	1,250A				1,600A			2,000A			
Busbar dimensions (mm) ³⁾	2ea x 75 x 8				3ea x 75 x 8			2ea x 100 x 10			
Ventilated switchboard (IP31)⁴⁾ 	Ta ¹⁾ =35°C	4									
		3				1,250				2,000	
		2			1,250	1,250			1,600	2,000	2,000
		1	1,250	1,250	1,250	1,250	1,600	1,600	1,600		
	Ta=45°C	4									
		3				1,250					1,900
		2			1,250	1,250			1,600	2,000	2,000
		1	1,250	1,250	1,250	1,250	1,600	1,600	1,600		
	Ta=55°C	4									
		3				1,250					1,800
		2			1,250	1,250			1,470	1,900	1,900
		1	1,250	1,250	1,250	1,250	1,520	1,600	1,600		
Non ventilated switchboard (IP52)⁵⁾ 	Ta ¹⁾ =35°C	4									
		3				1,250					1,750
		2			1,250	1,250			1,600	1,850	1,850
		1	1,250	1,250	1,250	1,250	1,600	1,600	1,600		
	Ta=45°C	4									
		3				1,250					1,650
		2			1,250	1,250			1,500	1,750	1,750
		1	1,250	1,250	1,250	1,250	1,500	1,600	1,600		
	Ta=55°C	4									
		3				1,250					1,550
		2			1,250	1,250			1,400	1,650	1,650
		1	1,250	1,250	1,250	1,250	1,400	1,520	1,520		
Panel dimensions (mm): W x H x D		800 x 2,300 x 900									
Area of outlet vents (IP31)		350cm ²									
Area of inlet vents (IP31)		350cm ²									





※ 1) Ta refers to atmospheric temperature outside of panel (IEC 60439-1).

2) Rated current observes temperature condition on test according to IEC 60947-1,2. When installed inside the panel, derating of additional current and using indicated busbar dimension is required.

3) Busbar dimension is manufacturer's recommendation. Smaller busbar requires additional derating.

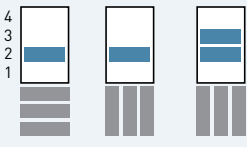
4) Ventilation should be designed to drop the temperature of switchboard inside the panel.

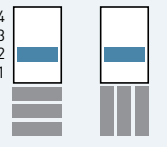
5) For non-ventilated switchboard, additional forced ventilation should be added to drop the temperature inside the panel.

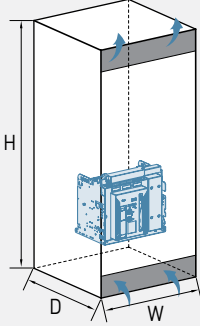
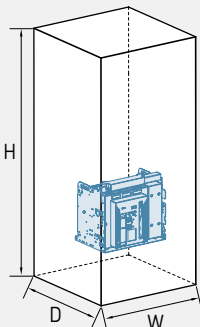
Switchboard composition connection type											
Model type	UAN 06-20B			UAN 25b		UAN 32b		UAN 40B			
Rated current ²⁾	2,000A			2,500A		3,200A		4,000A			
Busbar dimensions (mm) ³⁾	2ea x 100 x 10			3ea x 100 x 10		3ea x 125 x 10		4ea x 125 x 10			
Ventilated switchboard (IP31)⁴⁾ 	Ta ¹⁾ =35°C	4									
		3			2,000 ↓						
		2	2,000 ↓	2,000 ↓	2,000 ↓	2,375	2,500	3,040	3,200	3,320	3,700
		1									
	Ta=45°C	4									
		3			2,000 ↓						
		2	2,000 ↓	2,000 ↓	2,000 ↓	2,250	2,380	2,880	3,100	3,160	3,500
		1									
	Ta=55°C	4									
		3			2,000 ↓						
		2	2,000 ↓	2,000 ↓	2,000 ↓	2,100	2,250	2,690	2,900	2,960	3,280
		1									
Non ventilated switchboard (IP52)⁵⁾ 	Ta ¹⁾ =35°C	4									
		3			2,000 ↓						
		2	2,000 ↓	2,000 ↓	2,000 ↓	2,125	2,275	2,650	2,850	3,040	3,320
		1									
	Ta=45°C	4									
		3			1,900 ↓						
		2	1,960 ↓	1,960 ↓	1,960 ↓	2,000	2,150	2,550	2,700	2,880	3,120
		1									
	Ta=55°C	4									
		3			1,780 ↓						
		2	1,800 ↓	1,920 ↓	1,920 ↓	1,900	2,020	2,370	2,530	2,720	2,960
		1									
Panel dimensions (mm): W x H x D		800 x 2,300 x 900									
Area of outlet vents (IP31)		350cm ²									
Area of inlet vents (IP31)		350cm ²									

Technical Data

| Derating table |

■ UAN

Switchboard composition connection type													
Model type	UAN C40		UAN 50C		UAN 40D		UAN 50D		UAN 63D				
Rated current ²⁾	4,000A		5,000A		4,000A		5,000A		6,300A				
Busbar dimensions (mm) ³⁾	4ea x 125 x 10		5ea x 140 x 10		4ea x 125 x 10		5ea x 140 x 10		5ea x 160 x 10				
Ventilated switchboard (IP31) ⁴⁾ 	Ta ¹⁾ =35°C	4											
		3											
		2	3,900	4,000	4,550	4,850	4,000	4,000	4,700	5,000	5,550	5,850	
	Ta=45°C	4											
		3											
		2	3,850	3,900	4,350	4,650	4,000	4,000	4,450	4,850	5,380	5,670	
	Ta=55°C	4											
		3											
		2	3,800	3,850	4,100	4,400	4,000	4,000	4,200	4,600	5,080	5,350	
	Non ventilated switchboard (IP52) ⁵⁾ 	Ta ¹⁾ =35°C	4										
			3										
			2	3,800	3,900	4,200	4,500	4,000	4,000	4,350	4,650	5,050	5,290
Ta=45°C		4											
		3											
		2	3,650	3,800	3,950	4,250	4,000	4,000	4,100	4,400	4,780	5,040	
Ta=55°C		4											
		3											
		2	3,550	3,650	3,750	4,050	3,840	3,950	3,850	4,150	4,490	4,730	
Panel dimensions (mm): W x H x D		1,000 x 2,300 x 900				1,400 x 2,300 x 1,500							
Area of outlet vents (IP31)		500cm ²				500cm ²							
Area of inlet vents (IP31)		500cm ²				500cm ²							

※ 1) Ta refers to atmospheric temperature outside of panel (IEC 60439-1).

2) Rated current observes temperature condition on test according to IEC 60947-1,2. When installed inside the panel, derating of additional current and using indicated busbar dimension is required.

3) Busbar dimension is manufacturer's recommendation. Smaller busbar requires additional derating.

4) Ventilation should be designed to drop the temperature of switchboard inside the panel.

5) For non-ventilated switchboard, additional forced ventilation should be added to drop the temperature inside the panel.

| Derating table |

■ UAS

Switchboard composition connection type																		
Model type	UAS 06 - 08A					UAS 10A				UAS 12A								
Rated current ²⁾	-800A					1,000A				1,250A								
Busbar dimensions (mm) ³⁾	2ea x 50 x 6					2ea x 50 x 8				2ea x 75 x 8								
Ventilated switchboard (IP31) ⁴⁾ 	Ta ¹⁾ =35°C	4				800 ↓												
		3				800 ↓	800 ↓				1,000					1,250		
		2			800 ↓	800 ↓	800 ↓				1,000	1,000			1,250	1,250		
	Ta=45°C	1	800 ↓	800 ↓	800 ↓	800 ↓	800 ↓	1,000	1,000	1,000	1,000	1,250	1,250	1,250	1,250			
		4					800 ↓											
		3					800 ↓	800 ↓				1,000					1,250	
	Ta=55°C	2			800 ↓	800 ↓	800 ↓				1,000	1,000			1,200	1,150		
		1	800 ↓	800 ↓	800 ↓	800 ↓	800 ↓	1,000	1,000	1,000	1,000	1,250	1,250	1,250	1,250			
		4					800 ↓											
	Non ventilated switchboard (IP52) ⁵⁾ 	Ta ¹⁾ =35°C	4				800 ↓											
			3				800 ↓	800 ↓				1,000					1,050	
			2			800 ↓	800 ↓	800 ↓				1,000	1,000			1,200	1,150	
Ta=45°C		1	800 ↓	800 ↓	800 ↓	800 ↓	800 ↓	1,000	1,000	1,000	1,000	1,250	1,250	1,250	1,250			
		4					800 ↓											
		3					800 ↓	800 ↓				900					1,000	
Ta=55°C		2			800 ↓	800 ↓	800 ↓				975	950			1,100	1,050		
		1	800 ↓	800 ↓	800 ↓	800 ↓	800 ↓	1,000	1,000	1,000	1,000	1,250	1,250	1,150	1,150			
		4					800 ↓											
Ta=55°C		3					800 ↓	800 ↓				850					975	
		2			800 ↓	800 ↓	800 ↓				950	900			1,050	1,000		
		1	800 ↓	800 ↓	800 ↓	800 ↓	800 ↓	1,000	1,000	975	950	1,250	1,250	1,150	1,050			
Panel dimensions (mm): W x H x D		800 x 2,300 x 900																
Area of outlet vents (IP31)		350cm ²																
Area of inlet vents (IP31)		350cm ²																

Technical Data

| Derating table |

■ UAS

Switchboard composition connection type												
Model type	UAS 16A		UAS 20B		UAS 25B		UAS 32B					
Rated current ²⁾	1,600A		2,000A		2,500A		3,200A					
Busbar dimensions (mm) ³⁾	3ea x 75 x 8		2ea x 100 x 10		3ea x 100 x 10		3ea x 25 x 10					
Ventilated switchboard (IP31)⁴⁾ 	Ta ¹⁾ =35°C	4										
		3						2,000				
		2			1,600	2,000	2,000	2,000	2,375	2,500	2,880	3,100
		1	1,600	1,600	1,600							
	Ta=45°C	4										
		3						1,900				
		2			1,520	1,900	2,000	2,000	2,250	2,380	2,690	2,900
		1	1,600	1,600	1,600							
	Ta=55°C	4										
		3						1,800				
		2			1,450	1,800	1,950	1,900	2,100	2,250	2,500	2,700
		1	1,520	1,600	1,520							
Non ventilated switchboard (IP52)⁵⁾ 	Ta ¹⁾ =35°C	4										
		3						1,750				
		2			1,520	1,750	1,850	1,850	2,125	2,275	2,550	2,700
		1	1,600	1,600	1,600							
	Ta=45°C	4										
		3						1,650				
		2			1,450	1,650	1,750	1,750	2,000	2,150	2,370	2,530
		1	1,520	1,600	1,520							
	Ta=55°C	4										
		3						1,550				
		2			1,370	1,550	1,650	1,650	1,900	2,020	2,200	2,370
		1	1,370	1,450	1,450							
Panel dimensions (mm): W x H x D		800 x 2,300 x 900			800 x 2,300 x 900							
Area of outlet vents (IP31)		350cm ²			350cm ²							
Area of inlet vents (IP31)		350cm ²			350cm ²							

※ 1) Ta refers to atmospheric temperature outside of panel (IEC 60439-1).

2) Rated current observes temperature condition on test according to IEC 60947-1,2. When installed inside the panel, derating of additional current and using indicated busbar dimension is required.

3) Busbar dimension is manufacturer's recommendation. Smaller busbar requires additional derating.

4) Ventilation should be designed to drop the temperature of switchboard inside the panel.

5) For non-ventilated switchboard, additional forced ventilation should be added to drop the temperature inside the panel.

Discrimination table

• Breaking capacity: at AC380/415V

Downstream ↓	Upstream →		ACB													
	Recognition category	Model	Rated current (A)	Breaking capacity [Icu] (kA r.m.s)	UAN/UAS A frame					UAN/UAS B frame				UAN C frame		
					630	800	1,000	1,200	1,250	1,600	2,000	2,500	3,200	4,000	4,000	5,000
MCB	HiBD63-NS B, C curve	1	4.5	T	T	T	T	T	T	T	T	T	T	T	T	T
		2	4.5	T	T	T	T	T	T	T	T	T	T	T	T	T
		5	4.5	T	T	T	T	T	T	T	T	T	T	T	T	T
		6	4.5	T	T	T	T	T	T	T	T	T	T	T	T	T
		10	4.5	T	T	T	T	T	T	T	T	T	T	T	T	T
		16	4.5	T	T	T	T	T	T	T	T	T	T	T	T	T
		20	4.5	T	T	T	T	T	T	T	T	T	T	T	T	T
		25	4.5	T	T	T	T	T	T	T	T	T	T	T	T	T
		32	4.5	T	T	T	T	T	T	T	T	T	T	T	T	T
		40	4.5	T	T	T	T	T	T	T	T	T	T	T	T	T
	HiBD63-N B, C, D curve	1	6	T	T	T	T	T	T	T	T	T	T	T	T	T
		2	6	T	T	T	T	T	T	T	T	T	T	T	T	T
		3	6	T	T	T	T	T	T	T	T	T	T	T	T	T
		4	6	T	T	T	T	T	T	T	T	T	T	T	T	T
		5	6	T	T	T	T	T	T	T	T	T	T	T	T	T
		6	6	T	T	T	T	T	T	T	T	T	T	T	T	T
		10	6	T	T	T	T	T	T	T	T	T	T	T	T	T
		13	6	T	T	T	T	T	T	T	T	T	T	T	T	T
		15	6	T	T	T	T	T	T	T	T	T	T	T	T	T
		16	6	T	T	T	T	T	T	T	T	T	T	T	T	T
		20	6	T	T	T	T	T	T	T	T	T	T	T	T	T
		25	6	T	T	T	T	T	T	T	T	T	T	T	T	T
		32	6	T	T	T	T	T	T	T	T	T	T	T	T	T
		40	6	T	T	T	T	T	T	T	T	T	T	T	T	T
	50	6	T	T	T	T	T	T	T	T	T	T	T	T	T	
	63	6	T	T	T	T	T	T	T	T	T	T	T	T	T	
	HiBD63h B, C, D curve	1	10	T	T	T	T	T	T	T	T	T	T	T	T	T
		2	10	T	T	T	T	T	T	T	T	T	T	T	T	T
		3	10	T	T	T	T	T	T	T	T	T	T	T	T	T
		4	10	T	T	T	T	T	T	T	T	T	T	T	T	T
5		10	T	T	T	T	T	T	T	T	T	T	T	T	T	
6		10	T	T	T	T	T	T	T	T	T	T	T	T	T	
10		10	T	T	T	T	T	T	T	T	T	T	T	T	T	
13		10	T	T	T	T	T	T	T	T	T	T	T	T	T	
15		10	T	T	T	T	T	T	T	T	T	T	T	T	T	
16		10	T	T	T	T	T	T	T	T	T	T	T	T	T	
20	10	T	T	T	T	T	T	T	T	T	T	T	T	T		

※ T Can be blocked all sectors. - Can not be blocked.

Technical Data

• Breaking capacity: at AC380/415V

Downstream ↓	Upstream →		ACB													
	Recognition category	Model	Rated current (A)	Breaking capacity [Icu] (kA r.m.s)	UAN/UAS A frame						UAN/UAS B frame				UAN C frame	
					630	800	1,000	1,200	1,250	1,600	2,000	2,500	3,200	4,000	4,000	5,000
MCB	HiBD63h B, C, D curve	25	10	T	T	T	T	T	T	T	T	T	T	T	T	T
		32	10	T	T	T	T	T	T	T	T	T	T	T	T	T
		40	10	T	T	T	T	T	T	T	T	T	T	T	T	T
		50	10	T	T	T	T	T	T	T	T	T	T	T	T	T
		63	10	T	T	T	T	T	T	T	T	T	T	T	T	T
	HiBD125 B, C, D curve	63	10	T	T	T	T	T	T	T	T	T	T	T	T	T
		80	10	T	T	T	T	T	T	T	T	T	T	T	T	T
		100	10	T	T	T	T	T	T	T	T	T	T	T	T	T
		125	10	T	T	T	T	T	T	T	T	T	T	T	T	T
		MCCB	UAB100 C, R, S	5	30	T	T	T	T	T	T	T	T	T	T	T
10	30			T	T	T	T	T	T	T	T	T	T	T	T	T
15	30			T	T	T	T	T	T	T	T	T	T	T	T	T
20	30			T	T	T	T	T	T	T	T	T	T	T	T	T
30	30			T	T	T	T	T	T	T	T	T	T	T	T	T
40	30			T	T	T	T	T	T	T	T	T	T	T	T	T
50	30			T	T	T	T	T	T	T	T	T	T	T	T	T
60	30			T	T	T	T	T	T	T	T	T	T	T	T	T
75	30			T	T	T	T	T	T	T	T	T	T	T	T	T
100	30			T	T	T	T	T	T	T	T	T	T	T	T	T
UCB100 R, S, H, L	15		50	T	T	T	T	T	T	T	T	T	T	T	T	T
	20		50	T	T	T	T	T	T	T	T	T	T	T	T	T
	30		50	T	T	T	T	T	T	T	T	T	T	T	T	T
	40		50	T	T	T	T	T	T	T	T	T	T	T	T	T
	50		50	T	T	T	T	T	T	T	T	T	T	T	T	T
	60		50	T	T	T	T	T	T	T	T	T	T	T	T	T
	75		50	T	T	T	T	T	T	T	T	T	T	T	T	T
	100		50	T	T	T	T	T	T	T	T	T	T	T	T	T
UCB250 R, S, N, H, L	100		50	T	T	T	T	T	T	T	T	T	T	T	T	T
	125		50	T	T	T	T	T	T	T	T	T	T	T	T	T
	150		50	T	T	T	T	T	T	T	T	T	T	T	T	T
	175		50	T	T	T	T	T	T	T	T	T	T	T	T	T
	200		50	T	T	T	T	T	T	T	T	T	T	T	T	T
	225		50	T	T	T	T	T	T	T	T	T	T	T	T	T
	250		50	T	T	T	T	T	T	T	T	T	T	T	T	T

※ T Can be blocked all sectors. - Can not be blocked.

| Discrimination table |

• Breaking capacity: at AC380/415V

Downstream ↓	Upstream →		ACB														
	Recognition category	Model	Rated current (A)	Breaking capacity [Icu] (kA r.m.s)	UAN/UAS A frame						UAN/UAS B frame				UAN C frame		
					630	800	1,000	1,200	1,250	1,600	2,000	2,500	3,200	4,000	4,000	5,000	
					85	85	85	85	85	85	100	100	100	100	100	100	
MCCB	UCB400 R, S, N, H, L	250	100	T	T	T	T	T	T	T	T	T	T	T	T	T	
		300	100	T	T	T	T	T	T	T	T	T	T	T	T	T	
		320	100	T	T	T	T	T	T	T	T	T	T	T	T	T	T
		350	100	T	T	T	T	T	T	T	T	T	T	T	T	T	T
		400	100	T	T	T	T	T	T	T	T	T	T	T	T	T	T
	UCB630 R, S, H, L	500	100	-	T	T	T	T	T	T	T	T	T	T	T	T	T
		630	100	-	T	T	T	T	T	T	T	T	T	T	T	T	T
	UCB800 R, S, H, L	700	100	-	-	T	T	T	T	T	T	T	T	T	T	T	T
		800	100	-	-	T	T	T	T	T	T	T	T	T	T	T	T
	UPB100 S, H, L, X	15	150	T	T	T	T	T	T	T	T	T	T	T	T	T	T
		20	150	T	T	T	T	T	T	T	T	T	T	T	T	T	T
		30	150	T	T	T	T	T	T	T	T	T	T	T	T	T	T
		40	150	T	T	T	T	T	T	T	T	T	T	T	T	T	T
		50	150	T	T	T	T	T	T	T	T	T	T	T	T	T	T
		63	150	T	T	T	T	T	T	T	T	T	T	T	T	T	T
		80	150	T	T	T	T	T	T	T	T	T	T	T	T	T	T
		100	150	T	T	T	T	T	T	T	T	T	T	T	T	T	T
		125	150	T	T	T	T	T	T	T	T	T	T	T	T	T	T
		125	150	T	T	T	T	T	T	T	T	T	T	T	T	T	T
	UPB250 R, S, N, H, L	150	150	T	T	T	T	T	T	T	T	T	T	T	T	T	T
		175	150	T	T	T	T	T	T	T	T	T	T	T	T	T	T
		200	150	T	T	T	T	T	T	T	T	T	T	T	T	T	T
		225	150	T	T	T	T	T	T	T	T	T	T	T	T	T	T
		250	150	T	T	T	T	T	T	T	T	T	T	T	T	T	T
		250	150	T	T	T	T	T	T	T	T	T	T	T	T	T	T
	UPB400 S, H, L, X	250	150	T	T	T	T	T	T	T	T	T	T	T	T	T	T
		300	150	T	T	T	T	T	T	T	T	T	T	T	T	T	T
		320	150	T	T	T	T	T	T	T	T	T	T	T	T	T	T
		350	150	T	T	T	T	T	T	T	T	T	T	T	T	T	T
		400	150	T	T	T	T	T	T	T	T	T	T	T	T	T	T
	UPB630 S, H, L, X	320	150	T	T	T	T	T	T	T	T	T	T	T	T	T	T
		350	150	T	T	T	T	T	T	T	T	T	T	T	T	T	T
400		150	T	T	T	T	T	T	T	T	T	T	T	T	T	T	
500		150	-	T	T	T	T	T	T	T	T	T	T	T	T	T	
630		150	-	T	T	T	T	T	T	T	T	T	T	T	T	T	

※ T Can be blocked all sectors. - Can not be blocked.

Operating Conditions

| Ambient temperature |

- Operating condition: -5 °C to 40 °C is recommended.
- The average temperature for 24 hours should be within 35 °C.
- Reduce the continuous conducting current when the temperature is over 45 °C (Refer to derating table, 98 page).

| Relative humidity |

- Relative humidity should be under 85 %.

| Load (I/In) |

Load	Using	Effect	Installation
I/In ≤ 80 %	24/24 Hours	-	Normal condition (Recommend)
80 < I/In ≤ 90 %	24/24 Hours	-	Periodic inspection
I/In = 100 %	24/24 Hours	Plastic insulator color changed	Exhaust added

| Storage conditions |

- Device without its control unit: -25 °C to 85 °C
- Device with control unit: -15 °C to 70 °C
- The product with charging motor should be stored in open position.

| Atmospheric conditions |

- Do not apply under corrosive or ammonia gas circumstances (H2S, SO2, NH3).
- Use in clean air condition.

| Altitude |

Item	Altitude		
	2,000 m (6,600 feet)	2,600 m (8,500 feet)	3,900m (13,000 feet)
Isolation voltage [V]	1,000	950	800
Operating voltage [V]	690	655.5	552
Allowed current [A]	1 x In	0.99 x In	0.96 x In

| Protection degree provided by enclosures (IP code)|

- Standard: IP30
- With dust cover: IP52

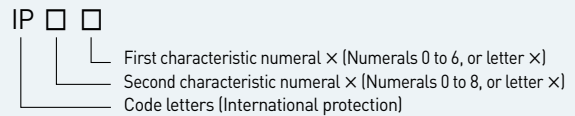

	Degree of protection	
	First characteristic numeral	Second characteristic numeral
0	No protection (OPEN)	No protection (OPEN)
1	Protected against solid foreign objects of 50 mm ø and greater	Protected against vertically falling water drops
2	Protected against solid foreign objects of 12.5 mm ø and greater	Protected against vertically falling water drops when enclosure tilted up to 15°
3	Protected against solid foreign objects of 2.5 mm ø and greater	Protected against spraying water (at an angle up to 60°)
4	Protected against solid foreign objects of 1.0 mm ø and greater	Protected against spraying water (Splash proof)
5	Dust-protected (Ingress of dust is not totally prevented)	Protected against spraying jets (Hose proof)
6	Dust-tight (No ingress of dust)	Protected against powerful water jets (Deckwater proof)
7	-	Protected against the effects of temporary immersion in water (Under pressure and time)
8	-	Protected against the effects of continuous immersion in water (Submersible)

Installation conditions

- For the enhancement of the structural safety, please install the fixing block as the following drawing where the product damage is expected due to electrical fault.

(unit: mm)

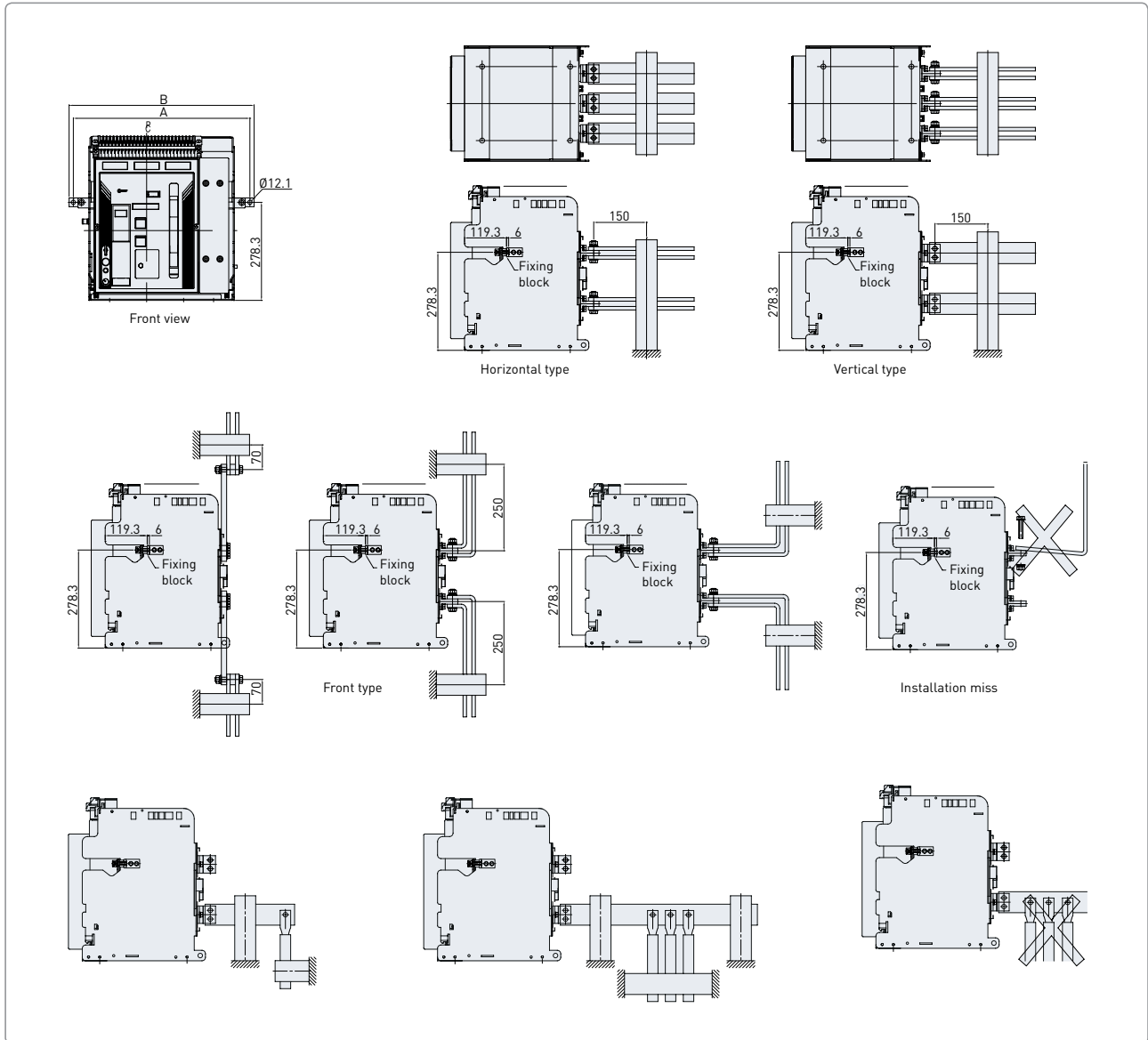

Model	A	B
UAS06 - 16 A 3P, UAN06 - 20 A 3P	416	440
UAS06 - 16 A 4P, UAN06 - 20 A 4P	501	525
UAS20 - 32 A 3P, UAN20 - 40 A 3P	487	511
UAS20 - 32 A 4P, UAN20 - 40 A 4P	602	626
UAN40 - 50 C 3P	712	736
UAN40 - 50 C 4P	906	982

Ordering Sheet

• To indicate your choice, check the applicable boxes and enter the appropriate information corresponding to your choice.

ACB body	Type of ACB	<input type="checkbox"/> UAN		<input type="checkbox"/> UAS ¹⁾									
	Frame size	AF											
		<input type="checkbox"/> A (630 - 2,000AF) ²⁾	<input type="checkbox"/> B (630 - 4,000AF) ³⁾	<input type="checkbox"/> C (3,200 - 5,000AF)	<input type="checkbox"/> D (4,000 - 6,300AF)								
	Phase type	<input type="checkbox"/> Standard type (R, S, T, N)		<input type="checkbox"/> Reverse phase type (N, R, S, T)									
	Number of poles	<input type="checkbox"/> 3 pole		<input type="checkbox"/> 4 pole									
	Type of equipment	<input type="checkbox"/> Draw-out type		<input type="checkbox"/> Fixed type									
	Terminal connection (Draw-out type)	<input type="checkbox"/> Manual connection		<input type="checkbox"/> Auto connection									
	Terminal busbar arrangement (Fixed type)	<input type="checkbox"/> Horizontal <input type="checkbox"/> Vertical <input type="checkbox"/> Horizontal/Vertical (Line/Load) <input type="checkbox"/> Vertical/Horizontal (Line/Load) <input type="checkbox"/> Front type or others ⁴⁾											
	Charging	<input type="checkbox"/> Manual closing											
		<input type="checkbox"/> Electrical closing											
		• Motor operating voltage		<input type="checkbox"/> AC/DC110V	<input type="checkbox"/> DC125V	<input type="checkbox"/> DC24V							
				<input type="checkbox"/> AC/DC220V	<input type="checkbox"/> AC380V ⁵⁾	<input type="checkbox"/> AC440V ⁵⁾							
	Closing voltage	<input type="checkbox"/> AC/DC110V	<input type="checkbox"/> DC125V	<input type="checkbox"/> AC/DC220V	<input type="checkbox"/> DC24V	<input type="checkbox"/> DC48V							
					<input type="checkbox"/> AC380V	<input type="checkbox"/> AC440V							
	Trip voltage	<input type="checkbox"/> AC/DC110V	<input type="checkbox"/> DC125V	<input type="checkbox"/> AC/DC220V	<input type="checkbox"/> DC24V	<input type="checkbox"/> DC48V							
				<input type="checkbox"/> AC380V	<input type="checkbox"/> AC440V								
Protection trip relay	<input type="checkbox"/> NO												
	<input type="checkbox"/> YES												
	50Hz	60Hz	Model	LCD/LED	Application	Ground fault detection ⁶⁾	Signal	NCT	ELT	Comm ⁷⁾	MCR	Memory	Adaptor
	<input type="checkbox"/> 33	<input type="checkbox"/> 43	UPR-1L-GS	—	General feeder	<input type="checkbox"/> O	Integrated instantaneous 1a	<input type="checkbox"/> O	—	—	<input type="checkbox"/> O	—	—
	<input type="checkbox"/> 35	<input type="checkbox"/> 45	UPR-2L-GS	<input type="checkbox"/> O	General feeder	<input type="checkbox"/> O	Individual continuous 4a	<input type="checkbox"/> O	—	—	<input type="checkbox"/> O	<input type="checkbox"/> O	<input type="checkbox"/> O
	<input type="checkbox"/> 36	<input type="checkbox"/> 46	UPR-1D-GT	<input type="checkbox"/> O	General feeder	<input type="checkbox"/> O	Individual continuous 4a	<input type="checkbox"/> O	<input type="checkbox"/> O	<input type="checkbox"/> O	<input type="checkbox"/> O	<input type="checkbox"/> O	<input type="checkbox"/> O
	<input type="checkbox"/> 37	<input type="checkbox"/> 47	UPR-2L-GM	<input type="checkbox"/> O	General feeder	<input type="checkbox"/> O	Integrated continuous 3a ⁸⁾	<input type="checkbox"/> O	—	—	<input type="checkbox"/> O	<input type="checkbox"/> O	<input type="checkbox"/> O
	<input type="checkbox"/> 38	<input type="checkbox"/> 48	UPR-1S-AL	—	Generator	—	Integrated instantaneous 1a	—	—	—	<input type="checkbox"/> O	—	—
	<input type="checkbox"/> 39	<input type="checkbox"/> 49	UPR-2S-AS	<input type="checkbox"/> O	Generator	—	Individual continuous 3a ⁹⁾	—	—	—	<input type="checkbox"/> O	<input type="checkbox"/> O	<input type="checkbox"/> O
Current transformer	<input type="checkbox"/> 80A <input type="checkbox"/> 160A ····												
Accessory	• UVT coil (Instantaneous type)		<input type="checkbox"/> AC/DC110V	<input type="checkbox"/> DC125V	<input type="checkbox"/> DC24V	<input type="checkbox"/> DC48V							
			<input type="checkbox"/> AC/DC220V	<input type="checkbox"/> AC380V	<input type="checkbox"/> AC440V								
	• Double trip coil ¹⁰⁾		<input type="checkbox"/> AC/DC110V	<input type="checkbox"/> DC125V	<input type="checkbox"/> DC24V	<input type="checkbox"/> DC48V							
			<input type="checkbox"/> AC/DC220V	<input type="checkbox"/> AC380V	<input type="checkbox"/> AC440V								
	• Trip supervision coil		<input type="checkbox"/> AC/DC110V	<input type="checkbox"/> DC125V	<input type="checkbox"/> DC24V	<input type="checkbox"/> DC48V							
			<input type="checkbox"/> AC/DC220V	<input type="checkbox"/> AC380V	<input type="checkbox"/> AC440V								
	• Auxiliary switch		<input type="checkbox"/> 3a3b (Standard for UAS)	<input type="checkbox"/> 5a5b (Standard for UAN)	<input type="checkbox"/> 6a6b (Maximum)								
	• OCR MCR wire		<input type="checkbox"/> Complete parts of ACB/Cradle		<input type="checkbox"/> Spare part								
	• OCR & Alarm switch reset button		<input type="checkbox"/> BR: OCR (Only for manual reset button)		<input type="checkbox"/> BA: OCR manual reset+Alarm switch								
			<input type="checkbox"/> BM: OCR (Auto reset)+Alarm switch										
	• Counter (Standard)												
	• Fixing block ¹¹⁾		<input type="checkbox"/> Complete parts of ACB/Cradle		<input type="checkbox"/> Spare part								
	• Wrong insertion preventer ¹¹⁾		<input type="checkbox"/> Complete parts of ACB/Cradle		<input type="checkbox"/> Spare part								
• Key lock device		<input type="checkbox"/> Complete parts of ACB/Cradle		<input type="checkbox"/> Spare part									
• ON/OFF button lock		<input type="checkbox"/> Complete parts of ACB/Cradle		<input type="checkbox"/> Spare part									
• Mechanical interlock ¹²⁾		<input type="checkbox"/> Complete parts of ACB/Cradle		<input type="checkbox"/> Spare part									
• Spring charge switch		<input type="checkbox"/> Complete parts of ACB/Cradle		<input type="checkbox"/> Spare part									

Cradle	Control terminal	<input type="checkbox"/> Manual connection			
	Terminal busbar arrangement	<input type="checkbox"/> Horizontal <input type="checkbox"/> Vertical <input type="checkbox"/> Horizontal/Vertical (Line/Load) <input type="checkbox"/> Vertical/Horizontal (Line/Load) <input type="checkbox"/> Front type or others ⁴⁾			
	Accessory	• Safety shutter lock ¹³⁾	<input type="checkbox"/> Complete parts of ACB/Cradle	<input type="checkbox"/> Spare part	
		• Fixing block ¹¹⁾	<input type="checkbox"/> Complete parts of ACB/Cradle	<input type="checkbox"/> Spare part	
		• Wrong insertion preventor ¹¹⁾	<input type="checkbox"/> Complete parts of ACB/Cradle	<input type="checkbox"/> Spare part	
		• Arc shield	<input type="checkbox"/> Complete parts of ACB/Cradle	<input type="checkbox"/> Spare part	
		• Short "b" contact ¹⁴⁾	<input type="checkbox"/> Complete parts of ACB/Cradle	<input type="checkbox"/> Spare part	
• Control terminal protection cover ¹⁵⁾		<input type="checkbox"/> Complete parts of ACB/Cradle	<input type="checkbox"/> Spare part		
	• Mechanical operated cell switch	<input type="checkbox"/> Complete parts of ACB/Cradle	<input type="checkbox"/> Spare part		
ACB accessory	Purchase separately	• Phase insulation barrier			
		• UVT time delay controller ¹⁶⁾	<input type="checkbox"/> AC/DC110V <input type="checkbox"/> DC125V <input type="checkbox"/> DC24V <input type="checkbox"/> DC48V	<input type="checkbox"/> AC/DC220V <input type="checkbox"/> AC380V <input type="checkbox"/> AC440V	
		• Position switch ¹⁶⁾	<input type="checkbox"/> AQ=Test1C, Connected1C <input type="checkbox"/> AR=Connected2C <input type="checkbox"/> AS=Test2C	<input type="checkbox"/> AT=Inserted1C, Isolated1C <input type="checkbox"/> AU=Inserted2C <input type="checkbox"/> AV=Isolated2C	
			<input type="checkbox"/> PQ=Inserted1C, Isolated1C, Test1C, Connected1C <input type="checkbox"/> P4=Test2C, Connected2C <input type="checkbox"/> P8=Inserted2C, Isolated2C, Test2C, Connected2C		
		• Mechanical interlock	<input type="checkbox"/> Wire type (2 terminals)	<input type="checkbox"/> Wire type (3 terminals)	
		• Condenser trip device	<input type="checkbox"/> AC110V	<input type="checkbox"/> AC220V	
		• Test jumper		• OCR portable checker	
		• Draw-in/out handle	<input type="checkbox"/> Standard type	<input type="checkbox"/> Long type	<input type="checkbox"/> Universal type
		• ATS Controller		• Automatic transfer switch & controller	
		• Lifting lug		• Dummy ACB	
		• Door flange		• Dust cover	
		• ZCT (Consultation)		• NCT (Consultation)	
				• Remote operation & temperature detection module	

※ 1) In case of UAS, A frame size is in the range of 630 - 1,600AF and B frame size is in the range of 2,000 - 3,200AF.

2) In case of UAN 20A, only vertical type is available.

3) In case of UAN, B frame size of 630 - 1,600AF is possible.

4) Front type/User installation need to be ordered separately and attached by the customer. 630 - 1,600AF is available for A frame and 2,000 - 3,200AF is available for B frame.

5) Motor of AC380/440V is available from June. 2013.

6) Standard function for general feeder: Ground fault detection.

7) Communication function is not available under no control voltage.

8) LTD/STD/INST/ELT [except. PTA]

9) LTD/STD/INST/PTA [except. GFT]

10) In case of ordering UVT, double trip coil is not available.

11) In case of ordering fixing block and wrong insertion preventer, mark on both ACB and cradle ordering sheet.

12) MI is separate purchasing item, only assembled parts interacting inside of the body are delivered.

13) In case of ordering safety shutter-attachment type, shutter lock is automatically implemented.

14) Fixing block and wrong insertion preventer have to be marked on both the body and cradle orders.

15) Control terminal protection cover is only available for automatic connection type.

16) UVT controller and position switch can be offered as mounted.



www.hyundai-elec.com



ELECTRO ELECTRIC SYSTEMS

Head Office	1000, Bangeojinsunhwan-doro, Dong-gu, Ulsan, Korea Tel: 82-52-202-8101~7 Fax: 82-52-202-8100
Seoul (Sales & Marketing)	75, Yulgok-ro, Jongno-gu, Seoul, Korea Tel: 82-2-746-8519, 7492, 7620 Fax: 82-2-746-7441
Atlanta	6100 Atlantic Boulevard, Norcross, GA 30071, USA Tel: 1-678-823-7839 Fax: 1-678-823-7553
London	2nd Floor, The Triangle, 5-17 Hammersmith Grove London, W6 0LG, UK Tel: 44-20-8741-0501 Fax: 44-20-8741-5620
Moscow	World Trade Center, Ent. 3# 703, Krasnopresnenskaya Nab. 12, Moscow, 123610, Russia Tel: 7-495-258-1381 Fax: 7-495-258-1382
Tokyo	8th Floor, North Tower Yurakucho Denki Bldg., 1-7-1 Yuraku-cho, Chiyoda-ku, Tokyo 100-0006, Japan Tel: 81-3-3211-4792 Fax: 81-3-3216-0728
Osaka	I-Room 5th Floor Nagahori Plaza Bldg. 2-4-8 Minami Senba, Chuo-ku, Osaka, 542-0081, Japan Tel: 81-6-6261-5766~7 Fax: 81-6-6261-5818
Riyadh	Office No. 230, 2nd Floor, 4th Akariya Plaza, Olaya Street, PO Box 8072, Riyadh 11485, Saudi Arabia Tel: 966-11-464-4696 Fax: 966-11-462-2352
Dubai	Unit 205, Building 4, Emaar Square, Sheikh Zayed Road, Pobox 252458, Dubai, UAE Tel: 971-4-425-7995 Fax: 971-4-425-7996
Sofia	1271 Sofia 41, Rojen Blvd., Bulgaria Tel: 359-2-803-3200, 3220 Fax: 359-2-803-3203
Alabama	215 Folmar Parkway, Montgomery, AL 36105, USA Tel: 1-334-481-2000 Fax: 1-334-481-2098
Ohio	330 East First Street, Mansfield, OH 44902 USA Tel: 1-724-759-7445 Fax: 1-419-522-9386
Vladivostok	15 str. Potemkina, Artem, Primorskiy Krai, 692760, Russia Tel: 7-423-201-0110 Fax: 7-423-201-0110
Yangzhong	No.9 Xiandai Road, Xinba Scientific and Technologic Zone, Yangzhong, Jiangsu, P.R.C. Zip: 212212, China Tel: 86-511-8842-0666, 0212 Fax: 86-511-8842-0668, 0231